



THREE AVIATION MAGAZINES IN ONE!

# FLYING ACES

AUGUST 15¢



C.D.M.

LONDON UNDER AIR ATTACK

PHILIP STRANGE, PHINEAS AND KERRY KEEN STORIES  
THRILLING ARTICLES BY LEWIS, CAMERON AND OTHERS  
MODEL PLANS OF MARTIN DIVING BOMBER AND STRATOSPHERE SHIP

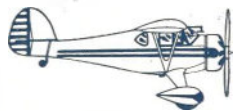

# AIRCRAFT



THE MOST AUTHENTIC LINE OF 1/4 INCH TO THE FOOT SOLID SCALE MODELS EVER OFFERED

## A PERFECT MODEL

of America's most beautiful Transport Plane, holder of many world's records. This kit is furnished in either the new projected color scheme as illustrated or in the regulation T. W. A metallic Silver. Please specify.

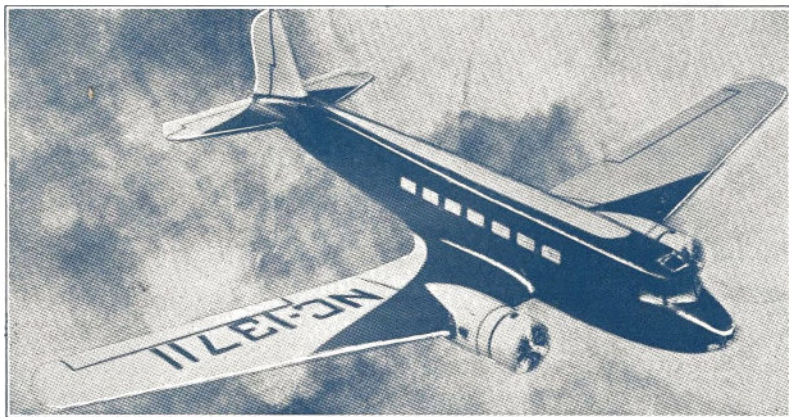

GIANT DOUGLAS TRANSPORT PRICE \$1.50

The kit to build the model of this modern giant contains: selected balsa parts cut to outline shape, turned hard wood cowls and wheels, two super detailed pilots, two three-bladed Hamilton propellers, liberal portions of colored lacquers or silver dope, wood filler, and fillet making material, full size detailed drawings and everything required to complete this perfect model.

This reduced side view sketch of our Curtiss Goshawk, taken from an AIRCRAFT plan, illustrates the perfect detailing that is characteristic of all AIRCRAFT drawings.

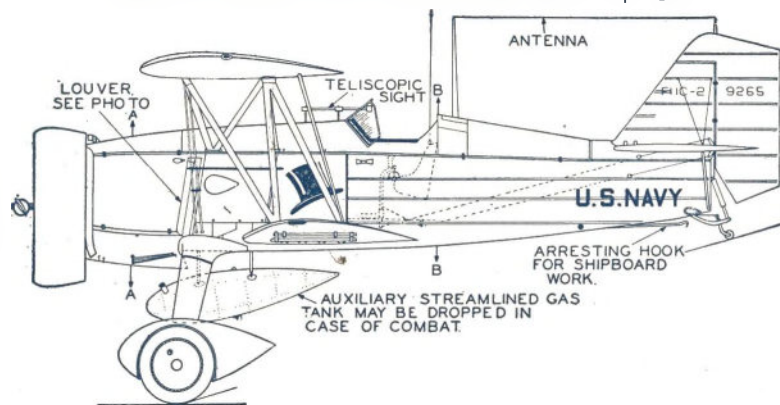

## MARTIN BOMBER

The most perfect miniature reproduction of this wonderful Plane ever produced, so real that it is hard to distinguish it from the original ship, so complete that there is nothing left to ask for. Dealers everywhere pronounce this the most perfect kit they have ever seen and the greatest value ever offered, it's a real massive contest winner. Complete kit \$1.25 postpaid.

## EVERY ONE A CONTEST WINNER

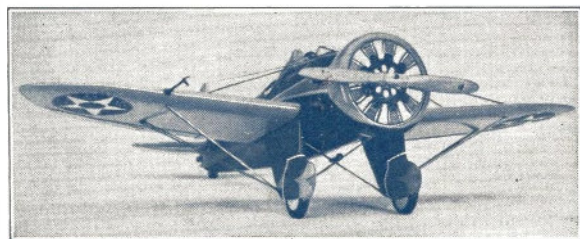

BOEING P26A



CURTISS HAWK P.6.E.

WE officially announce the opening of our new Chicago Store, where these beautiful solid models will be on exhibition. For your convenience we also carry a stock of the following products. Cleveland, G.H.Q., Hawk, Lindberg, Megow, Ott and M & M Air wheels.



SOPWITH CAMEL

**UNSOLICITED TESTIMONIAL**  
I am a commander in a flight squadron of the Junior Birdmen of America. We all voted that AIRCRAFT kits are the most reasonable and most complete kits to buy and we also voted to build and buy AIRCRAFT kits only.  
(Signed)  
ARTHUR DROGE, Woodhaven, N. Y.

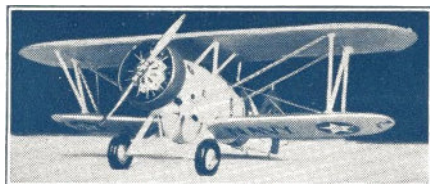

BOEING F4B4

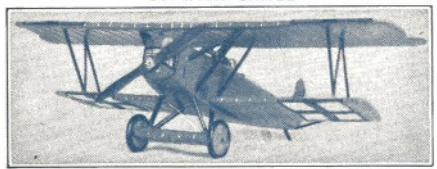

REDESIGNED FOKKER D-VII



NEW MONOCOUCHE

## DEALERS

PLEASE

WRITE

NOTE: All pictures on this page are photographs of actual models.

**AIRCRAFT**

WE CARRY IN STOCK THE FOLLOWING KITS  
Spad XIII      Nieuport XVII      Fokker Triplane  
Fokker D-VII      Sop. Camel      Curtiss Goshawk  
S.E.5      New Monocoupe      Albatross D5  
Waco Model "A"      Fokker D-VIII      Boeing P12E  
Boeing F4B4      Boeing P26A      Boeing F4B3  
DeH "Comet" 50 Cts.      Boeing P12F      Curtiss Hawk P6E

### EACH KIT CONTAINS

Liberal portions of colored lacquers and cement, finished pine wheels, colored insignias, rigging wires, most difficult parts cut to outline shape, detailed drawings, etc. The greatest value ever offered at any price.

All solid kits contain DIE CAST PROPELLERS, PILOTS and SUPER-DETAILED MACHINE GUNS when required.

EASILY ASSEMBLED. SIMPLIFIED CONSTRUCTION. WORLD FAMOUS PLANES.

CANADA, 10 cents EXTRA.

Add 10 cents to cover cost of exchange on personal checks.

**40 cents each, 3 for \$1.00**

Th's Does Not Include DeH "Comet", Martin or Douglas

**3502 NORTH CICERO AVENUE**

**CHICAGO**



# Get on AVIATION'S PAYROLL!

### Gives Credit to Training

"At present, I am employed with one of the largest builders of aircraft on Long Island. It was the knowledge I received through your course in Aviation that secured me this position."

Carl Schneider,  
4215 Graham Ave.,  
Astoria, New York.

## Let Me Show You How to

# EARN \$30 a Week and UP in AVIATION!

My up-to-date home-study Course gives you the ground work you need to *get and keep a real job* in this fascinating, fast-growing industry. Scores of my graduates, who didn't know a thing about Aviation a few months ago, are holding down fine jobs right now—in the air and on the ground. *Over forty different types of jobs to choose from*, once you have this necessary training. Get the facts about my practical training, free Employment Service and Money-Back Agreement NOW!

### I Teach You Quickly--at Home in Your Spare Time

You don't need to give up your present job—don't need to leave home, to get your training in Aviation. I've made it easy for you. I've put my own fifteen years of experience—backed by over 400,000 miles of flying—five years of instructing in the Navy—all into my thorough, quickly mastered home-study Course.

### No Previous Experience Needed

You don't even need a high school education—don't have to know anything about planes or engines to learn the ground work of Aviation with my Course. Everything is clearly explained—illustrated by hundreds of pictures, drawings and charts—made as simple and easy as possible. You get all the information you need to pass the Government's written examination for Mechanic's or Pilot's Licenses, in a few short months. If you want to learn to fly, I can save you many times the cost of my Course on your flying time at good airports all over the country.

### There's No Time to Lose--Get My FREE Book Now!

Aviation is growing by leaps and bounds—while many other industries are slumping. Don't wait and let the other fellows get ahead of you. Think about your own future. Let me prepare you for a job paying \$30 a week or more—in Aviation. Get the FACTS. Mail the handy coupon on the right today—right now—while you're thinking about it. I'll send you my big FREE Book—packed with interesting facts about your opportunities in Aviation. Mail coupon NOW.



**Walter Hinton**

First to fly the Atlantic; first to fly to South America; first to explore the upper regions of the Amazon by plane. Flying Instructor in Navy for five years. Now giving ambitious men practical ground work training in Aviation at home. Mail the coupon below for your copy of his big new FREE Book today.

### Airplane Flight Included

Just as soon as you complete my training, I arrange a flight for you at an accredited Flying Field. There is no extra charge for this. My book tells all about it. Mail coupon.



## Mail for my big FREE BOOK on AVIATION NOW!

Walter Hinton, President  
Aviation Institute of U.S.A., Inc.  
1115 Connecticut Avenue, Washington, D. C.

935-G

Please send me a Free copy of your book, "Wings of Opportunity," telling about my opportunities in Aviation, how you will train me at home and help me get a job.

Name .....  
(Print clearly)

Address ..... Age .....

City ..... State .....

**WALTER HINTON, President**

Aviation Institute of U. S. A., Inc.

1115 Connecticut Ave.

Washington, D. C.

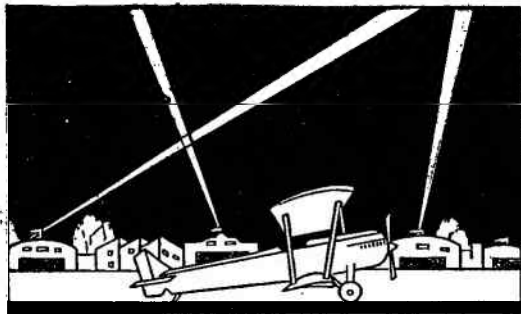

Three Magazines in One!  
Fiction, Fact, Model Building

*The New, Bigger, Better*

# FLYING ACES

A.A. WYN, *Editor*

VOLUME XXI

AUGUST, 1935

NUMBER 1

## EVERY STORY COMPLETE—NO SERIALS

<b>SCOURGE OF THE SPECTRE</b> . . . . .	<b>DONALD E. KEYHOE</b>	<b>4</b>
A routine mission sent Captain Strange to that field — where death lay in wait.		
<b>WINGS AWEIGH!</b> . . . . .	<b>LIEUTENANT H. LATANE LEWIS, II</b>	<b>8</b>
Thrills on board Uncle Sam's aircraft carriers.		
<b>DOG FLIGHT!</b> . . . . .	<b>JOE ARCHIBALD</b>	<b>11</b>
Major Garrity wasn't having a good time. Phineas was.		
<b>LONDON UNDER AIR ATTACK</b> . . . . .	<b>C. B. MAYSHARK</b>	<b>14</b>
Bombs over London — the story behind this month's cover.		
<b>CALLING ALL PLANES!</b> . . . . .	<b>COLIN KERR CAMERON</b>	<b>15</b>
People think the Army airmen can do everything — and they are right!		
<b>THE GRIFFON'S GAMBLE</b> . . . . .	<b>ARCH WHITEHOUSE</b>	<b>16</b>
Kerry Keen, sky sleuth, solves a strange new mystery.		
<b>SUICIDE SPANDAUS</b> . . . . .	<b>ORLANDO RIGONI</b>	<b>19</b>
Straight into a trap their C.O. led those grim men of the 16th Squadron.		

## MODEL MAKERS' SECTION

<b>WITH THE MODEL BUILDERS</b> . . . . .		<b>27</b>
<b>BUILD THE MARTIN DIVING BOMBER</b>	<b>JESSE DAVIDSON AND HARRY APPEL</b>	<b>28</b>
<b>AERODYNAMICS SIMPLIFIED</b> . . . . .	<b>AVRUM ZIER</b>	<b>35</b>
<b>FLYING ACES CANARD GLIDER</b> . . . . .	<b>JULIUS UNRATH</b>	<b>36</b>
<b>FROM THE MODEL BUILDER'S WORKBENCH</b> . . . . .		<b>36</b>
<b>FLYING ACES STRATOSPHERE PURSUIT</b> . . . . .	<b>NICK LIMBER</b>	<b>40</b>

## DEPARTMENTS AND FEATURES

<b>SNAPSHOTS OF THE WAR</b> . . . . .	<b>7</b>	<b>PILOTOPICS</b> . . . . .	<b>26</b>
<b>AMERICA'S ANSWER TO AIR THREATS</b> . . . . .	<b>10</b>	<b>JOIN THE FLYING ACES CLUB</b> . . . . .	<b>42</b>
<b>LIVES OF THE ACES</b> . . . . .	<b>18</b>	<b>FLYING ACES CLUB NEWS</b> . . . . .	<b>43</b>
<b>WAR PLANES ALBUM</b> . . . . .	<b>20</b>	<b>ALL QUESTIONS ANSWERED</b> . . . . .	<b>43</b>
<b>HAPPY LANDINGS</b> . . . . .	<b>22</b>	<b>AIR MAIL PALS</b> . . . . .	<b>44</b>
<b>FROM RACER TO FIGHTER</b> . . . . .	<b>23</b>	<b>MISSING WORDS CONTEST NO. 16</b> . . . . .	<b>45</b>
<b>WISECRACK-UPS</b> . . . . .	<b>24</b>	<b>IN THE NEXT ISSUE</b> . . . . .	<b>46</b>
<b>PICTORIAL FLYING COURSE</b> . . . . .	<b>25</b>	<b>ADVERTISER'S CONTACT</b> . . . . .	<b>61</b>
<b>HERE AND THERE IN THE AIR</b> . . . . .	<b>26</b>	<b>FLYING ACES STAMP TALES</b> . . . . .	<b>63</b>

Cover Painting by C. B. Mayshark

Published monthly by Magazine Publishers, Inc.; office of publication, 29 Worthington St., Springfield, Mass. A. A. Wyn, President; Warren A. Angel, Secretary-Treasurer. Editorial and executive offices, 67 W. 44th St., New York. Entered as second-class matter, Nov. 14, 1928, at Springfield, Mass., under Act of March 3, 1879. Title registered in U. S. Patent Office. Copyright, 1935, by Magazine Publishers, Inc. Nothing may be reprinted without permission of the publishers. Manuscripts will be handled with care, but this magazine assumes no responsibility for their safety. For advertising rates address **FLYING ACES Magazine**, 67 W. 44th St., New York City.

Twelve Issues, \$1.50

Single Copies, Fifteen Cents

# SELLEY-TEX\* ACCEPTED . . . as the solution to practical model building

*ENTHUSIASM from everyone who tries this NEW REVOLUTIONARY IDEA!*

## SELLEY'S exclusive FLYING MODEL KITS are AMAZINGLY SIMPLE TO ASSEMBLE

\*PAT. APPLIED FOR TRADE MARK REG.

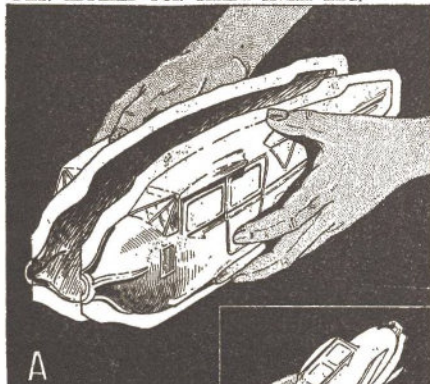

**Simple as ABC**

**A**—Fit together and cement the two moulded parts of the fuselage.

**B**—Cut away the border of excess fabric.

**C**—The result is a perfectly shaped fuselage in the form of a hollow shell, very strong and indestructible.

All other SELLEY-TEX moulded parts as listed are equally easy to build. They take the aggravation and perspiration out of model building.

**AT LAST! THE MODEL BUILDER'S DREAM COME TRUE!**

Here is the practical answer to your problem. Why pay "bargain" prices for worthless kits you cannot assemble. No amount of advertising-claims can change the facts. When you compare what you GET with what you PAY, SELLEY-TEX CONSTRUCTION SETS are INEXPENSIVE! They are more beautiful, easier-to-build, more realistic and finer performers. SELLEY invites you to make your own comparisons and prove the facts for yourself! Do it NOW!

A steady stream of congratulatory letters from all over the country pay tribute to SELLEY-TEX CONSTRUCTION SETS—the greatest advancement in the history of model building. To all of you who experienced the grief associated with the sad task of assembling a Balsa Stick Kit, here is a challenge! TRY a SELLEY-TEX Construction Set! If you do not find it to be the easiest, most practical method of building an authentic, true-to-scale model airplane, simply return it in good condition and your money will be refunded in full! So strong a GUARANTEE of superiority must represent extraordinary value. Order one today and judge for yourself!



**WACO D Military**



**4.00**  
25c Postage

WACO D MILITARY. A wealth of military detail characterizes this formidable prototype of the latest Army innovation, and what a flyer!  
The SELLEY-TEX moulded parts included in this kit are shown at the right. These together with special parts and materials as listed complete this outstanding value.

**A TYPICAL CONGRATULATORY LETTER**  
I believe you have something that will make the Model World sit up and take notice. You are about ten years in ADVANCE of all other model companies and have beaten a path for the rest to follow. You have really CONTRIBUTED a worthwhile thing to us modelers and I as one feel duly grateful. Lots of luck.  
(Signed) Homer D. Corwin,  
Bismark, N. Dak.

**SELLEY-TEX! AMERICA'S only MODEL KITS with MOULDED PARTS**

The manufacture of moulded parts takes more time, finer materials and more skillful workmanship, but it does make PRACTICAL construction sets! Our faith in this MODERN METHOD OF MODEL BUILDING is best shown by our discontinuance of fifty numbers of old fashioned Balsa Stick Kits!

**LISTED PARTS AND ACCESSORIES**

Finished scale flying, adjustable pitch metal prop, finished propeller shaft and rear hook, scaled wheels, with brass bushings, ribs printed out accurately on white sheet balsa, many special turned wood parts, finest grade of balsa wood, sticks, tail wheel and fork fittings, control horns and wire, pure para rubber, special bamboo paper, authentic markings, colored insignia, best quality cement, colored dopes, full size easy-to-understand plan, complete with all picture details. All the tools necessary to build model, such as CLAMPS—RAZOR BLADE, BRUSH, SANDPAPER

**ALL 24-INCH WING SPAN**



**SELLEY-TEX MOULDED PARTS FOR WACO D**

All SELLEY-TEX moulded parts are beautifully finished.

- 1—Right fuselage shell
- 2—Left fuselage shell
- 3—Bulkhead
- 4—Balancing ring
- 5—Motor 6—Cowl
- 7—Streamline cowl bumps
- 8—Pants shells
- 9—Pants strut fairing
- 10—Fuselage strut fairing
- 11—Bomb shells
- 12—Wing guns
- 13—Landing gear brace strut streamline fairing
- 14—Tail wheel fairing



**GOSHAWK 4.00**  
25c Postage

**GOSHAWK.** A powerfully attractive flying scale replica of the speedy Navy fighter and accurate to the minutest detail.

The following SELLEY-TEX moulded parts: Fully detailed fuselage, bulkhead, head rest, balancing ring, drag ring, bombs, belly tank, wheel shoes, shoe fairing, tail wheel fairing and a special fully scaled 9-cylinder motor, detailed with push rods, all the fine scale parts and materials as listed complete this very extraordinary value!

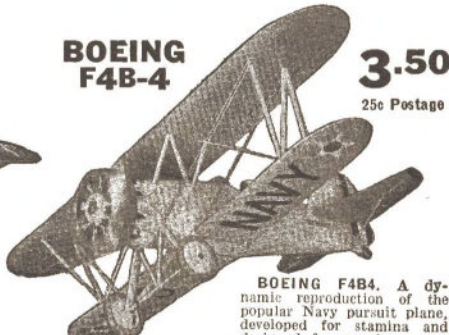

**BOEING F4B-4 3.50**  
25c Postage

**BOEING F4B4.** A dynamic reproduction of the popular Navy pursuit plane, developed for stamina and designed for speed.

The SELLEY-TEX moulded parts include fuselage sides, bulkhead, balancing ring, head rest, wheel fairing and tail-wheel fairing, special scaled 9-cylinder radial motor detailed with push rods and a drag ring. Also the many special parts and materials as listed come in every SELLEY-TEX kit. WHAT A VALUE!



**The NEW RYAN Sportster 3.00**  
25c Postage

**THE NEW RYAN SPORTSTER.**

An exceptionally realistic miniature, embodying every modern principle of light commercial planes to assure long distance flying. The SELLEY-TEX moulded parts included in this kit are as follows: Fuselage, balancing ring, nose piece, spinner, head rest, rudder fairing and combination pants and landing gear; these together with special parts and materials as listed complete this outstanding value.

**FREE!** Write for our beautiful, two-colored broadside containing illustrations and details about the new SELLEY line of incomparable SELLEY-TEX Construction sets. Send 3c stamp for postage.

**DEALERS!**

Cash in on the growing demand! Write for discounts, propaganda, etc.

Send 5c for Supply Catalog—Guns—Wheels—Props—Balsa, etc.

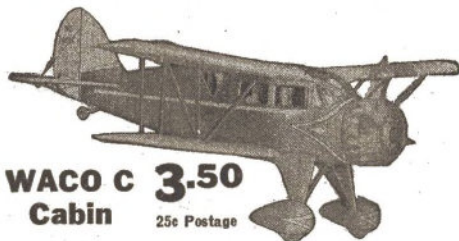

**WACO C Cabin 3.50**  
25c Postage

**WACO C CABIN.** A masterpiece of authentic model design, incorporating every scientific feature to insure maximum flying performance.

Fully detailed SELLEY-TEX moulded fuselage, bulkhead, balancing ring, cowl, cowl bumps, pants, pants fairing and a special full-scale 9-cylinder motor, with metal push-rods and a special moulded celluloid cabin windshield; the many special scale parts and materials as listed complete this amazing value.



**FAIRCHILD 22 3.00**  
25c Postage

**FAIRCHILD 22.** A magnificent example of practical model construction, embracing durability of structure and ease of performance.

The SELLEY-TEX moulded parts include fuselage, bulkhead, balancing ring, cowl, pants and pants fairing, special 7-cylinder radial motor to scale with push rods, and exhaust fairing, also all materials and special parts as listed complete this remarkable value.

**SELLEY**  
MFG. COMPANY, INC.  
Dept. 108  
1377 GATES AVE.,  
BROOKLYN,  
N. Y.

# Scourge of the Spectre

Orders to meet Secret Agent G-6 for a routine mission had sent Captain Philip Strange to that tiny G-2 field in the heart of the forest. But as his ship rolled to a stop and he stepped out onto a gray carpet of ashes, Strange knew that this was nothing routine—that something far more sinister lay behind it. For in the midst of those gray ashes was the crumpled figure of Secret Agent G-6, and his throat bore ugly marks that showed he had been strangled by skeleton fingers.

\* \* \*

*Illustrated by E. M. Frandzen*

## CHAPTER I

### THE KILLER OF QX

**T**HE smoke was a curious green. Philip Strange stared over the Spad's cowl as the ship droned down toward the gloomy forest. The flare he had released was settling into the smoke. As he watched, its white light changed to a brilliant emerald glow, casting a weird radiance over the Forêt des Rogues.

At first glance, the tiny G-2 field in the heart of the forest seemed entirely hidden by that peculiar greenish pall. But as the flare swung lower, Strange saw that the smoke was thinning, drifting away to the north. He could vaguely glimpse smoldering ruins below. Banking to windward, he sent the plane roaring down at the edge of the clearing.

There had been three shacks and a small canvas hangar, erected under the trees. All had been burned. A heavy, unpleasant odor came to Strange's nostrils as a wisp of the greenish smoke was hurled back by the prop. The descending flare was at two hundred feet, shining through the smoke like a great, blazing emerald. Strange banked for another quick glance. Scorched ground stretched away before him. In a moment he saw that the burned area was roughly circular, with a diameter of about two hundred feet.

At the southern edge of this dark circle, close to smoldering trees, lay the charred remnant of a plane. Sullen red embers were still visible. As the Spad thundered above it, Strange saw a crumpled figure on the unscorched ground fifty yards beyond. He leaned out of his cockpit for a hasty look, but almost at once the waning flare went out. He zoomed to clear the trees, climbed swiftly to drop another flare. As the Spad roared up into the night, his mind raced over the message which had cut short his leave in Italy:

*"Glad arm is healed. Have mission for you. Leave Venice today. Arrive QX by ten tonight. Prepare accompany R-6 on official trip to Marseilles. Confirm.*

*(Signed) JORDAN."*

QX was the isolated G-2 post which now lay in ruins below. R-6 was Lieutenant Jack Lorton, of the air intelligence unit. And "official trip to Marseilles" meant a trip over the lines in German uniform. Strange frowned down into the darkness. From the tone of

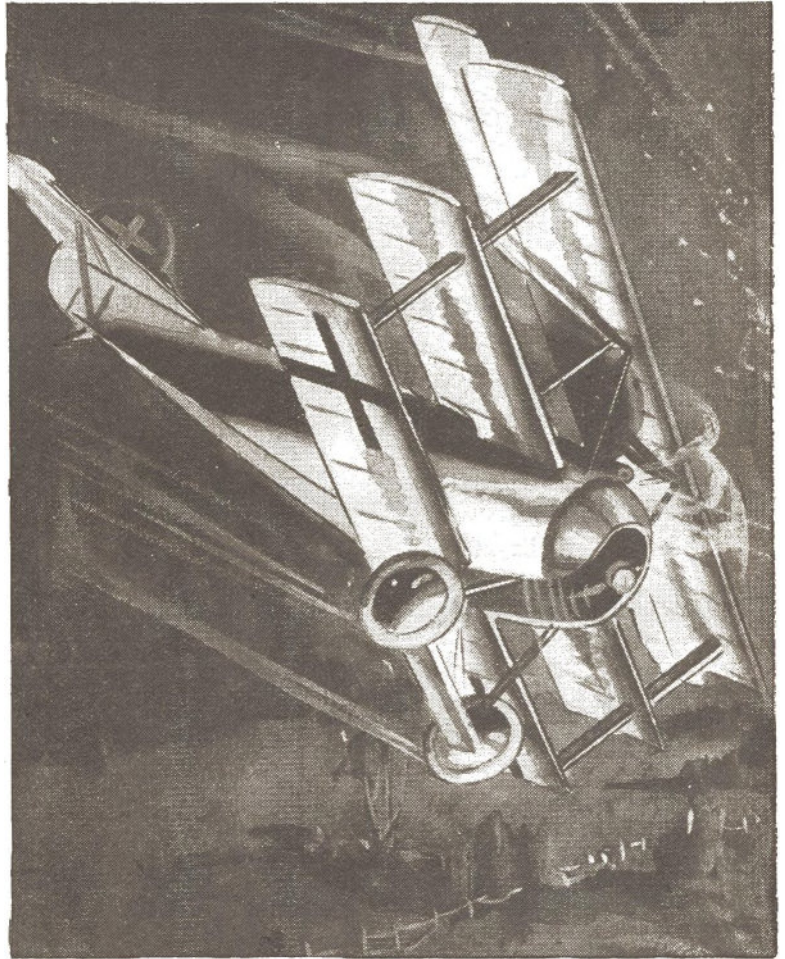

As Philip Strange in the Nieuport charged straight for the Fokker tripe, another enemy ship dived in, guns blazing.

the G-2 colonel's message, he had expected a routine assignment, but that scene beneath had held more than a promise of something sinister.

He pulled the second flare at two thousand feet, swiftly scanned the heavens, then dived for the field. The Spad roared down, leveled out under his expert touch. The wheels rolled through a carpet of ashes, and the ship stopped close to the crumpled figure. Strange left the Hisso idling, and jumped from the pit.

Tinted by the smoke, the descending flare threw an eerie light over the scene. It shone on a Luger which had apparently been dropped by the man on the ground. Strange picked up the gun, jacked it open. The magazine had been emptied. He tossed the Luger aside and bent over the inert form. A German field-gray coat, torn in two places, became visible under the emerald light. Goggles lay near by. The man's helmet was gone.

Strange turned the pilot over, clipped out an oath of astonishment. Seared into the man's face was the mark of a skeleton hand!

**F**OR a second, Strange knelt there, staring. Then he took a small flashlight from one pocket, switched it on. The greenish light might have played a trick on his eyes. The narrow, white beam spotted the man's face. This time, there was no doubt. The outlines of huge, bony fingers were only too clear.

Strange shivered. A flaming skeleton hand—it was as though some fire-crazed wretch had come out of

# AMAZING "PHILIP STRANGE" MYSTERY NOVEL

By Donald E. Keyhoe

Author of "The Traitor Three," "Valley of Vengeance," etc.



those ruins, dying. But that was impossible. If the flames had worked that fast, the man would have been dead. And there was no body near by.

Then what had done it?

Strange leaned down to feel for the pilot's heart, though he had no hope that the man was alive. Suddenly, against the glow of the flashlight, he caught a familiar something about the pilot's profile. He bent over the mutilated face to make certain.

"Good God!" he whispered. "Jack Lorton!"

His eyes filmed as he saw the agony frozen on those youthful features. Mechanically, he thrust his hand

under the *feldgrau* blouse. His seeking fingers found no response. A hard lump came into his throat. The last time he had seen Jack Lorton, the youngster had showed him the picture of a pretty blonde girl back in the States. They were to have been married as soon as the war was over. And now he was dead, killed by some terrible thing.

For a moment, Strange's eyes rested unseeingly on the dead agent's face. Then for the first time he glimpsed the tip of an ugly bruise on Lorton's throat. The collar was already unhooked. He pulled it farther open.

The G-2 man had been strangled by skeleton fingers!

As on Lorton's face, the telltale marks were scorched and black. Strange swept his flashlight over the dead man's body. Lorton's pockets had been turned inside out. His boots had been pulled off and tossed aside. Buttons were missing from the two bellows pockets of the field-gray coat, and the cloth was scorched in two places.

Strange's eyes narrowed. The searing hands which had strangled Lorton had searched him with a brutal haste. He stood up, gazed around grimly. There was no sign of the other men he knew must have been at the isolated post. Apparently, they had been destroyed in that mysterious fire. He started toward the smoking ruins, then halted as his light fell on an impression in the ashes.

It was half-filled with sifting green ash, but the mark of a skeleton foot was unmistakable. The imprint was huge. Strange measured it against his own foot, found it two inches longer. He shifted the flashlight. There were more of those bony marks, leading across that queer, burned circle. He followed them till they ended on grassy ground. Beyond loomed the forbidding expanse of the Forêt des Rogues.

The Spad was idling jerkily. Strange turned back. He was nearing the ship when he saw a small, dark object at one side. He stooped quickly. It was Lorton's missing helmet, wadded up with one strap buckled about it. Paper crackled as he unfastened the buckle.

A map had been crumpled up inside, one end burned away. Strange spread it on the Spad's wing, raised his flash. A penciled line ran from the QX field toward Germany, ending at the scorched edge. In the margin, partly obliterated by the charred edge, were some scribbled words.

*Warn everyone not follow skelet . . . .  
and can't be killed. Will burn . . . .  
and pilots. Only way get to base . . . .*

A little chill touched Strange's heart as he read again the words "can't be killed." He looked at the Luger he had found near Lorton's body. What hellish thing could it be which had gone unscathed through the hail of slugs from that gun?

**S**TRANGE carefully folded the map, put it inside his flying-coat. With a last look at Lorton, he turned to the Spad. He could send men for Lorton's body. Just now, it was his duty to get word of this to Jordan as quickly as possible.

He taxied the ship across the burned stretch, blipping the throttle to clear the fouled plugs. As the Spad thundered up from the field, he banked in a climbing turn and headed south. Jordan's message had come from the G-2 dugout near Pierrefitte, which lay just back of a little crook in the lines. The 53rd Pursuit drome was not far beyond, lying between a highway and a small river. He set his course for the drome, climbed to three thousand feet for the short hop.

The clouds were not much higher. He flew under them, handling the controls like an automaton, his mind on the queer problem. Once a javelin of moonlight struck down through a break in the clouds, catching his lean face in repose, a repose it seldom knew. Even when playing no rôle, he frequently simulated the swift change of expressions which had made him a great actor as well as a super-spy. So expertly had he learned to control his mimetic muscles that he could, even without make-up, change his face so that it seemed that of another man.

Swiftly, his rapierlike brain raced over the puzzle, snatching at theories, probing their fallacies, rejecting them before they were hardly formed. Always, since he could remember, it had been like that—a leaping to conclusions with barely a consciousness of the in-

termediate steps. His mind made him a man apart.

It had been this uncanny brain, with its sometimes telepathic power, which had labeled him as a "boy prodigy" in his early years—years he had tried to forget. He had fled from a greedy uncle who had put him on the stage; he had wandered over the world, learning curious things—foreign tongues, the magic of Yoga, queer doctrines of the Orient. The war had brought him back, had made him an ace—but not as he had hoped. Captain Philip Strange had become Chaumont's "Mental Marvel"—the phantom ace of G-2.

The Spad roared on through the night. In a few minutes the darker blur of the Forêt des Rogues gave way to an open stretch. Strange could see the faint gray of the river which wound near Pierrefitte and past the drome. He was slanting down in a long glide when warning signals silently beat through his brain. He jerked the throttle, banked sharply. He heard no sound of another ship, yet that peculiar sixth sense he had so fully developed told him he was not alone in the sky.

The moon had gone into the clouds, leaving the night an ebony black. Strange twisted around in his cockpit, looking for the exhaust flares of another plane. Suddenly there was a flash of light below and ahead. He spun about.

A huge ball of green fire was settling down toward the drome!

**I**T swelled while he stared at it, spreading until it looked to be at least a hundred feet in diameter. By the weird glow, he could see men running frantically from barracks and huts.

Gunning the engine, he dived steeply. The ball of green fire was less than a thousand feet from the drome. It settled slowly, rolling and bulging like an enormous "flaming onion" hurled from some giant rocket. Strange slitted his eyes to see against the glare. He could see nothing above that green, oily fire. Yet he knew that its light meant death.

The heat forced him to rudder away as he dived past the flaming mass. Below, a scene of wildest confusion was revealed in the emerald light. Men were running in every direction, from under the huge ball of fire. A Nieuport swung out from the line, charged madly down the field. A little group of officers had dashed from the headquarters hutment. Several of them ran toward a big Staff car. Two reached it just as it started. The others whirled desperately toward the bank of the river which bordered the field.

Two more Nieuports sped across the drome as Strange pulled up at one side. The first one had zoomed up on the other side of the blazing green mass and disappeared.

Strange's eyes strained to watch it. Above the thunder of his engine Strange caught a high-pitched howl. The next instant, a flame-wrapped ship plunged from the center of that great ball of fire. Strange gave a cry of horror. That poor devil in the first Nieuport . . . .

"My God!" he cried hoarsely.

Through the mantling flames he could see the blackened skeleton of the pilot. In those few seconds, the green fire must have burned all the flesh from his body.

Sick, almost nauseated, Strange was tearing his eyes away when, before his stunned gaze, the skeleton moved. With a screech, the flame-covered ship came out of its headlong dive. Tongues of greenish fire trailed from its wings and tail as it shot up in a violent turn. Through the flame and smoke which eddied about the pit, Strange saw a blackened skull turn toward him. Fire seemed to flash from the empty, hideous sockets. Then the charred and smoking ship lanced up into the night.

Almost paralyzed, Strange stared after it. This was madness! That pilot was dead—nothing but charred bones! He couldn't be flying that ship!

(Continued on page 45)





# Snapshots of the War

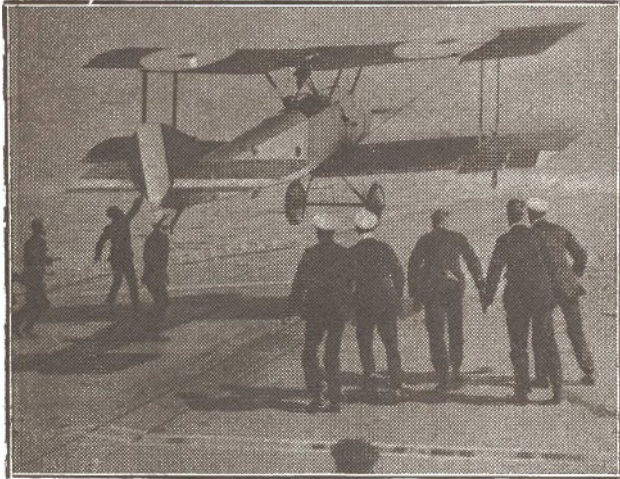

Canadian Official War Photo

Proving that they had aircraft carriers during the war. In this, we have a young pilot about to prove it. The Sopwith Pup, fitted with a Lewis gun through the center-section, has over-shot the landing deck of the Furious. The ship dived into the waters of the North Sea.



Canadian Official War Photo

This Fokker D-7 was shot down inside the Canadian lines by a Canuck airman. The German pilot tried to set fire to his ship before he died, but a flock of Canadian and Australian infantrymen nailed him before he completed the job.

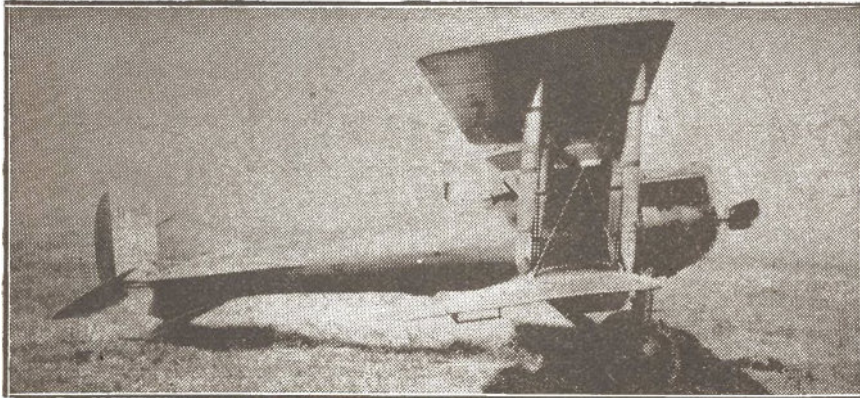

Above: We have had a lot of inquiries on the French Nieuport fighter known as the 29 C-1, which came out late in 1918. Here it is, with its 300-h. p. Hispano Suiiza engine and the Lambda radiators under the fuselage. It was, of course, an improvement on the Nieuport 28, and considerably like the British Nieuport Nighthawk. In some records, it is listed as the Nieuport-Delage.



Right: One of the most pathetic pictures of the war. This shows Georges Guynemer, the great French ace, dressing before his last flight. While this was being taken, high officials were rushing from Paris to persuade Guynemer to give up active service flying for a long rest.



Canadian Official War Photo

Here's one of the Gothas that tried to bomb the Canadian base hospital at Etaples. Six nurses lost their lives and many wounded men were killed, but British night-flying airmen trapped this night raider and brought her down. A number of nurses who escaped are collecting souvenirs.

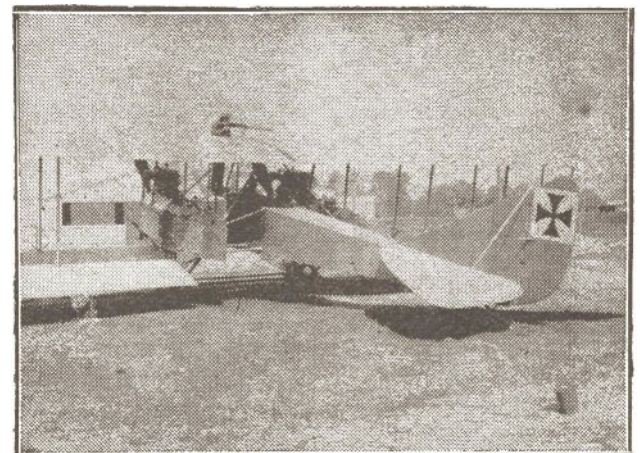

Canadian Official War Photo

A little known German bomber which came out in 1917. This is a two-engined L.V.G. fitted with two 180 Argus engines. Note the platform set in front of the open pilot's cockpit, arranged so that the gunner can fire out over the top plane. An uncomfortable and dangerous post in any man's war.

THRILLS  
ON BOARD  
UNCLE SAM'S  
AIRCRAFT  
CARRIERS

By Lieutenant  
H. Latane Lewis II  
Author of "Leathernecks Aloft," "Chut-  
ing the Chutes," etc.

✱ ✱ ✱

Here's a close-packed formation for you. Below, you see United States Navy planes lined up on the deck of the U.S.S. Saratoga. We can count over sixty-five, not counting the one that has taken off into the clouds—and whether that's accurate or not, it's plenty. There's not much more room for parking on that deck!

Official Photograph, U.S. Navy

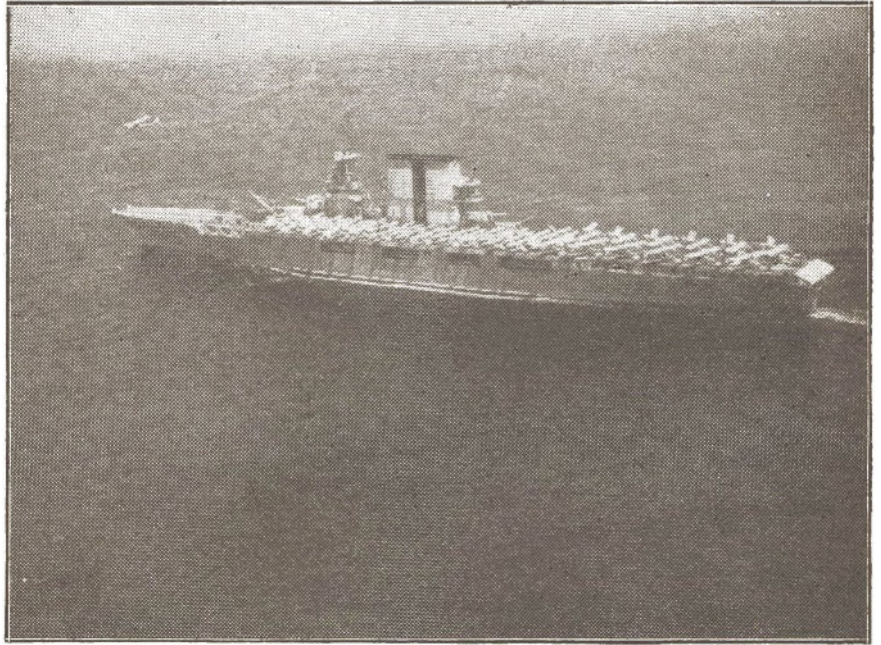

# Wings Aweigh!

**T**HERE was the throb of many motors in the air off the Virginia capes. High against the blue sky, a long string of specks like a flock of wild geese turned and wheeled downward.

Pounding her way through the heavy sea was the *U.S.S. Ranger*, the white foam spreading back on either side of her gray bow. Her flight deck was cleared for action, and she was headed into the wind.

As the planes came lower, they swung into single file. Soon the first was approaching for a landing. Standing near the stern of the carrier was the landing officer, with a flag in each hand to signal the incoming pilot if he was approaching too high, too low, or too far to

the right or left.

Suddenly there appeared on deck two grotesque figures, garbed from head to foot in heavy asbestos suits and carrying fire extinguishers. Nicknamed the "Hot Papas," these men were ready to rescue the pilot in event of a crash followed by fire. Enlisted men operating motion picture cameras trained lenses on the plane. If it had appeared that there was going to be a crack-up, they would have begun grinding out film so that it could later be determined just what the cause of the accident was.

Closer and closer the plane came towards the stern, swaying slightly as it jockeyed for position. The for-

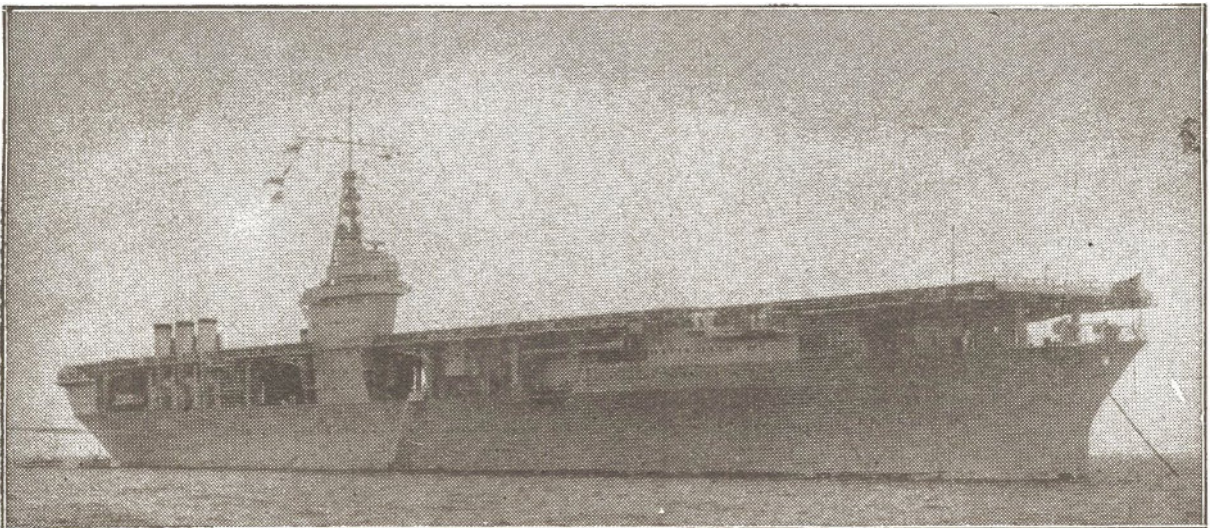

Official Photograph, U. S. Navy

The *U.S.S. Ranger*, moored off Hampton Roads, Virginia. In spite of its size, this great structure can be moved across the waters of the earth at a speed of about 40 statute miles an hour—and all the time be able to protect itself with its own guns. A floating fortress!

Ready for battle! Here are some of Uncle Sam's best torpedo planes that have taken off an aircraft carrier and are speeding through the skies in battle formation.

Official Photograph, U. S. Navy

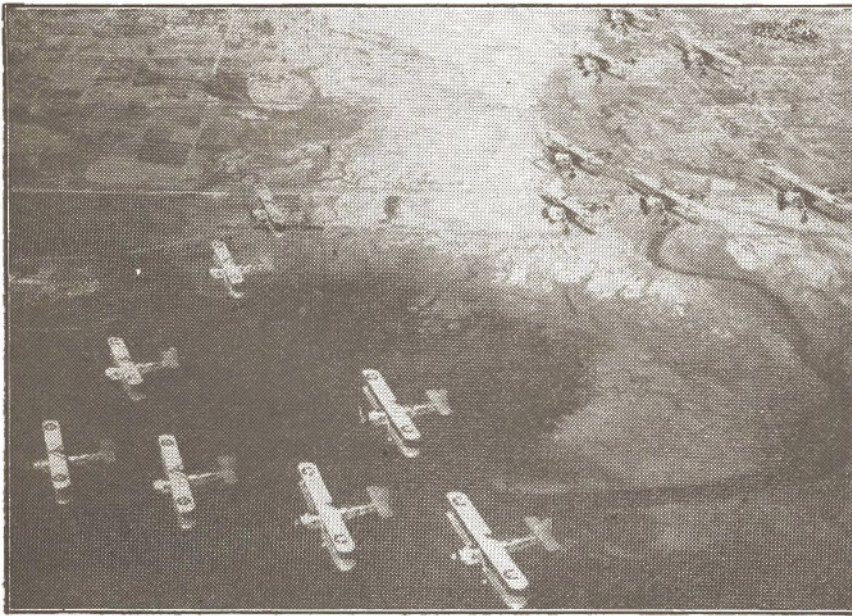

ward speed of the carrier created a wind over the deck and cut down the landing speed of the plane. As soon as its wheels touched the deck, the plane engaged the arresting gear and was brought to a stop in a surprisingly short run. This arresting gear is a secret of the U. S. Navy and details concerning its construction and operation are guarded jealously. When the plane was down, it got out of the gear immediately and taxied forward out of the way, for there was another ship coming in right on its tail.

One by one, at intervals of only a few seconds, the other machines came to rest upon the *Ranger's* broad deck until the entire brood was once more aboard.

Thus does our Navy take its flying fields with it when it goes to sea. The *Ranger* is a vast floating city of some 1,400 souls, with food and lodging for all; electric light and power; with its own water supply and refrigerating plant; a complete telephone exchange and facilities for communicating by radio with the whole world; with a post office, laundry, barbers, tailors, and movie theater. Four large squadrons can operate from its deck. And in spite of its size, this great structure can be moved across the waters of the earth at a speed of about 40 statute miles an hour, and all the time able to protect itself with its own heavy guns.

One's first and most vivid impression of the *Ranger* is the immense size of its flight deck. It is 727 feet long and 80 feet wide—a real landing field, rather than just a floating hangar. But when you're up above and coming in to land, it looks about the size of a postage stamp. A huge storage space is built within the hull of the carrier, and the planes are transported from the deck to this space by means of a large elevator. Here, too, are shops where all manner of repairs can be made to planes, engines, and other equipment.

The squadrons based aboard the *Ranger* are VF-3B with 18 fighting planes; VB-3B and VB-5B with 18 dive bombers each; and VS-1B with 12 scouting or observation planes. In addition, there are a number of other planes which bring the total up to 70.

Some of the signals that carrier pilots use when in formation are an eye-opener to the uninitiated. It is, of course, necessary that hand signals be extremely simple for fighting plane operation, since one of the pilot's hands is likely to be occupied with the business of flying. For the same reason, the signals should be as expressive as possible.

Illustrating the feature of expressiveness are the signals for "Forced Landing" and "Leaving Formation." The first, meaning, "I am in trouble, having

☆☆☆

"Anchors Aweigh!" was the old Navy cry, but today we add a new one—"Wings Aweigh!" For Uncle Sam's seagoing forces of the present time count their airmen as one of the most important branches of the service. And working with those airmen are the huge aircraft carriers from whose broad decks the fighters, bombers and observation planes take off—and on whose broad decks they come home to roost. Thus does our Navy take its flying fields with it whenever it goes to sea.

☆☆☆

forced landing," is signaled by the pilot's laying his head on his arm, as if he were going to break down and cry. This is commonly referred to as the "weeping out loud signal" and is one which it is hoped will seldom be used. For leaving the formation, the pilot indicates he is shoving off by saying "Goodbye" in an affectionate manner, fingers to the lips and a kiss tossed to the next in formation.

Another squadron has evolved a system of hand signals to use during radio silence or in event of radio failure. A code of letters is sent by dot and dash, using the open palm for dashes and the closed fist for dots. Numbers are sent by holding up fingers.

**L**ANDING at night on a carrier deck is one of the most spectacular and dangerous of all Naval aviation maneuvers. It is only fairly recently that formation flights in total darkness have been attempted. Visual signals, such as are used in daytime, are of course out of the question. The leader of a squadron gives orders by blinking a light carried on his plane. Lights of different colors are also used to designate the leaders of the various sections in the formation. The first section is led by a plane with a red light; the

(Continued on page 76)

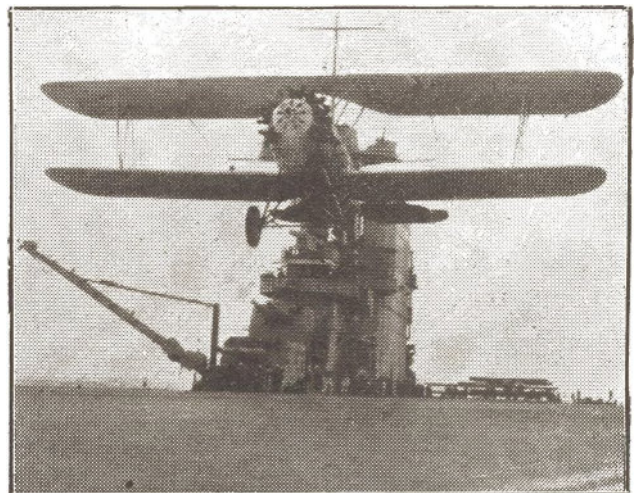

Official Photograph, U. S. Navy

An interesting close-up of the U.S.S. Lexington, showing a Boeing that has just lifted its wheels from the deck. Other Boeings are seen in the background, waiting for their signals to take off.

# America's Answer to Air Threats



Official Photo, U. S. Army Air Corps.

If it's fighters they want, here's a formation of Boeing P-26A's out of March Field, doing their stuff. Let them try and break up this attack of the fastest air-cooled fighter in the world. When they can fly like this, they will take plenty of stopping.

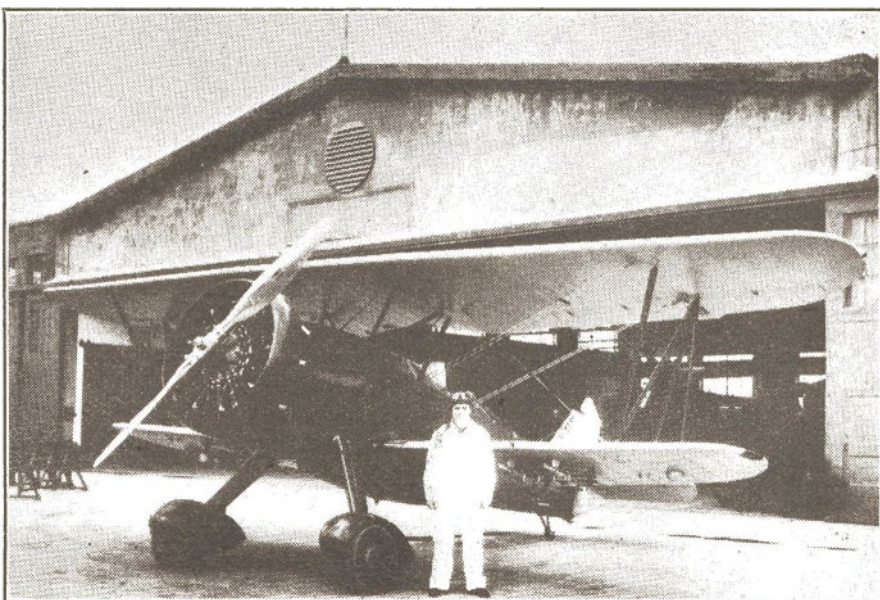

Japan saw what we had in the Curtiss Hawk when Jimmy Doolittle, now a test pilot for Curtiss, put this Army single-seater through its paces over Shanghai recently. Here's a real close-up of one of the finest ships of its type in the world.

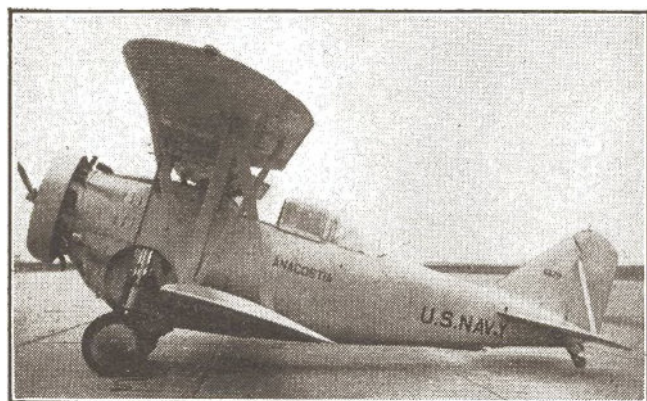

Above: The Navy is buying lots of these new Grummans fitted with the 620 Cyclone engine. This ship does well over 200 m.p.h. and boasts a rare armament, retracting wheels and special equipment for flying deck work with the aircraft carriers.

Right: And if it's bombers—how about these 200-m.p.h. Martin B-10 bombers in attack position? Note how they fly as close as the single-seaters and carry out their maneuvers with all the skill of the lighter jobs. The fastest bombers in the world, too.

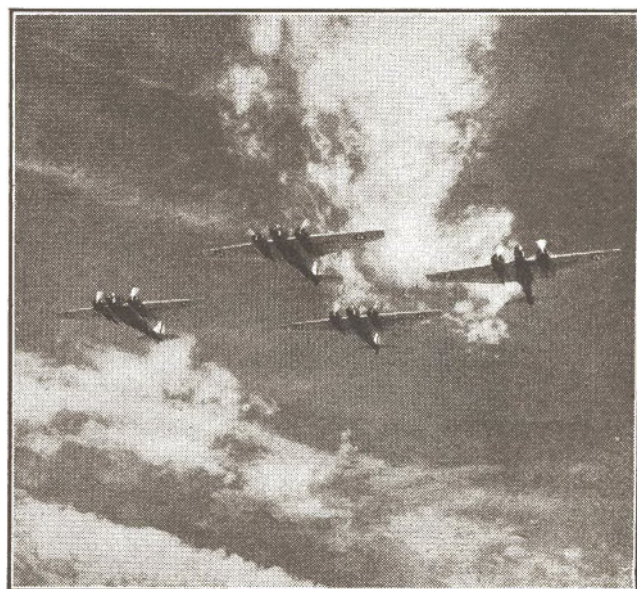

Photo from Triangle Photo Service.

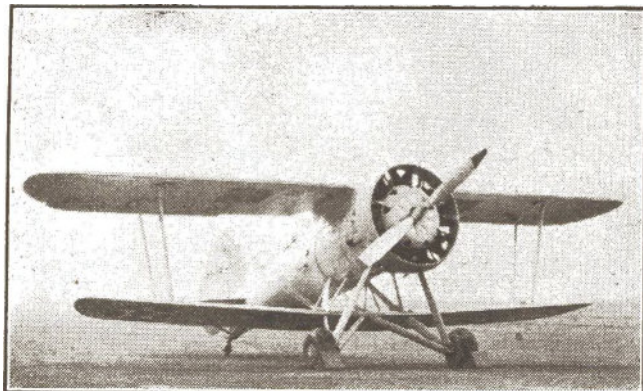

Photo from Joseph Nieto

The Army has a two-seater fighter in this Berliner-Joyce FJ-2 that compares with any in speed, equipment and fighting ability. The position of the fuselage with reference to the top wing gives the pilot and observer a rare visibility zone. It uses the Pratt & Whitney Wasp.



This new Vought O3U-3 powered with a 600-h.p. "Wasp" is the Navy's best bet where two-seater fighters are required. This is an improvement on the old Corsair and packs high speed and many high-caliber guns fitted under the cowling and inside the wings. Note the heavy gun in the upper center-section.

One rock nudged the tail of von Bountz's battle bus as Phineas' two-seater headed toward the lines.

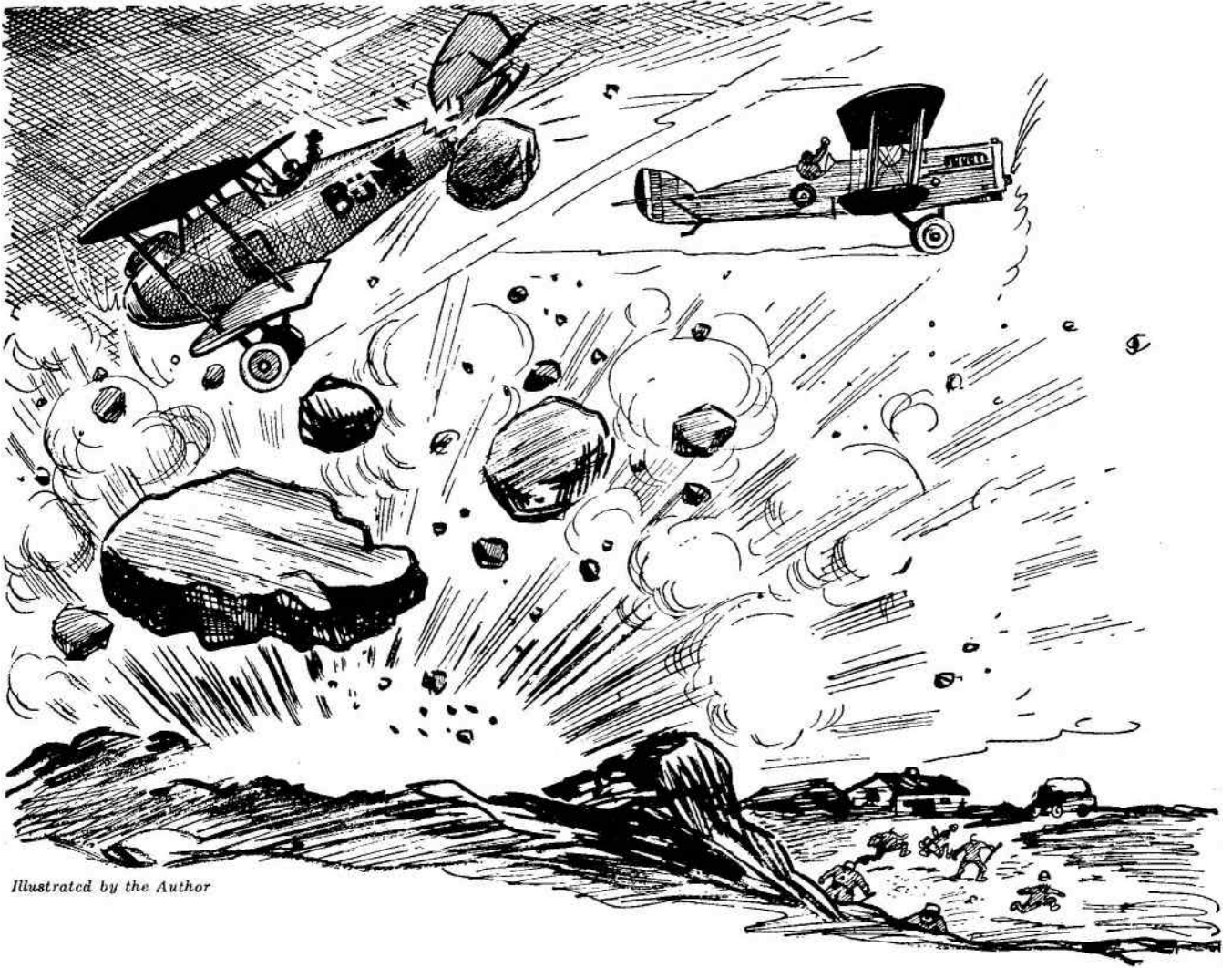

Illustrated by the Author

# Dog Flight!

PHINEAS—AND ROLLO—MAKE HISTORY

By Joe Archibald

Author of "Rice and Shine," "Prop Eyes," etc.

**A** FLIGHT, Ninth Pursuit Squadron, Major Rufus Garrity commanding, was taking quite a cuffing about by a Boche *Staffel* between Souilly and St. Benoit. The Spad quintuplets, led by Flight Leader Howell, seemed to be out of form, like a star actor in cauliflower alley who had spent the night before the big fight eating pickles, ice cream and fried oysters. It seemed as if they just didn't care.

Lieutenant Phineas Pinkham did not appear to be interested in the *mêlée*, even when a Heinie bullet ripped through the flying coat, wrapped around his torso and went on its way to smash into the dashboard. By force of habit he sideslipped, heaved a sigh, and gingerly picked a triangular piece

Major Garrity wasn't having a very good time. The Brass Hats were yelling at him so loud that he could have heard them if he'd been in the Sahara Desert without a phone. And Phineas Pinkham had taken to boiling black thread and hanging it up on the trees to dry. Yes, the whole war looked nuttier than a squirrel's commissary.

of glass out of his proboscis.

"Poor Rollo," the Boone-town, Iowa, contribution to the U.S. Flying Corps lamented. "It's just like murder. Well, it ain't goin' to be me. I'll make the bums toss up and—haw-w-w-w, I never lose!"

Br-r-r-r-r-r-r-r-r! Phineas, for the first time, showed signs of shock.

"Why, it's the Heinies! Where did they come from?" he yelled. But the Pinkham heart was heavy—too heavy to be lifted up and put to

work. So it was well that a flight of British S.E.5's was abroad that day. The beefeaters came tumbling down from a higher sky shelf and began to spread a very thick coat of shellac on the checkerboard Albatrosses, while the members of Garrity's outfit started toward

Bar-le-Duc and, strangely enough, wished that it were a thousand miles away.

Three sad-looking pilots climbed out of their battle wagons back on the drome and plodded toward the French farmhouse. Major Garrity heard them come in. Their boots sounded as ponderous as if they were weighted down with lead like deep-sea divers' kicks. He came forth to greet them.

"Well, little rays of sunshine," he growled, "you might as well start figurin' which one it's goin' to be."

"It's plain murder!" Phineas Pinkham yipped. "You know how tender my heart is. You go ahead, Howell, as you haven't finer feelings like me. I—"

Suddenly a prolonged "Ow-w-w-w-w-w-wr-r-r-r!" sounded outside.

"There!" exclaimed the freckle-faced pilot indignantly. "Could you go right out an' kill him now? Why, he's callin' for us."

The Old Man toyed with a piece of army ordnance for a while, then laid it down on the table. "Toss up for it," he barked. "Rollo goes out today. If you want to blindfold him—"

**N**OW, Rollo was an aged pooch of doubtful lineage. Rollo's dog days were about at an end. For the past month he had been mooching around the drome, having chosen it as a sanctuary in which to rest his aged bones. Rollo was short of breath, housed quite an assortment of fleas, was afflicted with various rheumatic pains and dragged one leg a bit, once having tried to outkick a mule. No mistake about it, Rollo was in the sere and yellow leaf.

Nevertheless, the pilots of the Ninth had welcomed Rollo, had even gone to the bother of building him a diminutive Nissen hut. It was Phineas Pinkham himself who had presented the canine octogenarian with a collar made out of a Brass Hat's Sam Browne belt.

Major Rufus Garrity, however, prided himself on being humane, not that his buzzards agreed with him. At one time, the Old Man had been head of the S.P.C.A. back in the States, and he told his varlets that he knew an act of mercy when he saw one.

"Listen," he had growled the night before, "Rollo is away across the field, but you can hear the mutt breathe. He's dead, but he just won't lie down. He's got to go before he suffers any more."

"I wish somebody 'round here would git short of breath," Phineas had pushed out. "Then we could shoot him. Haw-w-w!"

"Don't look at me like that, you spotted baboon!" Garrity had bellowed. "Rollo goes West tomorrow. It's up to you three kindhearts who gathered him to your bosoms. One of you—"

And so now the zero hour had come.

Ow-w-w-w-w-w-r-r-r-r-r-r!

"Rollo wants his supper," opined Phineas. "My heart's breakin'."

"Well," Captain Howell gave in, "get out a coin. We might as well get it over with."

"A coin?" repeated Phineas, trying to hide a sudden surge of exultation. "Oh, boys, come on, Bump, you nickel-nurser!"

The trio of buzzards displayed as many coins. Phineas' bit of silver, however, had never come from the U.S. Mint. It had heads on both sides.

"I take heads!" he cried. "Haw-w-w-w-w! Well?"

"Odd man wins," yipped Howell. "All ready?"

"Wait a minute," howled Phineas, as a thought struck him. "That's not the way I play. I—"

"I'm your superior," Howell reminded him belligerently. "Come on, slap that coin down on the back of your hand, you big ape!"

Phineas obeyed, a premonition of disaster gnawing at his core. Hands lifted.

"Tails," spoke up Bump.

"Same here," chuckled Howell. "What've you got, Carbuncle? Heads, huh? Ha, ha! Well, here's the cannon. Just turn your head when you shoot."

"I protest," blustered Phineas. "It ain't fair. I—"

"That trick nickel, huh?" grinned Bump Gillis. "Me an' Howell figgered that out. Well, Carbuncle, you know what Lincoln said. You can fool all of the people half of the time and you can fool half of the people half of the time—ha, ha! Say goodbye to Rollo for me."

Major Rufus Garrity had never felt happier. Phineas turned to him.

"Hm, uh, Rollo ain't so old," he began. "How 'bout givin' him two more days? Maybe his arteries'll loosen up an'—"

"You know my orders!" Garrity huffed, like the leader of a wolf pack.

"Awright!" snorted Phineas, picking up the gun. "Awright! When you pass a butcher's shop again, swap your heart for one that come out of a mule. I hope Rollo comes back to haunt you."

**F**IVE minutes later, work on the drome came to a standstill as Phineas Pinkham trudged slowly toward open country. He was leading Rollo by a length of rope, and the pooch maneuvered in the Pinkham wake as fast as its onus of infirmities would allow.

"You kin hear the kiwi creak from here," declared Sergeant Casey. "It's good riddance."

For a mile Phineas Pinkham plodded on, not daring to turn around and look Rollo straight in the eye. Then he slanted away from the sunken road just as a U.S. staff car came lurching and clattering around a bend. In his palmy days, Rollo would have jumped, but in his present state of hale and heartiness, Rollo would only have shivered if he had sat down on a thistle. There came a yelp, and Lieutenant Pinkham spun around like a top. Rollo was still at the end of the rope, but he was quite defunct.

"Why—er—Rollo!"

Rollo!" hollered Phineas. "Why, you bums!"

The staff car stopped. Two Brass Hats climbed out. One looked at the late Rollo and muttered an elegy. The other approached Phineas. Abruptly the Pinkham scion clamped his hands to his face and sat down on a rock.

"Oh-h-h-h-h-h-h-h-h! Oh-h-h-h-h-h-h-h!" he moaned.

"Sorry," apologized the brigadier. "I'll bust that dough who was drivin'. I'll—"

Phineas' shoulders shook. His big nose erupted quite an assortment of sniffles. He looked up at the colonel.

"That w-w-won't bring back R-Rollo!" he said from the depths of apparent grief. "Y'know, a dog an' a horse are man's best friend. Woe is me! What'll I do? I don't care what happens now."

"Touching, eh, what?" the colonel said to his mate. "Flyer—his mascot, no doubt. Well—er—the only thing we can do is—how much money you got, Boggs?"

"T-Twenty francs," came the reluctant answer.



"Why, Casey," said Phineas, "you can see it is only black thread."

The colonel touched Phineas on the shoulder. "Here's fifty francs, my good fellow. All we can do. Buy yourself another mascot, perhaps?"

"Money!" gulped Phineas. "For Rollo? Why—that is—why—" But the pilot extraordinary pocketed the currency in the midst of his indignant protest. The colonel and his companion got back into the A.E.F. boiler and soon were out of sight and hearing.

"Oh, boys!" grinned Phineas. "Fifty smackers! What was it Lincoln said? Well, Babette, I'm on my way, fair maid, and will be in Barley Duck anon." He looked at Rollo's remains, experienced a brief pang, then eased the old bones out of the road. He took time to build a cairn of rocks over the remains.

"Adoo, ol' boy," he said. "It's a rotten wind that don't blow somethin' good my way. Fifty francs! And I was quite short. Oh, boys! The Old Man will not have a leg to stand on as I'll say I was struck by grief and had to drown sorrow in an *estaminet*. Phineas Pinkham, it's a caution how you arrange things. Here I have to exterminate Rollo and he's taken out of my hands and what is put in his place? *Argent!* I guess the Pinkhams was church-goin' folks. Haw-w-w!"

Phineas caroused as long as fifty francs would allow him that night. Babette never seemed fairer. The cognac never was more potent. It was with light heart and lighter head that the jokester from Boonetown arrived at the Frog farmhouse late that night. Major Garrity was waiting up. Several pilots had fought off sleep to keep the Old Man company.

"H'lo, bums!" said Phineas in greeting. "You'd ought to've seen the look in Rollo's eyes. It was awful. Touched me to the quick." He paused to flick an imaginary tear aside. "When—I—th—think of it, I git a lump—"

"You'll get another one," the C.O. cut in. "You big—"

"It was like murder. I says to Rollo, 'This'll hurt me worse than you,' " Phineas proceeded, undaunted. "Then you know what he did? He refused the blindfold and says, 'Bow-wow!' Then he sits right up when I pointed the gun. I turned my dome an'—"

Major Rufus Garrity started to applaud. "*Encore!*" he hooted. "Pinkham, you hybrid lemur, we had company while you were gone. Colonel John J. Butterby was here. He told us quite a sad story about how his car ran over a pooch. There was a rope tied to the mutt, and attached to the other end was a big, flap-eared liar by all the clocks in—"

"Huh?" gulped Phineas. "Why—er—are ya sure?"

"Yes," cut in Howell, "and he sat down at this very table and dug into a bag of peanuts you left here. When he cracked one open, it blew up in his face. He lost half his mustache and one eyebrow. Fifty francs, huh?"

"That is pretty small pertaters for Rollo," Phineas said indignantly. "What's the difference how Rollo went West? It was me who didn't have the heart to shoot him so I says I will get him run over by a truck or—well—"

"I told the colonel," Garrity added his bit, "that you were taking Rollo out to shoot him, anyways. The Brass Hat—"

"Now that is a pal for you!" erupted Phineas. "You would blab out a deathbed secret. Awright, go ahead. Nobody can prove—"

"The colonel is coming after those fifty francs when he calls again," the C.O. cracked. "And, seeing that you have two months' pay docked already, well—ha, ha!"

"I will go into bankruptcy," grinned Phineas. "That'll fool him. Adoo, bums! I must have my sleep."

"Brought a bottle with you, I see?" the major suddenly tossed out. "Bought with your ill-gotten gains. Hand it over! You think I'm porous or what? I marvel at your generosity. Hand it over."

"Gosh, a guy can't have nothin' around here. Of all the hogs—" complained the man of the moment.

The Old Man took the bottle, yanked out the cork. Squ-ish! Black liquid hosed out. Major Garrity's physiognomy, in a trice, assumed the ebon hue of an end man in a minstrel show. The bottle fell from his limp fingers. He spluttered, then got up slowly.

"Don't forget," Phineas yipped as he paused in flight and banked around in the doorway. "You made me give



Rollo was in the sere and yellow leaf—and no mistake!

it to you. I know discipline. I always obey superiors as—"

Crash! It was quick work—picking up that bottle and heaving it. But Phineas Pinkham had not moved like a snail with leg irons. He was halfway to his hut when the bottle broke up.

**B**UMP GILLIS arrived at the cubicle a couple of minutes later.

"I hope you thanked the Old Man," grinned Phineas, as he pulled off a boot. "That bottle was for you, Bump. I never forget you when I go to town, you know that. Haw-w-w-w! Well, it has been fun, huh? I miss Rollo, though, don't you? He generally barks taps at this hour."

"Some day I will kill you," gritted the Scot. "Shut up and make believe you bunk alone. I—phew-w-w-w-w! What's that smell? What're you boilin' in that kettle? If it's your socks, I move out."

"Aw, it's nothin' but a lot of black thread I'm boilin' in oil," his hutmate assured him. "There's somethin' else in it, too, but you wouldn't understand, Bump. I don't see why they didn't build schools in Scotland. Ah—er—what did the Brass Hats want, huh? I bet it was that shell dump that is dug under a cliff, huh?"

"What did you think—that they come to paint Easter eggs?" snorted Bump.

"Haw-w-w-w-w-w!" complimented Phineas. "That was almost funny, you ol' highland-finger, you!"

Bump crawled into bed and disdained reply to this latest insult. Phineas went over to the little oil stove he had filched from a deserted Frog farmhouse. He stirred the contents of the kettle and then reached for a book on a near-by shelf. Turning to a page he had marked, he read the fine print under a heavier caption, **HERMES' OINTMENT**.

"Nope, I haven't left anythin' out," the red-headed witch doctor chuckled. "It's wonderful, the progress of science."

An hour later, Phineas turned down the wicks of the  
(Continued on page 69)

# London Under Air Attack

THRILLING STORY BEHIND THIS MONTH'S COVER

By C. B. Mayshark



**WAR!** The word twangs a different chord in the heart of every man. To the Frenchman, it means a charge toward Paris—or Bayonet Trench outside Verdun. To the American, it means Chateau Thierry or the Argonne; to the Belgian, the remorse of Leige and the ravaging of a neutrality; to the Russian, the helpless swamps in front of the Masurian Lakes; to the Italian, the bloody Piave.

But to the average Englishman, whether he wore khaki or blue, war means air raids on London!

And well it might. When the news reached the trenches on that eventful day in 1915 that German airships had raided peaceful English towns on May 31st, raining incendiary and high-explosive shells on peaceful and unarmed British towns, the horror of war was probably first realized, after nearly a year of bitter fighting.

The English saw their kinfolk battered and mangled, buried under massive piles of masonry. Civilian names were listed in the casualty columns. From that day on, the Englishman knew he was in a war, and in retaliation, British airmen braved distance and bombed Karlsruhe. The French bombarded Baden. The British captured Kut-el-Amara and German South-West Africa. They raced across No-Man's-Land and completed the capture of the area around Neuve Chapelle. They began a new march on the Dardanelles. And war today still means air raids on London.

The moment the German plans for a gigantic army and a great air force were announced, the British remembered the air raids of 1914-18. They set to work at once to strengthen the air defenses around London, the capitol of the Empire. Forty-one new squadrons were ordered, and recruiting for the R.A.F. leaped to amazing figures. Old flying men swarmed back to the colors. Youngsters hardly out of public school rallied to the call. Their England, which had once denied the charges that Germany was rearming, was threatened again, just as she was in 1914.

She would need more Warnefords, more Robinsons, more McCuddens, more Balls and more Mannocks. Some one had to face the foe which threatened again. No one ever knew the surge of air-mindedness that swept England last March. No one probably ever will. But the gauntlet, the flying glove, was taken up, and again England was ready.

But there is one difference. Germany knows today that she must never make the mistake she made in 1914 when she allowed England to get into a war. This time England must be shunted out of the picture early—just as Belgium was in the last war. The quickest and surest way to do it is by air. Germany's vest-pocket Navy is no match for Britain's might on the sea. Her army could never make a landing on British soil. But her air force, with high explosive, gas bombs and all forms of chemical warfare, might be able to stop Britain in her tracks before the English ground and sea forces could go into action.

Let us imagine that overnight Germany should decide to put the British out of any possible play. Her best bet would be a monster air raid on the main centers—London, Birmingham, Chatham, the naval base, Southampton, Dover and many other points of industrial strength—but mainly, of course, London. Here the raiders could sever the many cables of communication and the mighty seat of government—the point of power that

controls the vast empire. Blotting out London with either high explosive or chemicals would have such a monstrous reaction, would be such a grim stroke at the morale of the nation, that it would take months to reorganize the intricate mechanism and put the nation back on its feet as an offensive power in a European conflict.

To do this, Germany naturally would have to employ ships capable of a wide cruising area and the carrying of great loads. These planes would require large crews to handle all the intricate duties necessary in a mission of this kind. There would be two pilots, one navigation officer, one bombardier officer in charge of the bombing details, and at least two men to act as gunners in the defense.

A close examination of the available craft suitable for such a raid discloses that the famous Dornier Super-Wal four-engined flying boat would be the most likely choice. It has a wide cruising range, and is very seaworthy. With four 500-h.p. Jupiter VIII motors, (British, by the way) the Super-Wal has a top speed of 136 m.p.h. and carries a disposable load of 15,840 lbs. Imagine what a formation of twenty such ships could do, assuming they got through the London defenses!

Their equipment includes full night-flying instruments, two-way radio, a navigation compartment comparable to that in any Atlantic liner, and fuel tanks accommodating more than 1,000 gallons. Allowing a few hundred pounds for special armament in the way of high-caliber guns and modern air cannons, these ships could still deposit three-quarters of a ton of destruction and make a fast getaway.

The question naturally arises—what has England to offer in the way of defense against this type of raider?

The only thing worth mentioning, even with the vast improvement in all forms of anti-aircraft guns, is the modern interceptor. On this month's cover, we have shown the form of defense employed by the British fighter squadrons using the Hawker Super-Fury fighter. Squadrons of these machines have been posted around the London defense area, and Britain believes that in them she has the answer to the air raid problem.

However, of all military machines, the interceptor fighter is probably the least understood, especially in countries where such a ship is not included in the air defense system. The Hawker Super-Fury, with the Rolls Royce "Goshawk" steam-cooled engine, is the most efficient type of interceptor in the world today. It has a top speed of 250 m.p.h. and is the fastest service machine in the world. Contrary to general impression, it is not a ship that can only get upstairs fast, and be confined to a small radius of action. Not at all! It climbs to 20,000 feet in about seven minutes, to be sure, but it can stay in the air well over two hours. It carries two Vickers guns of the new high-speed type, and is the safest bet in the swiftly forming defense against enemy raiders.

Thus, if a war should break out, you can bet your last dollar that Britain's first line of defense would not be her Navy, but her air service. The Hawker-Fury pilots of the London defense area would have to take up the work where old No. 39 Squadron, Home Defense, left off in 1918, in the last attempted raid on London. On that memorable occasion, they destroyed seven Gothas out of eleven that had crossed the British Coastline. What would be the record now?



The peacetime war against insect life, as carried on by the Army Air Corps. Here you see an Army bomber spraying the tropical swamps of Panama with Paris Green to rid them of the deadly malarial mosquito.

Official Photograph, U. S. Army Air Corps

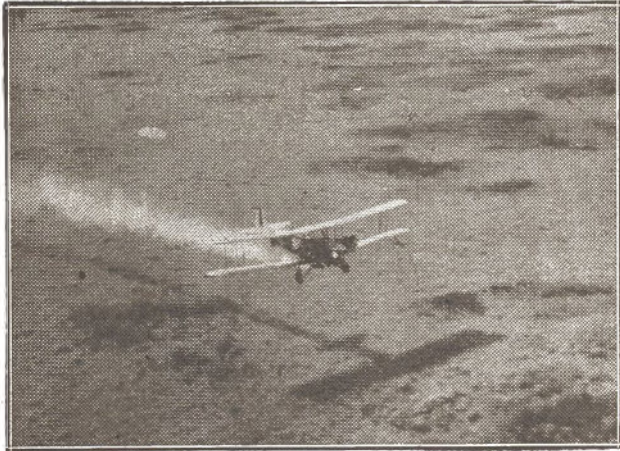

And here's another use for the peacetime war plane—one of Uncle Sam's pilots flying low over a cotton field in the South, releasing a chemical compound that does away with the destructive boll weevil.

Official Photograph, U. S. Army Air Corps



# Calling All Planes!

## WHAT THE ARMY AIR CORPS DOES IN PEACETIME EMERGENCIES

By Colin Kerr Cameron

Author of "Don Quixotes of the Air," "Sky Insignia of Army Airmen," etc.

**T**ROUBLE and emergencies just naturally compel people to call upon the Army Air Corps for help. What kind of trouble it is, doesn't seem to make any difference. People seem to think that Uncle Sam's flyers can be relied upon to put to rights anything that lies outside of normalcy. Storms, floods, tornadoes, and those things called "acts of God" by the insurance companies—all of these things, most people believe, can be adjusted by the Army Air Corps. And usually they are right!

One day last winter, there came a buzz on the tele-

---

There's so much talk of Army fighters and bombers these days that we are apt to lose track of what those same Army ships have as their constant duty in peacetime. Dropping food instead of torpedoes, real eggs instead of bombs, killing insects, mapping unknown areas, saving lives—these are only a few of the routine duties of the Army Air Corps in times of peace. People think Uncle Sam's airmen can fix everything—floods, storms, tornadoes—and usually they are right!

---

phone in the Operations Shack at March Field, California.

"Say, lieutenant," boomed a heavy voice into the ear of the officer on watch, "I'm up here at Las Vegas, Nevada, and there's some folks about a hundred and twenty miles north in a hell of a predicament!"

"Well, what of that? What do you want us to do about it?"

"If you can't do anything, nobody else can!"

"Okay, don't get excited. Let's hear the story."

(Continued on page 74)

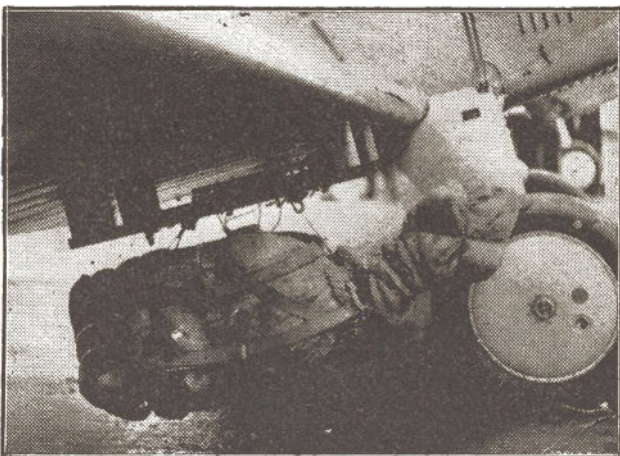

Official Photograph, U. S. Army Air Corps

That's a bomb rack—but no bomb! It's an outboard motor to be dropped to needy sufferers stranded in flooded areas. Such service was of untold value back in 1929, when thousands of people were made homeless by the Mississippi flood.

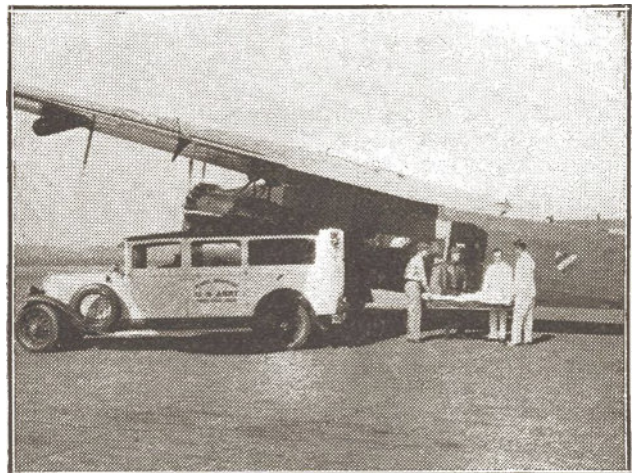

Official Photograph, U. S. Army Air Corps

And here's the well-known air ambulance—an Army Air Corps plane equipped as a mercy ship, with flight surgeon, attendants, stretcher, and everything needed to rush desperate cases to medical aid.

# The Griffon's Gamble

KERRY KEEN—  
SKY SLEUTH—  
SOLVES A NEW  
MYSTERY

\*\*\*

A SLEEK-WINGED amphibian swept out of the east with a low roar of its Avia W-44 motor and raced toward the gleaming lights that shone from Southampton to the east shore of Long Island. The pilot had left a secret hangar a few miles south of Montauk Light half an hour before. Since then, he had made a survey of the surface vessels below and then, suddenly checking the time by the wristwatch under the sleeve of his black evening cloak, he had turned toward the shore line with a nod to the man in the back seat.

Without a word, they changed seats, and the man in the evening clothes snapped the black enameled swivels of the parachute harness to the Dorsal pack fitted to the back cushion of the comfortable chair.

Then, as the black amphibian eased toward the shore, the new pilot drew back a steel handle. Suddenly the giant 1,000-h.p. Avia ceased its roar, and only the low whine of slipstream emerged from under the eighteen-cylinder power plant. The Skoda mufflers had been cut in.

The strange ship climbed gently, for the motor was still ramming out its revs. Below was visible a vast black area that meant well-trimmed lawn. In the center, at the top of a semi-circular driveway that wound its half-moon path through patches of heavy and expensive foliage, stood their goal—Rockwell Manor, the palatial mansion of the Long Island Prances.

It was the annual midsummer dinner and ball, staged annually by Hubert L. Prance, internationally known millionaire and oil operator. Already the lights of expensive cars were streaking up that driveway. At the long private dock, facing the cool, gray-blue ocean, a few palatial cruisers were warping in, with uniformed men in attendance. At a buoy, a few yards off the bathing float, bobbed a gleaming, silver-hulled flying boat that was worth a king's ransom.

Little did they know—these scions of fortune, these butterflies of society, these kings and dictators of finance—that they were gathering for the opening tableau of a tragedy that was to shock the nation.

More cars rolled up and uniformed chauffeurs opened doors and bowed their charges out. Footmen and butlers in scarlet and braid announced the arrivals. Soft music floated through the reception room, and already members of the younger set were gliding over the polished teakwood floor of Rockwell Manor's famed ballroom.

Overhead purred the silenced motor of a black amphibian. A man in black evening clothes had climbed out of the sheltered coupé top and stood poised on the wing-root. He nodded to the pilot and dropped.

The ship pulled away and climbed. The pilot circled



Illustrated by C. B. Mayshark

easily and watched the black parachute drop silently toward the flat roof of the residence below. Several minutes passed; then he saw the reassuring beam of a signal lamp that flashed three times. He nodded and drew away from the area, checking the watch on the dashboard carefully.

"Four minutes to go," he breathed.

The man who had taken this daring leap landed on Rockwell Manor with delicacy and accuracy and worked fast, once he had cleared himself of the black parachute harness. He hurriedly rolled the black silk canopy up into a ball and darted to a ventilator that opened on the roof-top. He stuffed the bundle in quickly, and hid behind a massive old chimney.

Something popped lightly, and the man in the black evening coat stuck an opera topper on his head at a jaunty angle. Then he pulled a scarlet mask from his pocket and placed it over his eyes. A third object was drawn from below his opera cloak—a box.

He edged to the buttress of the roof, threw a long leg over and found a hidden iron pipe partially covered with vines. Carefully, with the string of the box in his teeth, he lowered himself to where he could place his toe on a wide window-sill. Moving like a cat, he felt carefully for the window.

# THRILLING "KERRY KEEN" AIR NOVELETTE

By Arch Whitehouse

Author of "Guns of the Griffon," "Without Benefit of Tracer," etc.

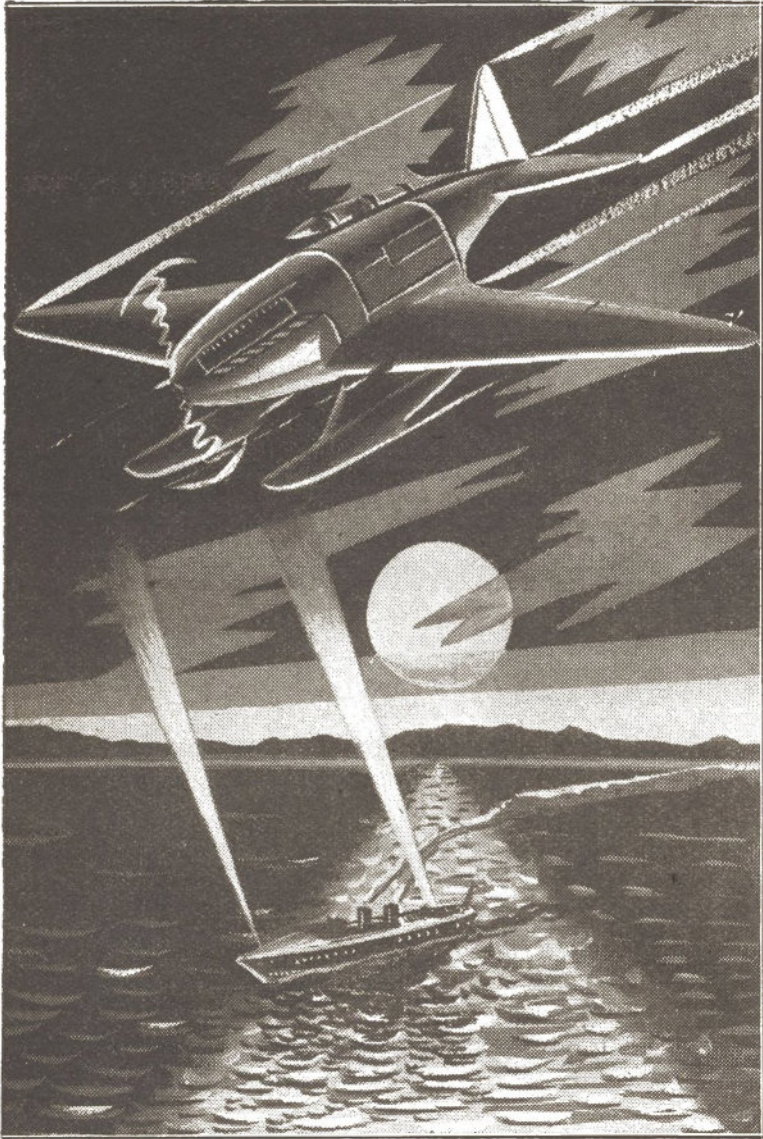

Directing his full fire into the Dornier's tail, Kerry Keen charged in toward that armored ship.

**I**NSIDE he could see a tall, sparse man in black and gleaming linen. He stood behind a large mahogany desk, his fingers holding a black package before his eyes. The window eased up in well fitted guides and the man behind the desk whirled. He stared into the small black hole that seemed to blink out of an automatic pistol. The package in his hands dropped to the table with a thud.

The man in the scarlet mask glided to the table, picked up the black package and replaced it with the one he had carried in his teeth.

"What do you want?" Prance gasped, starting to reach for a desk phone.

"Stop!" ordered the man in the scarlet mask. "Hands away from that phone—yes, and the button. This gun might go off, you know."

"Well, you've robbed me. What are you waiting for?"

"I want the rest—the leases."

"The leases? Who are you?" Prance muttered.

The man in the evening cloak and scarlet mask smiled. He drew a small card from his waistcoat pocket and flipped it across the desk. Prance picked it up and stared at it.

Gleaming white yachts bobbed in the Sound in front of that gaily lighted mansion. Glittering, streamlined cars sped up the driveway, and the soft strains of music floated out into the night. Little did those kings of finance know that they were gathering—not for their dictator's annual ball—but for the opening tableau of a tragedy that would shock the world. For in a plane high above that gay scene, flew a man in a black cloak and scarlet mask. The dread Griffon was to be an uninvited guest at the festivities—and his presence could mean only one thing—death!

✱ ✱ ✱

"The Griffon!" he said, his voice dropping to an awed whisper.

The man opposite smiled. "The Griffon," he said.

Prance sat down in his large chair, and jerked when the man in the scarlet mask took a step forward.

"Keep your hands on top of your desk. Mr. Prance. That's it. What about the leases?"

"You're too late. Yung Shi Pai has them. I turned them over ten minutes ago. He just left this room. Why don't you go after him and get them?"

"I'm not that sort of fool," smiled the Griffon. "No, you are the victim this time, Mr. Prance. You have double-crossed your syndicate—and your country. You must pay the penalty. You see, I know about your dealings with the Manchukuo Petroleum Corporation."

"How the devil? How do you know, Mr.—Mr.—" blurted out Prance.

"Simple. I have hounded Yung Shi Pai ever since he arrived. Interesting, these Mongols who are working with the Japs in Manchuria. Interesting devils, but bad medicine, if you give them an inch. You, Mr. Prance, have given Yung Shi Pai entirely too much rope.

I'm sorry it had to happen this evening, but there you are. It will mess up this splendid party of yours, won't it?"

"Are you going to murder me in cold blood?" Prance asked faintly.

"Murder you? Certainly not! The Griffon is accused of many things, but they'll never get him for murder, Mr. Prance. Besides, there are so many other, more interesting ways—in that package I brought, for instance. Open it."

Prance opened the square, paper-wrapped package, staring at the Griffon with terrified eyes. Under the wrapping was a beautiful carved box of Oriental design. Prance's jaw dropped. He knew, then, that his end was near.

"Go on," the Griffon taunted him. "You required a lot of nerve on the leases. This should be easy."

Prance's fingers slipped the catch back and the lid came up. Three gleaming knives, set in carved ivory handles, with blades that glinted and flaunted their keenness, lay in three depressions. Scarlet silk formed an ominous background for the blades.

(Continued on page 56)

# Lives of the Aces in Pictures

## XXXVIII—Carl Bolle, Last Leader of the Jagdstaffel Boelcke



1—Carl Bolle began his military career in the cavalry, and later transferred to the air service. In the fall of 1916, he was flying a two-seater when he was attacked by several Allied single-seaters. They wounded him several times and finally forced his plane down, but Bolle, after dragging his observer from the plane, made his own lines.

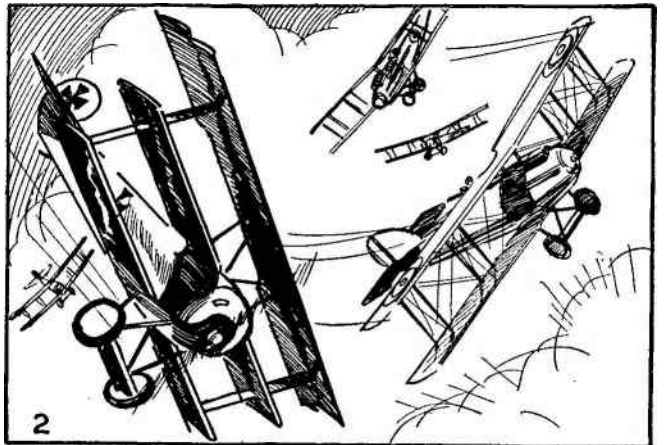

2—In February, 1918, after a long convalescence, Bolle, although not yet an ace, was chosen as the logical leader of the Jagdstaffel Boelcke. Bolle led his men against some D.H. raiders. The formation was broken up and Bolle found himself alone among the enemy ships. However, he succeeded in making a dive to take him to safety.

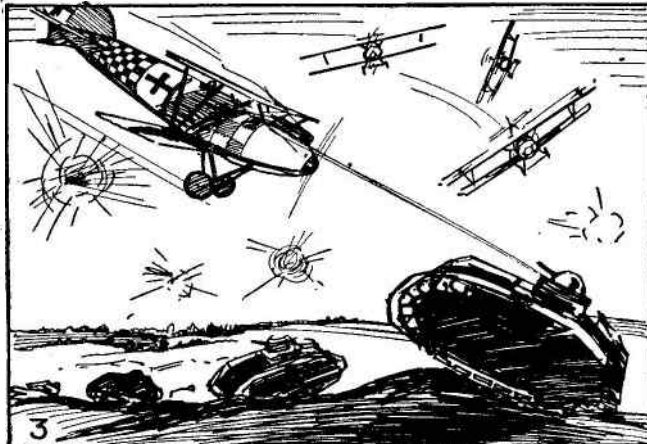

3—During the Anglo-French counter-offensive, Bolle led his *Staffel* to drive off the quantities of Allied planes which were scouting to protect the Allied ground forces during the drive. Then Bolle turned his attention to the Allied tanks. On one occasion, he swooped down on them and kept his machine guns blazing until three of the tanks were set on fire.

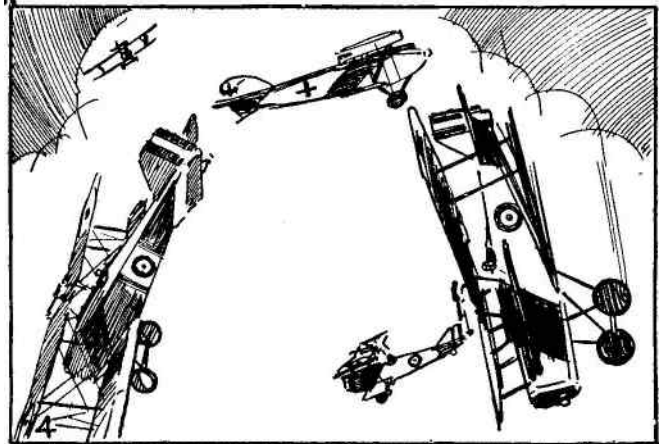

4—The *Staffel* had kept up the traditions of their beloved leader, Boelcke, under Bolle, whose clean fighting gained him his enemies' admiration. November 1, 1918, they met a group of S.E.5's. As usual, Bolle was foremost in an attack which downed five of the Britishers.

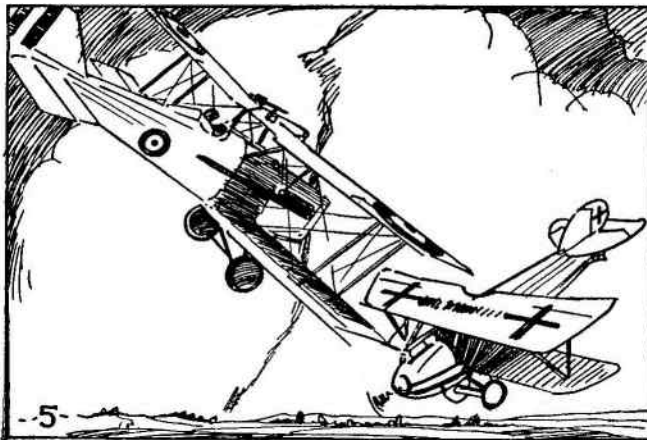

5—In the last fight of the squadron, three days later, their effort was valiant despite the German army's collapse. During two patrols they were credited with six enemy planes shot down. Four of these Bolle himself downed in a last desperate effort to overcome great odds and uphold the German air force's honor.

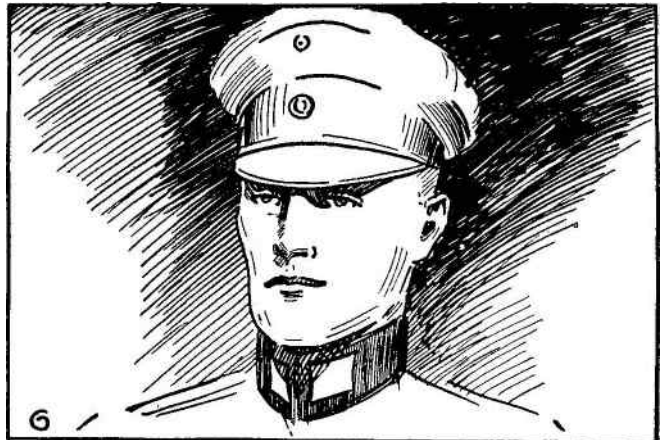

6—Carl Bolle was educated at Oxford, where his love of sports won him many friends among his later enemies. His total score was thirty-six planes destroyed, most of which were credited to him after he became *Staffel* leader. After the war, he continued his aviation activities in Germany in many different capacities.

# Suicide Spandaus

WAR-FLYING YARN

By Orlando Rigoni

Author of "The Scarlet Scourge,"  
"The Seven-Shot Ace," etc.

High above that gray strip of hell bounded by a trench that held grim men in khaki and a trench that held grim men in field-gray, Captain Stokes, of the 16th, led his flight—to break the great Boche blockade over Void. But the 16th never reached the skies above Void. Straight into a trap they were led—a trap where the blood-red eyes of stuttering Spandaus dripped tears of death.

\*\*\*

THE canteen was fogged with tobacco smoke. The men's faces at the wine-smeared tables showed white and tense through the drifting haze. Over in the corner nearest the smoking stove, Lieutenant "Blab" Booth raised his drawling voice in song.

Blab had been born with a smile on his lean, freckled face. His pale blue eyes held a bit of a gleam that was humor and a bit of gleam that said, "Be careful."

The men of the 16th, stationed near the old winery at Vezelesi, had named him Blab with affectionate regard for his prolific stories. He bragged about everything. He bragged about his home town in Texas. He bragged about his horses and about his family. He bragged about everything but his personal prowess, and about his twelve victories he said nothing at all.



Stokes flung his Spad like a catapult straight through that suddenly born hell.

If pressed for details of his air fights, he'd just shrug his shoulders and grin. "I just up an' shot him," he would say.

Lieutenant "Baldy" Rivers squirmed in his seat at the center table in the room. He leaned his smooth pate close to the tight-lipped, gray face of Captain Stokes, who was the leader of the 16th.

"Blab's at it again," Baldy said in a hushed voice. Perhaps it was the words of Blab's song that made Baldy talk in such awed tones.

Captain Stokes rubbed his wide back against the broken chair. "It won't hurt a man to sing, Baldy. Let him get it out of his system."

Blab's voice wailed across the room singing a parody on an old cowboy song:

*(Continued on page 64)*

# War Planes Album

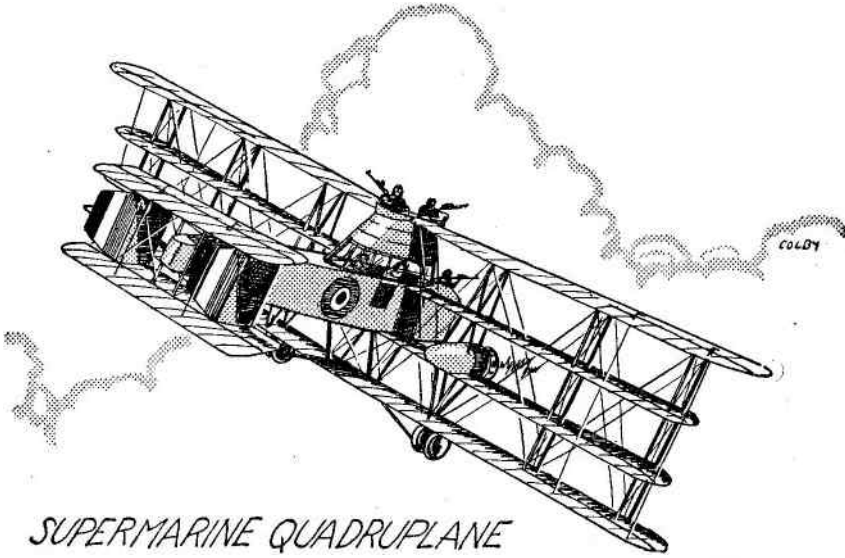

*SUPERMARINE QUADRUPLANE*

## THE SUPERMARINE QUADRUPLANE

**T**ODAY, collectors of war-time aviation photos have dubbed this aerial monstrosity the Wing-Walker's Nightmare, with the realization, of course, that any modern air-circus acrobat would stand a good chance of losing his way in his effort to do the rounds of the wing tips.

As far as we can make out, this ship came out late in the war under

such hush-hush conditions that it was not discovered by the general public until several years later. We offer it, not as an actual fighting craft that saw service over the lines but as a representative model of what was going on in those dizzy days of 1918.

The ship was built in secret by the Supermarine Aviation Works, Ltd., of Southampton. This firm is now in the hands of Vickers, Ltd., and has mended its ways considerably. From

general appearances, it appears that the company had a lot of old struts, wings, wheels and wire to use up before the war ended, and this was the result.

It was actually a quadruplane, as will be seen from a built-up turret clambering up from the top of the fuselage to the upper surface of the top wing, where a regulation Scarrf mounting was fitted. We assume that there was a platform below for the gunner to stand on, with his feet completely blocking off the view of the pilot. Another gunner was placed in the nose of the fuselage, and a bomber officer had office space somewhere in between.

The lower wing was set about three feet under the lower longerons. The second wing was fitted directly to the lower longerons, and the third bolted to the upper. The fourth—well, go ahead and figure it out for yourself. There was a complete closed-cockpit which looked suspiciously like grandpa's greenhouse. The motive power used was two Cosmos "Mercury" engines of 350 h.p. each, fitted in streamlined nacelles that were carried on steel struts just above the upper surface of the second wing.

The tail surfaces were of the biplane type, with elevators on each tail-plane. We have no record of its speed or performance. Do you care?

## 1914 BREGUET

**T**HIS unusual ship is one of three constructed by the old Louis Breguet firm for military work, in 1914. The other two included a two-seater hydroplane and the A.G. 4 armored ship, of which we can learn little. The interesting feature of this 1914 ship is that it was an all-steel job, as far as the general structure was concerned, and the manufacturers took great pains to explain that the undercarriage was equipped with "Oleopneumatic" shock absorbers and spring suspension.

At any rate, this ship was originally designed for the Military Trials of that year, but the outbreak of the war in August, 1914, brought all the actual military trial business they were looking for. Some of these ships made up France's first line of aerial defense.

The ship was a wide-winged biplane with a monocoque fuselage slung midway between upper and lower plane. The lower wing was in two parts, and joined the general structure at the undercarriage struts. The undercarriage carried four wheels, but no skids, and was braced back to an inverted-Vee pylon fitted under the rear cockpit, which carried the tailskid. You wonder how they

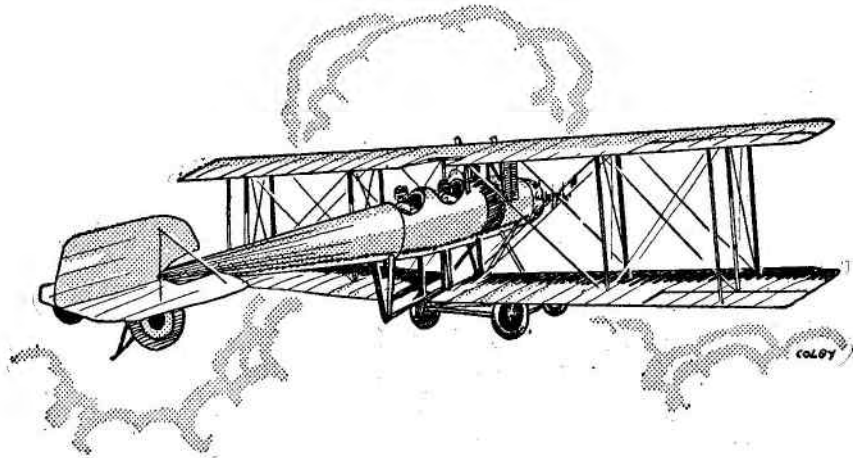

*1914 BREGUET*

landed that baby.

The tail assembly was a ghastly arrangement of stabilizers, fins and rudders that seemed to be held on by nothing but the control wires. The narrow chord fin extended above and below the fuselage, and from a close inspection, appeared to turn with the rudder—a balanced rudder arrangement.

The motor used was the 140-h.p. Canton-Unne, a water-cooled power plant of which we know little except

that it was the forerunner of the line later known as the Salmsons. It was a water-cooled radial, and the radiators may be seen on each side of the fuselage under the leading edge of the upper wing.

There was no set armament on this machine, of course. In the early days, the observers carried carbines and, later, automatic rifles and even shotguns, while the pilot, if he dared take one hand off the controls, went into action with a large automatic pistol.

No, we aren't crazy! The ships illustrated here were actually built—and flown—during the World War. Designers of every period have let themselves go occasionally, and gone in for the unusual. Here you see four aeronautical nightmares, the Supermarine Quadruplane, the 1914 Breguet, the Siemens and Halske and the Voisin Triplane.

#### THE SIEMENS & HALSKE FIGHTER

**T**HIS German single-seater came out at the end of the war, and while it is not as startling in design as the Supermarine, it has features that in 1918 were far ahead of their time and must have made many a German pilot's eyes water. Today, it looks somewhat modern.

This machine did not see service. It was freakish mainly in its power plant which, while being a rotary, also had radial characteristics. The cylinders rotated at 900 r.p.m., and the crankshaft rotated in the opposite direction at the same speed. Thus, the actual engine speed was 1,800 r.p.m., but the prop was ticking at 900 r.p.m. and they were getting 1,800 r.p.m. in power. Natty and neat, but somewhat complicated.

Owing to this feature, they could use a smaller four-bladed prop and get a shorter length to the undercarriage. These gave the ship a squat appearance. A stubby fuselage also added to this illusion. The wings were of the biplane type with a splayed Vee-type inter-plane strut. The center-section was carried on a splayed N-strut, and there was considerable stagger in the arrangement.

The Siemens & Halske ship, with its own power-plant, climbed to 7,800

feet in three minutes, if we are to believe the German figures. Its forward speed has not been recorded in the information we have. The fuselage was built of plywood, and the stabilizer and fins were integral with the body. Little outside bracing was used. The mounting of the balance rudder is interesting.

Two synchronized guns were carried, firing through the propeller, as well as all the usual war-time equipment.

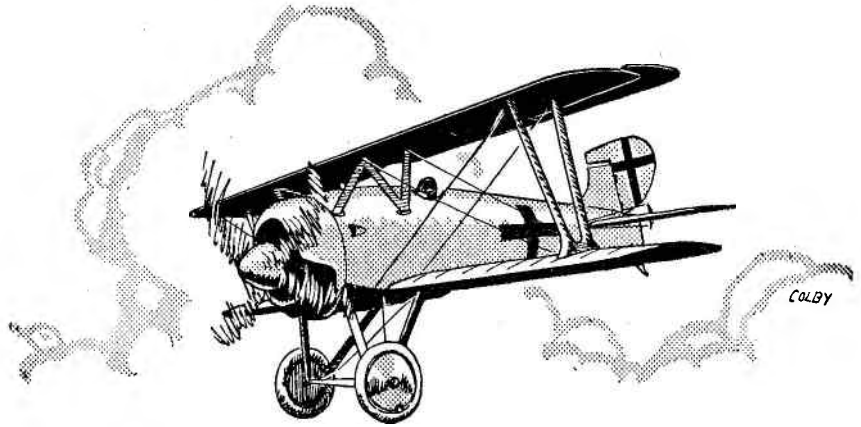

SIEMENS & HALSKE

To return to the climbing ability of this ship, its most unusual point, we find that it was obtained by a high-pitch prop of four blades rotating at comparative low speeds. Actually, according to figures we have checked since, it climbed to 26,000 feet in twelve minutes. Thus, without realizing it, the Siemens & Halske people built the first real interceptor plane. Of course, it could not have had a high forward speed without modern controllable-pitch props.

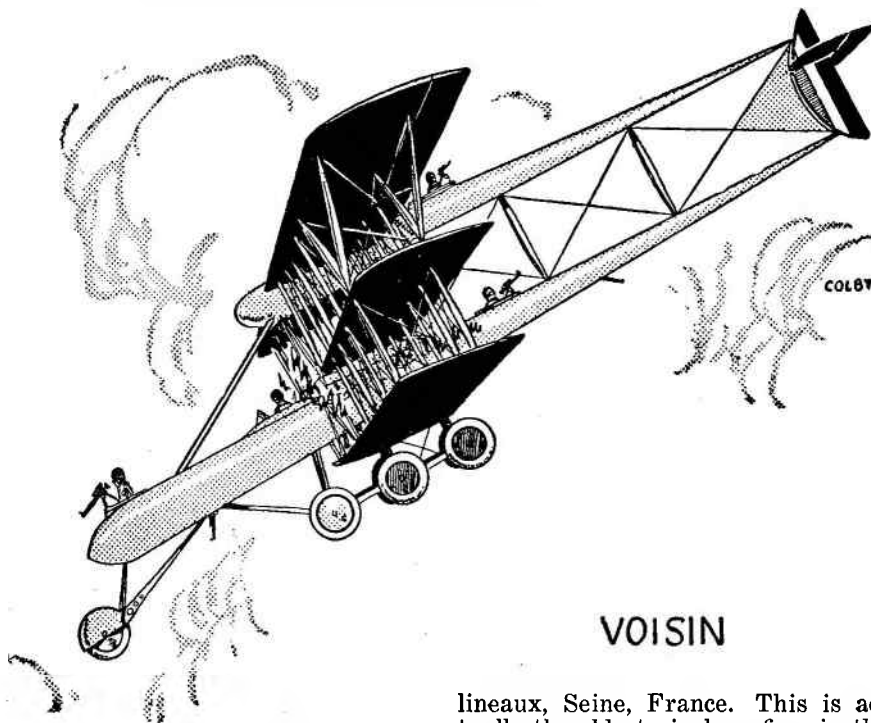

VOISIN TRIPLANE

VOISIN

**T**HE Voisin machines, many of which flew under the French tricolor during the war, were manufactured by the Aeroplanes Voisin, Boulevard Gambetta, Issy-les-Mou-

lineaux, Seine, France. This is actually the oldest airplane firm in the world, having been organized by the Voisin Brothers in 1905.

The company saw the ups and downs of aviation throughout the early 1900's, and had begun to get somewhere with their flying school and small factory by the time the

war broke out in 1914. From the start of the big conflict, the company seemed to aim at large ships and develop a fine folding wing device. Their big effort came in 1918 when they brought out a startling triplane.

This machine was a veritable flying fortress. It carried no less than five distinct gun turrets. There was one in the nose; one high behind the top plane in the second-story fuselage; two to fire through the floor of the main fuselage, and one behind the main planes in the upper part of the main fuselage. Four 220-horsepower Hispano Suiza engines were mounted on the middle plane—two as tractors and two as pushers. They gave it a speed of something around 110 miles an hour.

The startling part of the ship is the extra fuselage mounted from below the top plane to the top of the fin. This was a slender affair, carrying a gunner's turret up near the wing, wired and strutted to the top of the lower fuselage.

The 1918 Voisin triplane was 23 meters long. Its span was 32 meters and the chord 2.4 meters. A remarkable undercarriage system involved a front wheel well ahead of the nose of the ship and then a 6-wheeled arrangement beneath the main portion of the body.

# HAPPY LANDINGS

BY ARCH WHITEHOUSE



## What of An Independent Air Force Today?

There has been much talk in the United States about unification of the various branches of the Air Service, but little has ever been done about it. Here's a new idea from Washington which, as Arch Whitehouse points out, has a strong resemblance to the war-time Independent Air Force, that group of daredevil pilots from many nations. Let him tell you about it, and about other phases of aviation. In this department, FLYING ACES gives Mr. Whitehouse free rein to express his own personal views.



FOR years the subject of the unification of the Army and Navy Air Services has been brought up, but somehow it has never got anywhere. However, General Douglas McArthur, Chief of Staff, who determines the moves of the Army, has hit upon an idea which at first sounded new, but which we of the old war days, upon careful consideration, recognize as a revival of the old Independent Air Force.

Some of you will probably remember that during the last year or so of the war, the British hit upon the idea of organizing the Independent Air Force, a mobile grouping of crack squadrons which could be shifted quickly from one front to another. In general, it included all pilots and observers who were cracks in their line. Some would go so far as to say "cracked," for of all the wild organizations, charged with patriotic fervor and enthusiasm, there has never been anything quite like the old I.A.F. It was composed mostly of R.F.C. squadrons and men, but a few smart American outfits or, at least, a few crack American airmen, were included when the work suited. There were a few Frenchmen and one or two Belgians in it, also.

In other words, if you were air-crazy, formation-dizzy or looking for a new form of suicide, you either applied for the I.A.F. or they sent you there to cool off. Their duties included special trench and road-strafting, long-distance—and how long!—bombing raids, spy-dropping, retrieving shows and all the odd suicide flights the Staff could think up. But what a record the I.A.F. ran up!

Today, we see the same idea in the new General Headquarters Air Force, which is being formed for the provision of "a force of great mobility and striking power, ready to meet a threat from any direction."

This new group will consist mainly of combat units of the Air Corps, together with certain observation and service units. The whole body will eventually consist of 1,000 pursuit, attack and bombing planes. The orders for new equipment will bring the numbers up within a few months. Thus, this broad organization will be in the hands of Corps commanders of the Army, and the Chief of Air Corps will be relieved of practically everything but schools, depots, training, organization and equipment problems.

While there appears no chance for unification of the two services, this initial set-up seems to be leading toward the next best thing. In an emergency, the same groups connected with the Navy might be taken over by this General Headquarters Air Force, and would

double its strength. Not a bad idea, at that.

### THE COMMERCIAL COMET

WE get new shocks every day. Only a short time ago, we were agreeing that the De Havilland Comet, which won the England-to-Australia race, was nothing but a freak ship built directly for the winning of that race. It was a flying gas-tank with no real commercial value.

Now we learn that the French "Air France" commercial organization has ordered several of them for the new South Atlantic mail runs to South America.

Jean Mermoz, chief pilot of Air France, has stated in no unmistakable terms that he thinks the new Comet is the answer to their mail-contract worries. It would be able to span the South Atlantic between dawn and dusk, he points out, whereas flying boats take a day and a night.

"I would rather take my chance on a ship of the Comet type," he stated, "which can fly well on one engine, than risk a landing in mid-ocean with the best flying boat made."

He explained that no flying boat yet made can withstand the buffeting of sea in an Atlantic storm. In contrast, the Comet is so fast that it could out-run any storm, and with its range of 3,100 miles and its rare speed, its pilot would be facing less of the elements in a short-time flight than he would if he were trying to fight it out with a heavy flying boat.

Mermoz has made several trans-Atlantic flights and should know what he is talking about. Incidentally, the Comet recently broke all speed records between London and Paris, clipping plenty of time from Frank Hawk's old mark.

### MR. MULLIGAN

IN answer to the hundreds of letters I have been getting concerning Ben Howard's new high wing monoplane, I feel that I ought to give the information in this department, hoping that it will catch the eye of many.

In the first place, there is nothing secret, strange or unusual about the ship—except its name. Actually, it is a commercial job, but is also considered a long-distance racing machine fitted. A 500-h.p. Pratt and Whitney "Wasp" is said to give it a top speed of 312 m.p.h. A special N.A.C.A. cowling is used over this motor, which is also fitted with a 14:1 supercharger, indicating that

(Continued on page 45)



# From Racer to Fighter

## THE NORTHROP FIGHTERS.

SHOWING HOW RACING SHIPS MAY BECOME BASIC TYPES FOR HIGH-SPEED FIGHTING PLANES. NORTHROP TAKES A BIG LEAD IN THE MILITARY AVIATION FIELD.

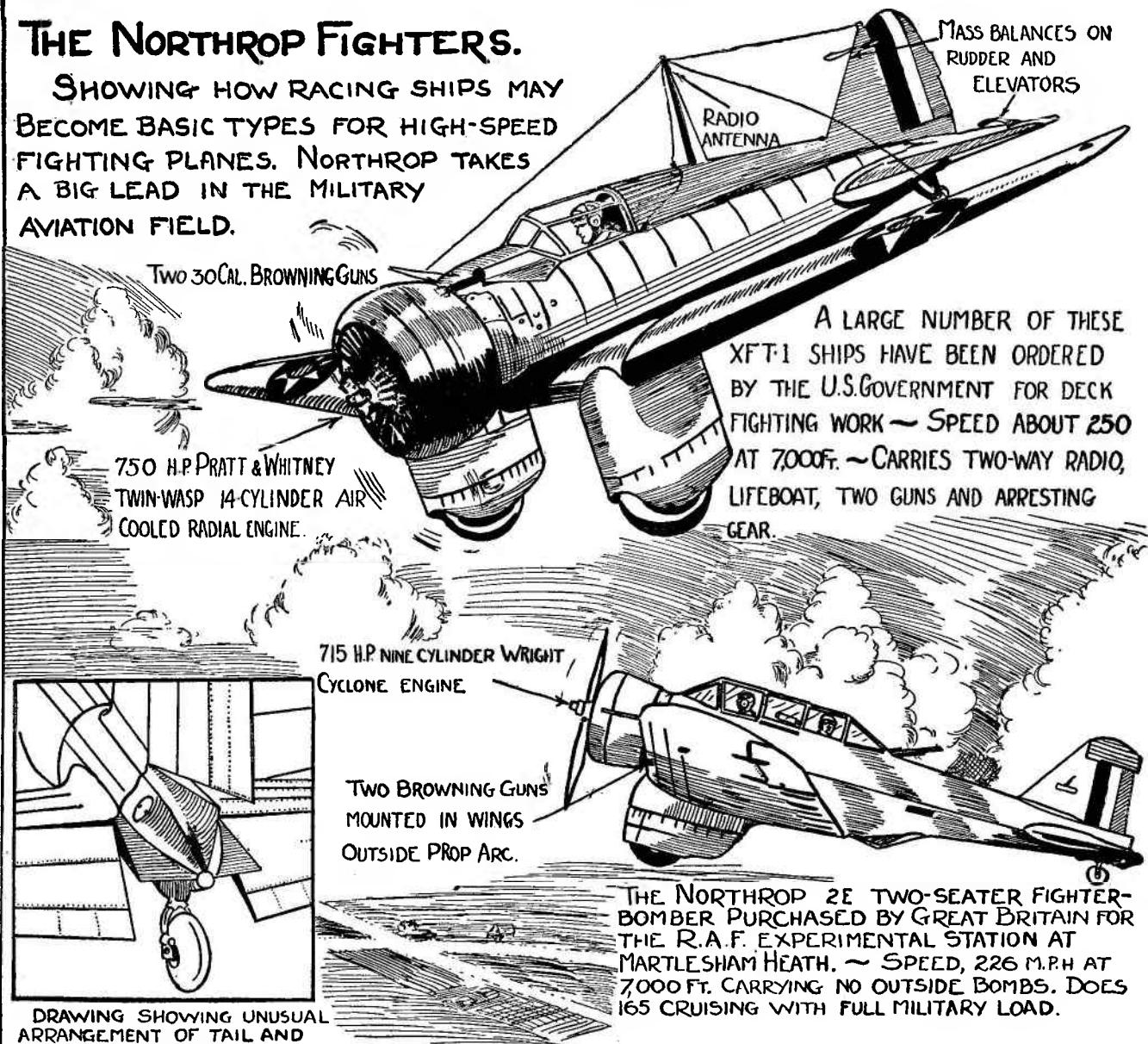

A LARGE NUMBER OF THESE XFT-1 SHIPS HAVE BEEN ORDERED BY THE U.S. GOVERNMENT FOR DECK FIGHTING WORK ~ SPEED ABOUT 250 AT 7000 FT. ~ CARRIES TWO-WAY RADIO, LIFEBOAT, TWO GUNS AND ARRESTING GEAR.

TWO BROWNING GUNS MOUNTED IN WINGS OUTSIDE PROP ARC.

THE NORTHROP 2E TWO-SEATER FIGHTER-BOMBER PURCHASED BY GREAT BRITAIN FOR THE R.A.F. EXPERIMENTAL STATION AT MARTLESHAM HEATH. ~ SPEED, 226 M.P.H AT 7,000 FT. CARRYING NO OUTSIDE BOMBS. DOES 165 CRUISING WITH FULL MILITARY LOAD.

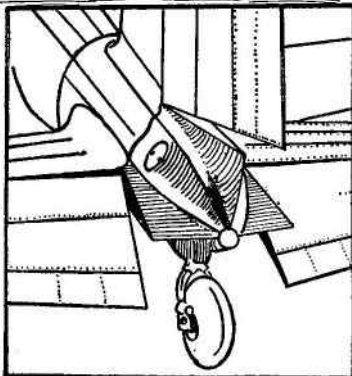

DRAWING SHOWING UNUSUAL ARRANGEMENT OF TAIL AND CONTROL ASSEMBLY OF 2E SHIP.

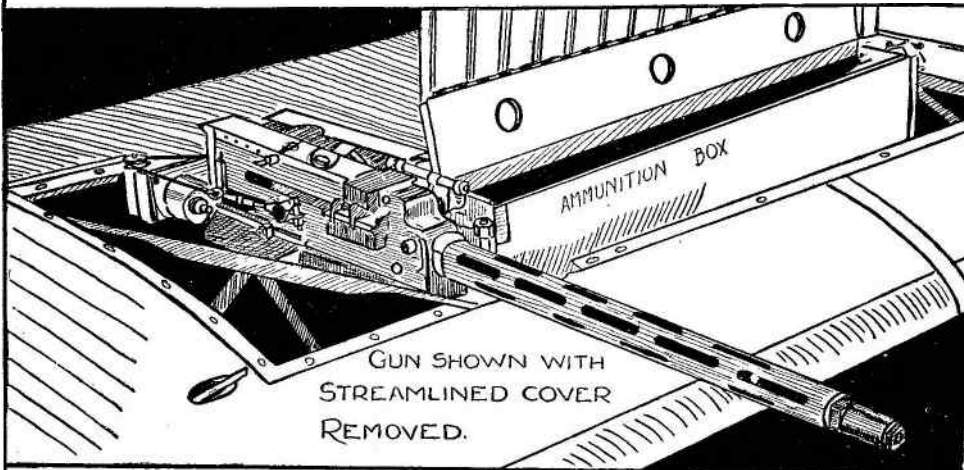

GUN SHOWN WITH STREAMLINED COVER REMOVED.

THIS DRAWING WAS MADE FROM ONE OF A NUMBER OF PHOTOGRAPHS WHICH RECENTLY APPEARED IN "DEUTSCHE FLUGILLUSTRIERTE" A GERMAN AERO WEEKLY. IT SHOWS IN FULL DETAIL THE WING GUN MOUNTING OF AN AMERICAN TWO-SEATER FIGHTER WHICH IS SUPPOSED TO BE ON THE SECRET LIST. COMPLETE DETAILS OF THE OBSERVER'S COCKPIT, HIS GUNS AND BOMB RELEASING DEVICES WERE ALSO SHOWN ~ NOT THAT IT MATTERS BUT AMERICAN READERS MIGHT BE INTERESTED IN WHAT THEY ARE PAYING FOR IN THE WAY OF AERIAL DEFENCE, TOO.

35 Arch WHITEHOUSE

WHY AMERICAN AVIATION MAGAZINE EDITORS GO MAD ~



# WISECRACK-UPS



Taxi in on this runway and pick up a plane load of laughs! In this department, we present a collection of jokes, cartoons, and humorous verse. For all original contributions which we can use here, FLYING ACES will pay \$1. No contributions will be returned unless a stamped, self-addressed envelope is enclosed.



"You old meanie, Bill! You didn't tell me you could fly!"

### A CLOUDY ONE

*First darky* (during the war): Ah thinks Ah'll join the infantry.

*Second darky*: Ah ain't. Ah's goin' to be a flyer.

*First darky*: Yeah? And when the white folks says, "Niggah, git out an' crank!"—where are yo' goin' to stand?

### MAYBE WE'RE WRONG

*Reporter*: How did you frighten off the enemy planes?

*War ace*: I was so mad I was beside myself.

*Reporter*: Yes?

*Ace*: And they thought it was a two-seater.

### GOING TOO FAR

*Replacement*: How far is it to the 31st Squadron?

*Doughboy*: In the direction you're going, they don't call them squadrons—they call 'em Jagdstaffels.

### FAST AND LOOSE

*Curious onlooker* (rushing up to a crack-up on the flying field): What's the matter—loose controls?

*Greaseball*: Nope—tight pilot.

### SAVED BY A HARE

*Mechanic* (after forced landing): My rabbit's foot is certainly lucky, all right. Before the motor conked and we were forced down, I couldn't find it. Now that we're on terra firma, I've found it again.

*Pilot*: Yeah? Where did you find it?

*Mechanic*: Stuck in the gas feed line.

### HOPE SPRINGS ETERNAL

*Pilot*: Did you hear about my last flight?

*Bored*: I hope so.

*Dumb Dora* thinks that aviators are the only ones who have any ups and downs in life.

### PAJAMA PARTY

*Ack emma* (knocking on door of Pinkham's shack): We just found a crack-up, and we thought it was you.

*Pinkham*: That so? Did the guy wear a pair of pajamas under his suit?

*Ack emma*: Well, come to think about it, he didn't.

*Pinkham*: Then it wasn't me. Haw-w-w-w!

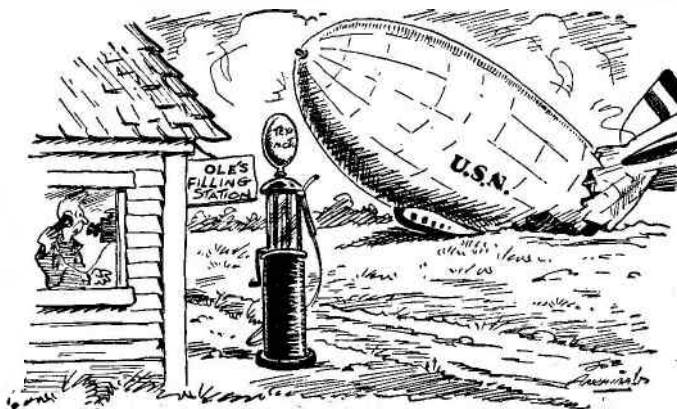

"Daily Bugle? Give me the lost and found department."



"How are the Giants doing?"

### JUST A CLEANER-UPPER

*Small boy* (seeing his first autogiro): What's that, pop?

*The old man*: Why, that's a skyscraper, son.

### BREAKING IT GENTLY

*Flyer* (rushing into hangar after a bad crack-up): Do you do repairing here?

*Mechanic* (after brief look at fallen plane): Yeah, but we don't do manufacturing.

### JUST TIRED

*Smart*: How can you say he's lazy?

*Aleck*: How can I say it? Listen, he's so lazy that when the pilot told him to bail out, he said, "Let it sink—I can swim."

### A MARATHON ACE

*Flying fan*: Where's Jimmie this afternoon?

*Second ditto*: If he can fly like he says he can, he's flying, but if he flies like I think he can, he's walking.

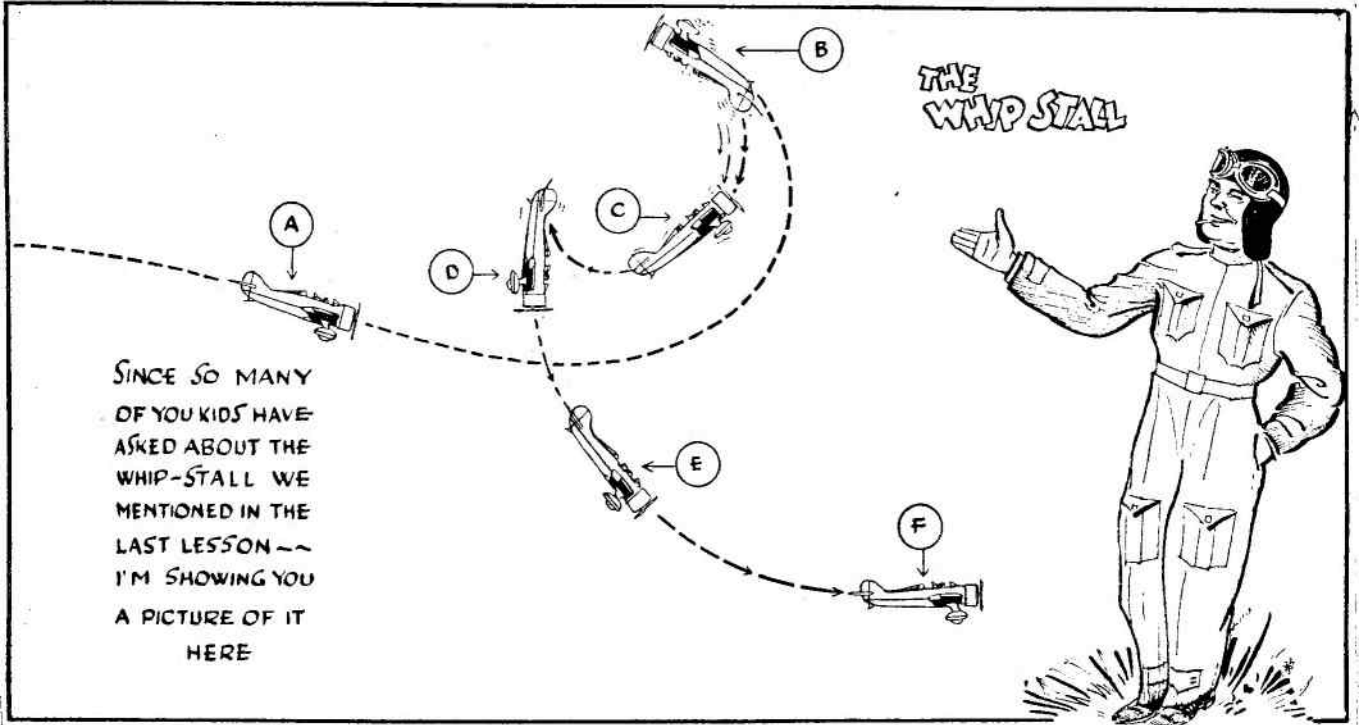

SINCE SO MANY OF YOU KIDS HAVE ASKED ABOUT THE WHIP-STALL WE MENTIONED IN THE LAST LESSON -- I'M SHOWING YOU A PICTURE OF IT HERE

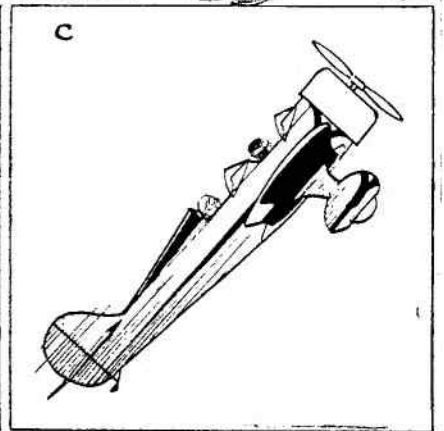
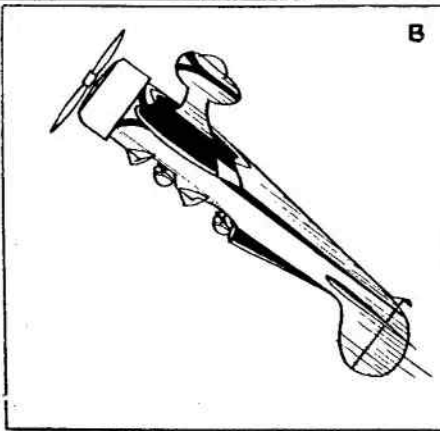
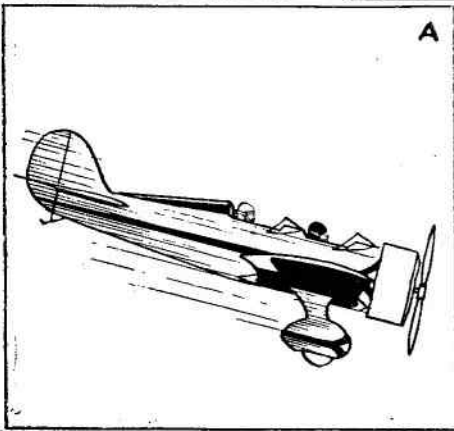

It usually happens just before the break in a loop—when you haven't enough power and speed to take you on over the arc.

Up there at position B, the ship loses flying speed and falls back tail-first, providing the rudder is neutral and wings are laterally level.

She starts flying backwards and down hill, a cute little trick all her own, because your stick is well back, the tail flies up and her nose goes down.

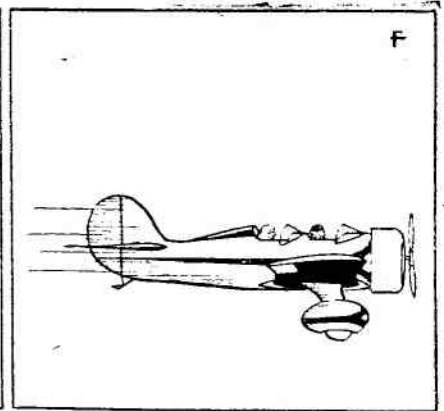
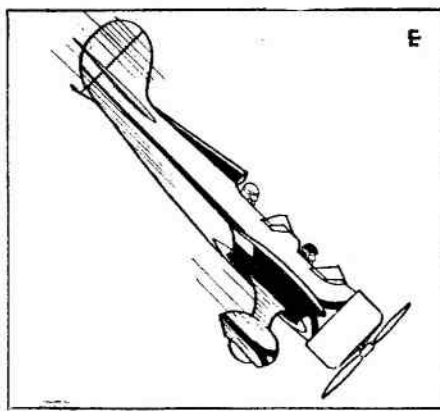
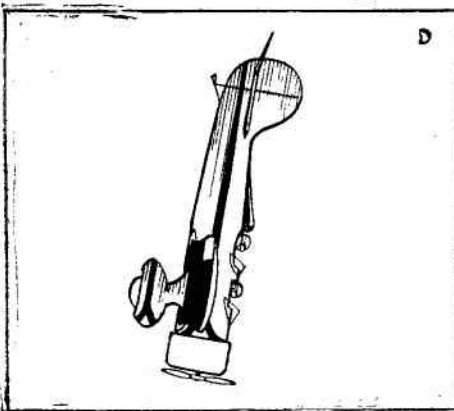

And at this point, her tail flies up and her nose goes down, and she changes from goin' to comin' in the twinkle of an eye. Here you swing onto the safety belt.

And before you know what happened, she's a-flyin' as normal as a perfect lady, an' if you're not nursin' a busted bill, you're wonderin' if you ain't had a bad dream.

Airplanes aren't designed to withstand the whip stall, so if you see you can't pull over the top of a loop, hang a wing down and slip out from the side. It's easier on the bridge work.

# Here and There in the Air

In this department, FLYING ACES presents some of the odds and ends of aviation—interesting facts about flyers and their foibles, news picked out of the sky here and there. We hope you like it.

## PILOTOPICS

By ROY HUMPHRIES



1—THE FLYING CO-ED, RUTH PRUSS, NEW YORK, FLIES TO AND FROM SCHOOL DAILY . . .



2—PILOT LEAVES GROUND WITHOUT PLANE! UPON FINDING A DEADLY FER-DE-LANCE SNAKE IN HIS PARACHUTE

Roy-Humphries



3—A SEAPLANE CAN TAKE OFF ON ROUGH WATER EASIER THAN ON CALM WATER . . .

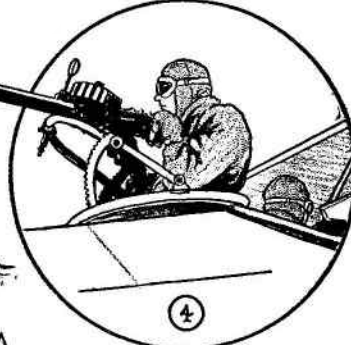

4—A BULLET BEGINS TO FALL AS SOON AS IT LEAVES THE GUN, YET IT WILL HIT A BULL'S EYE.

### Stories Back of the Above Pictures

1—Miss Ruth Pruss, of Brooklyn, N. Y., flies daily from Floyd Bennett Airport in that city to Garden City, Long Island, to attend classes at Adelphi College, a distance of about twenty miles.

2—During the recent Army maneuvers in the Panama Canal Department, Captain W. J. Davies, a member of the 6th Composite group, Air Corps, was a bit nonplussed one morning to find a deadly fer-de-lance snake coiled up in his parachute. The captain went several feet off the ground without his plane, and needless to say, made a safe landing without the chute.

3—It is much easier for a seaplane to take off on a rough sea than on a calm surface because the bobbing momentum of the choppy waves gives greater lifting power to the ship.

4—The motion of a bullet traveling horizontally does not interfere with the operation of gravity. Gravity acts on such a bullet precisely the same way that it acts on a bullet dropped from the hand. A rifle or machine gun appears to shoot point-blank, or straight ahead, because the line of sight is above the bore and the center of the bore is pointed slightly upward.

### IT'S A BARGAIN!

AMERICAN air fares are the lowest in the world, according to figures received by the traffic department of Eastern Air Lines. The cost per mile to fly in the slower and older equipment of Europe averages eight to ten cents a mile. In this country, on the world's finest and fastest airplanes, which streak to the coast on four routes in 16 to 20 hours, from New York to Florida and New Orleans and from Chicago to Florida in eight hours, the per mile cost averages only five and seven-tenths cents a mile.

### FIRST WOMAN AIR TRAVELER

WITH her air mileage on the world's commercial airlines "somewhere between 250,000 and 300,000 miles," making her the No. 1 woman air traveler in the world, Mrs. James R. Leisk, wife of the chairman of Barclays, outstanding British bank, recently flew to Miami on Eastern Air Lines, on the last leg of an aerial vacation in Europe and this country, which will put 17,000 more air miles under her feet before returning to her home in Johannesburg, Transvaal, South Africa.

"It's too bad they are not flying passengers across the South Atlantic yet," remarked Mrs. Leisk. "Then I wouldn't have to go to London by boat to fly to Africa."

"I think American airplanes, especially the Douglas, are simply marvelous, and for the life of me I don't understand why more American women do not use the airlines and why in heaven's name they object to their husbands flying. I've been told they do, you know."

Mr. Leisk is indirectly interested in Imperial Airways, British air transport system, which explains why Mrs. Leisk has flown so extensively.

### SPORT PLANES IN DEMAND

THE entire first group of the new Ryan S-T low-wing monoplane has been sold in advance of production—and that's an interesting record! Every effort is being made at the San Diego factory to meet the demand for this new type of sportsman pilot plane.

The Ryan S-T has attracted widespread interest as America's fastest sport plane for comparable horsepower. Its modern engineering includes an all-metal monocoque fuselage, air brakes or wing flaps, and Flettner tab controls replacing the conventional stabilizer. The Ryan company claims—with the 95-h.p. Menasco installation—a cruising and top speed of 120 and 140 m.p.h. respectively, and with the 125-h.p. installation, a cruising and top speed of 131 and 150 m.p.h.

# With the Model Builders

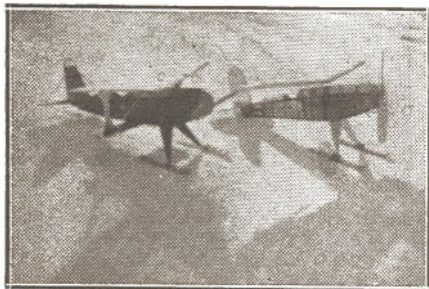

Just to show you what the model plans in FLYING ACES bring forth! At the left are two splendid models of the FLYING ACES Bi-plane and the FLYING ACES Sport Racer, built by Jack Herrick and Richard Herbers, of Detroit Lakes, Minn., from plans published in this magazine. And below is Benjamin Talsky's version of the FLYING ACES Cabin Plane, built from plans in last February's issue. Ben hails from Milwaukee, Wisconsin, and says he gets regular flights of 100 seconds from this model.



Julius Unrath, whose name is familiar to every FLYING ACES reader, built the interesting gasoline model pictured above. It's a six-footer, powered with a Loutrel Aero engine, and weighs 5 lbs. What's more, it flies 35 miles per hour, and has flown four minutes on three-sixteenths ounces of gas. Some high flyer!



Introducing A. Dudley Roberts, of Ceres, Calif., with one of his many models. This one is of bamboo construction, and when winder-wound, does better than a minute. Glides forty-five feet from a six-foot hand launch, and is a mean altitude-getter. Great work, Roberts!

Upper Right: Here's news from the first F.A.C. Squadron to be organized in Australia! This picture shows you members of the Squadron, with the Curtiss Hell Divers which they have built. The leader, H. M. Cameron, is the one marked by an X.



Lower Right: More Club members, this time from Houston, Texas. Reading left to right, Walter Thompson, with his F9C-2; Robert Mitchell, with his prize Fokker Tripe; and Alton Pruitt, holding a Newport 17. Their F.A.C. clubhouse is in the background.



Right: You all know the famous Boeing F4B4 by this time — or we're ashamed of you! Here's a model of this great ship built by John Bernet and his brother, of Shaker Heights, Ohio. This busy pair have been building models for three years.

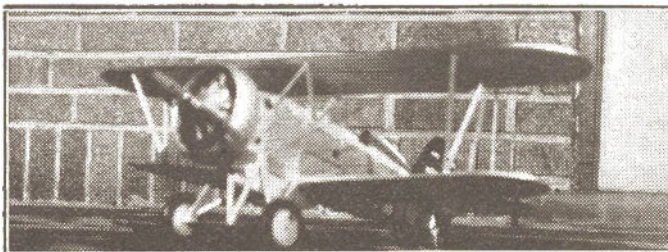

Left: A neat-looking model of the well-known Curtiss Goshawk, all marked up with Uncle Sam's Navy insignia. Its builder, Leslie Woods, Jr., of Little Rock, Ark., writes that he is an ardent F.A.C. fan.

Right: From far-off Honolulu, Hawaii, comes this picture of a Boeing P12F model built by Jack Yoshida, local leader of an F.A.C. Squadron. That's a mighty decorative model, Jack, and every F.A.C. in the United States is proud of you!

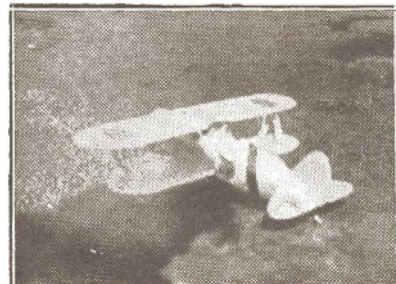

# Build the Martin Diving Bomber

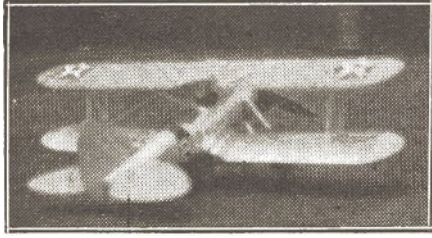

A close-up of the Martin Diving Bomber built from the plans shown here. If you want a ship that looks like this, go to it!

**T**HE Martin Diving Bomber, known in naval classification as the BM-1, is a two-seater job, powered with a 575-h.p. Pratt & Whitney Hornet. This ship was the first of its type capable of carrying a bomb weighing 1000 lbs. in a power dive to its terminal velocity, pulling out, and still remaining intact without dropping its bomb.

This bomber's armament consists of one fixed machine gun, synchronized with the engine to fire between the revs of the prop, and two flexible guns over the rear cockpit attached to a rotating mount. The rear pit, which contains an auxiliary set of controls, also provides for the installation of a wireless set. In peace time, the place of the bomb is used to carry a reserve tank, having a 60-gallon capacity, to increase the plane's cruising range.

The span of the top wing measures 41 ft. Its length is 28', 4 3/8" and height is 11', 6 1/4". Performance with 1000-lb. bomb is as follows:

Top speed at 6000 ft., 143 m.p.h.

Landing speed, 61 m.p.h.

Service ceiling, 15,000 ft.

Cruising range with extra tank, 525 miles.

A slightly modified version of this model, known as the BM-2, has a more powerful engine—the 620-h.p. Wright Cyclone—and, in addition, a ring cowl, consequently stepping up the ship's top speed to over 160 m.p.h.

The writers each built this bomber for the purpose of comparing notes on the flying characteristics of their respective models. After several tests were made, a comparison of their notes showed that practically all the items coincided. Suffice it to say that the flying scale model of the Martin Diving Bomber will climb steadily from an R.O.G. take-off, bank as gracefully as a seagull and land consistently on all "three."

A point we wish to bring to your attention at this time is the fact that many of you have become accustomed to the built-up type of fuselage, composed of bulkheads, formers and stringers. In recent months, the hollowed-out type of fuselage has become increasingly popular, and indications are that it will hold this esteem for quite a while. The hollowed-out type of construction is by no means difficult, and after reading the instructions, you'll

Service ships are in the news right now, so this month we present plans for one of the most interesting and spectacular — the Martin Diving Bomber, known in Naval classification as the Martin BM-1. Built according to the plans presented here, the Martin Diving Bomber will climb steadily from an R.O.G. take-off, bank as gracefully as a seagull, and consistently make three-point landings. In addition, you'll have a beautiful model of one of Uncle Sam's latest ships.

\*\*\*

By Jesse Davidson  
and  
Harry Appel

probably be sold on the idea. So let's pitch in right now.

## FUSELAGE

**T**WO blocks of balsa, each measuring 1" x 2 1/4" x 12 1/4", should be selected. The blocks should be very smooth and soft, as no other variety will do. They are then lightly cemented together, and the glue is spread only along the center lines of the blocks, both on top and bottom. The blocks should then be put under a weighted object to dry.

When they are thoroughly dry, you are ready to carve the fuselage form.

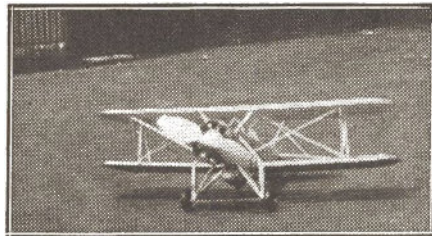

Note the arrangement of struts in this front view of the Martin Diving Bomber. These snapshots will help you in its construction.

Trace the outline of the top view of the fuselage on both top and bottom of the block and, with a sharp knife, cut to shape and finish by sanding with smooth sandpaper.

When this is done, trace the outlines of the side view of the body on both sides of the block, and repeat. Of course, you know it is first necessary to make patterns of the top and side view of the body in order to trace their outlines onto the block. A simple method is to trace the outlines direct from the drawings, transfer them onto stiff cardboard and cut out exactly on the line. Accuracy counts.

Plan No. 2 shows templates marked "A-A" to "D-D" from which other cardboard templates can be made. Each one

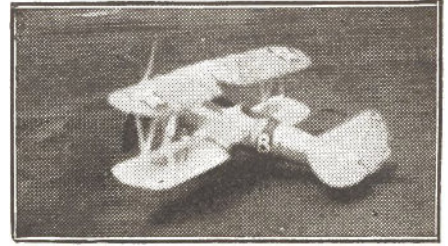

Another rear view of the bomber, showing clearly the two-seater construction.

is used to set up flush against the side of the fuselage at the positions marked as shown on the top view drawing. Hold the body up to the light, and if no light passes between the template and the outside wall of the rounded body, you have the correct shape. In other words, this method helps you to get both sides exactly alike.

After completing this, give the entire block a soaking coat of good banana oil. This will raise the grain a little. Allow time to dry thoroughly and finish by sanding the block smoothly again. Now split the block apart with a razor blade. Never use a knife.

Next, make another side view template of the inside of the fuselage which is 1/16" less all around except near the nose portion and tail end. By laying this flat against the inner sides of each half of the block and drawing its outline, you will have the area marked for the hollowing or gouging out.

Use a 3/8" gouge. This should be very sharp, as the ease of the job depends, of course, on the sharpness of the tool. Having a sharpening stone handy is a good idea, for it may be necessary to sharpen the tool every now and then. The walls are cut to a 1-16" thickness all around, starting from the point marked "B-B." The nose section is left thicker for added strength and forward weight. Do the job carefully and take your time. You'll get it done soon enough. By holding each hollowed half to a bright light, you will detect the thick spots, which you can cut down. Use smooth sandpaper and clean out well. Give a coat of banana oil to each half; then sand the roughness that may result.

Cut out balsa bulkheads shown on Plan No. 2. Note the direction of the grain. Use a harder type of balsa here. Take one-half of the body shell, mark the positions for each of the bulkheads, apply cement over the edges of each and set each one in proper place. When they are dry, apply cement to the outer edge, and also to the center lines of both halves, and press together firmly. Placing tight rubber bands at intervals along the body will help to hold them together until the glue has hardened. If you do a good job in joining the shells together, the center line will hardly be visible.

(Continued on page 78)

MARTIN DIVING BOMBER

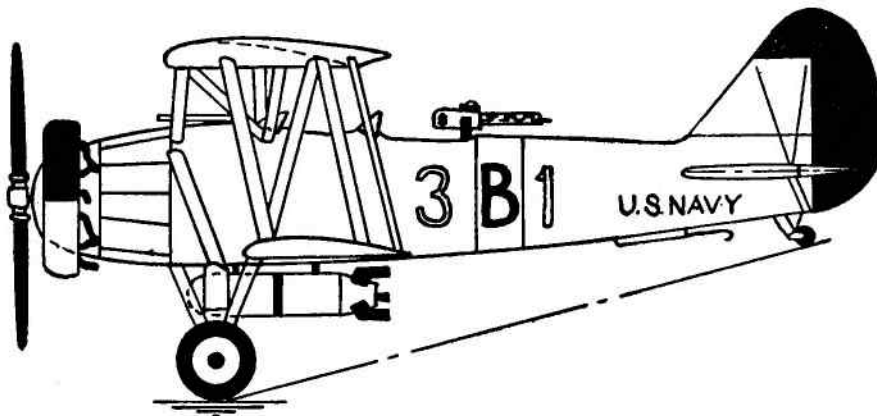

MARTIN 125  
U.S. NAVY DIVING BOMBER  
BM-2

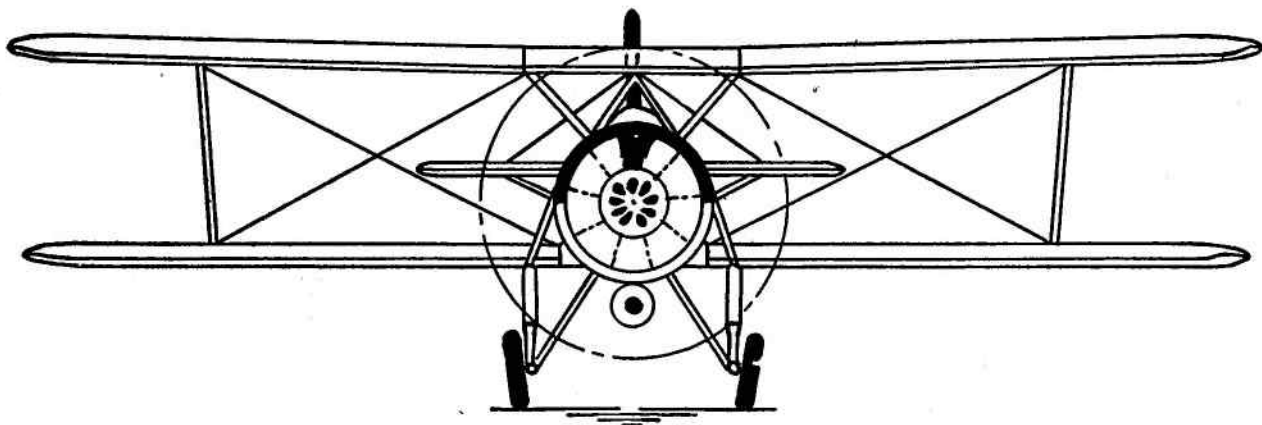
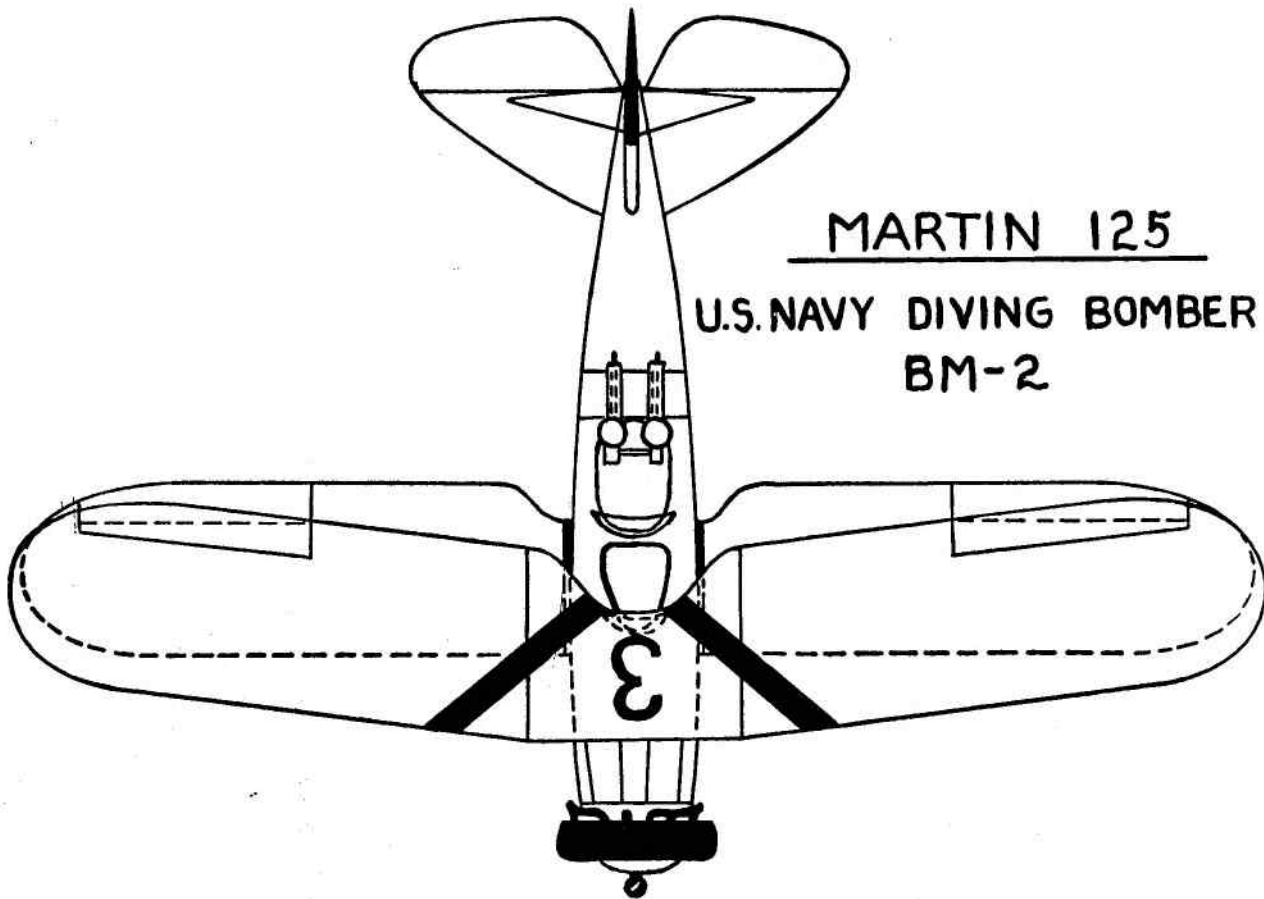

Jesse DAVIDSON 1935

MARTIN DIVING BOMBER—Plan 1

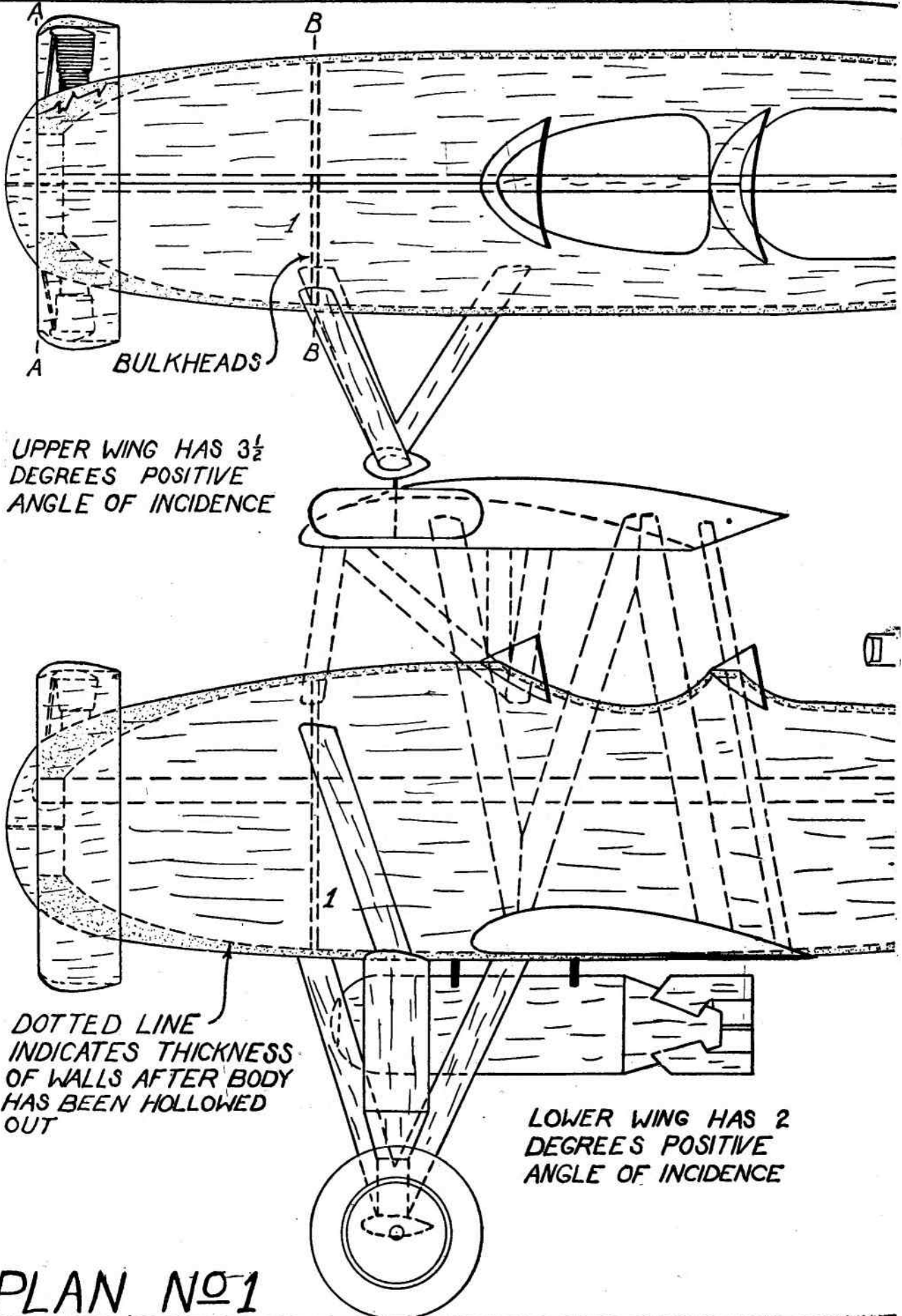

BULKHEADS

UPPER WING HAS  $3\frac{1}{2}$  DEGREES POSITIVE ANGLE OF INCIDENCE

DOTTED LINE INDICATES THICKNESS OF WALLS AFTER BODY HAS BEEN HOLLOWED OUT

LOWER WING HAS 2 DEGREES POSITIVE ANGLE OF INCIDENCE

PLAN NO 1



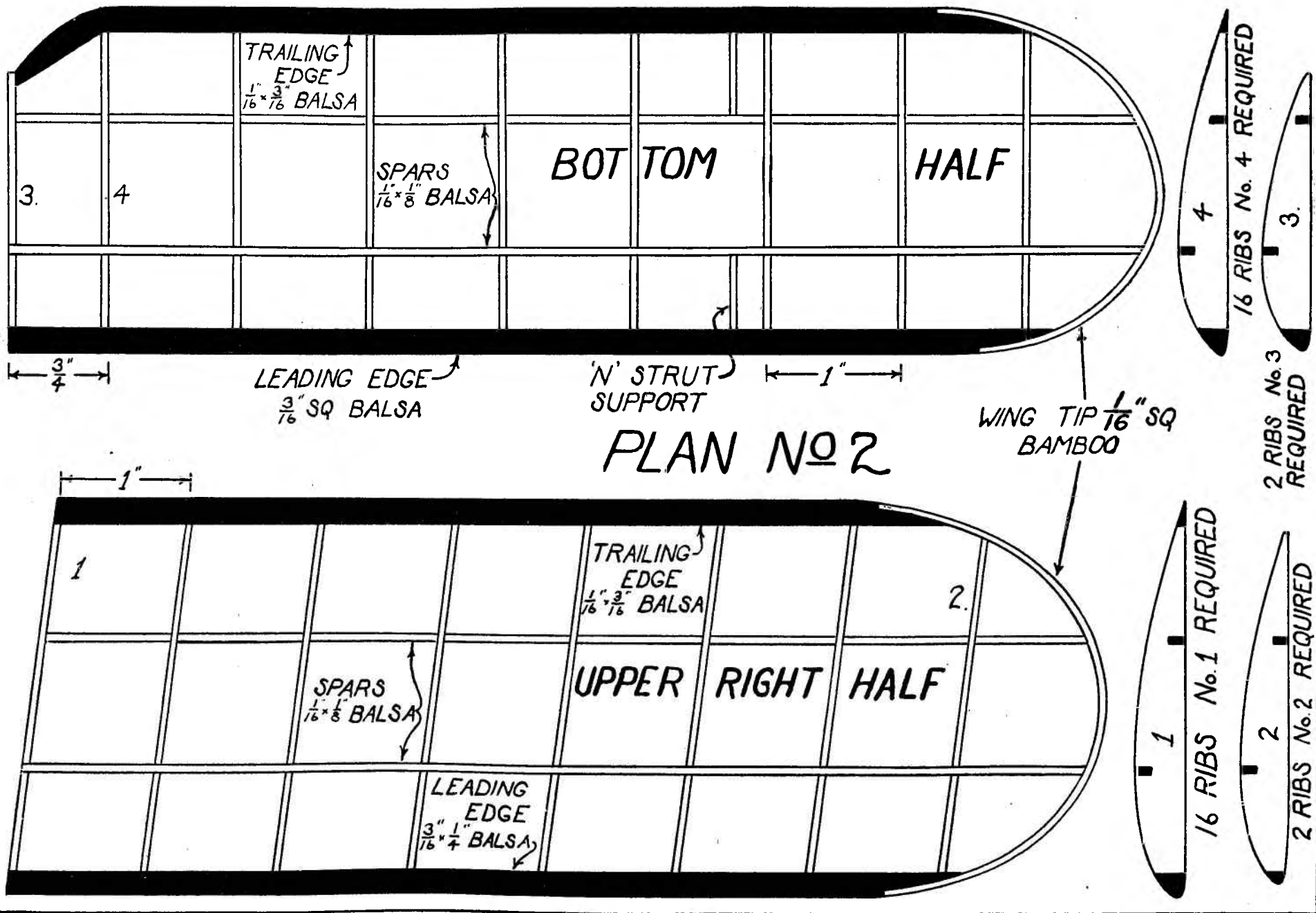

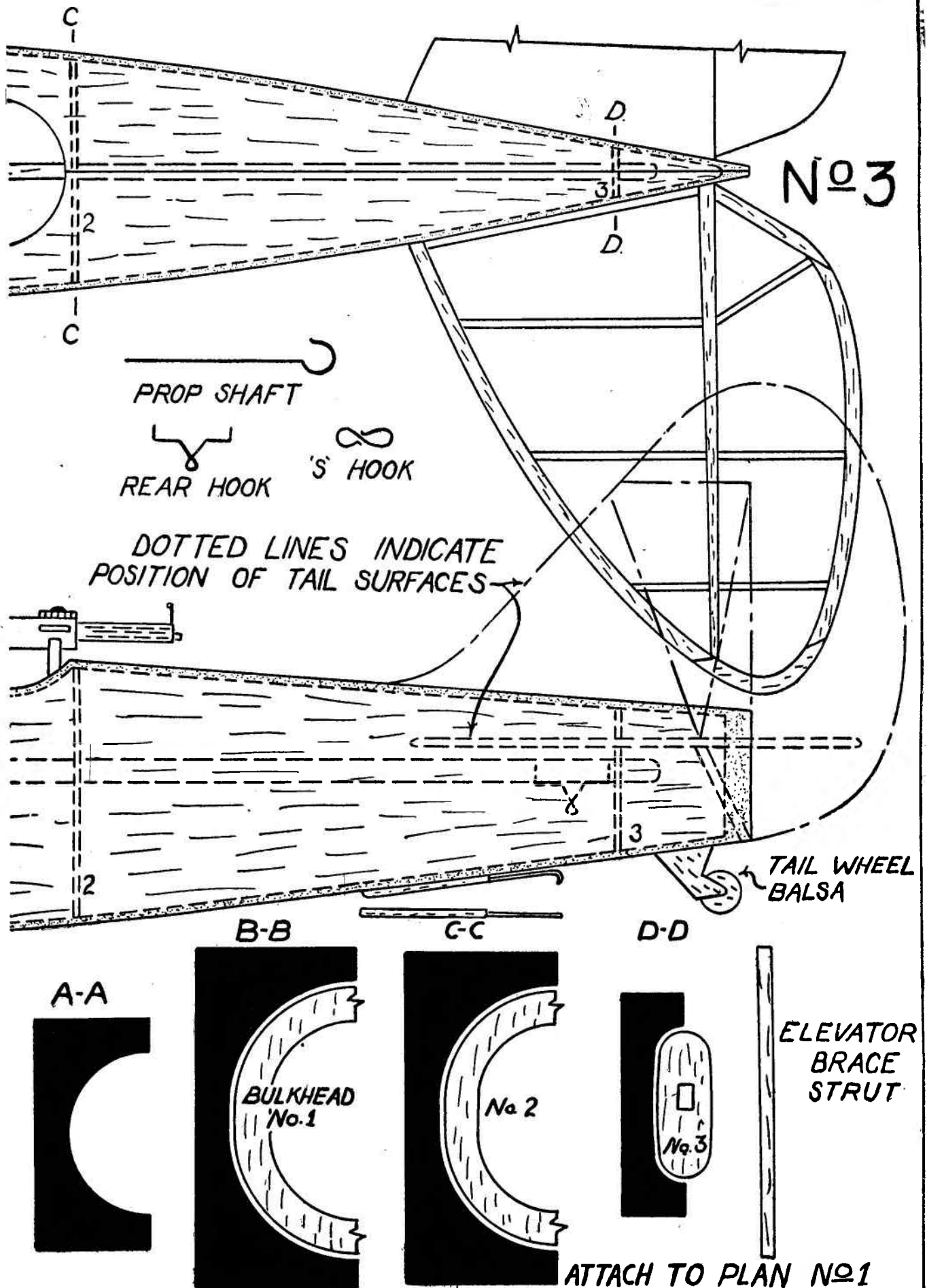

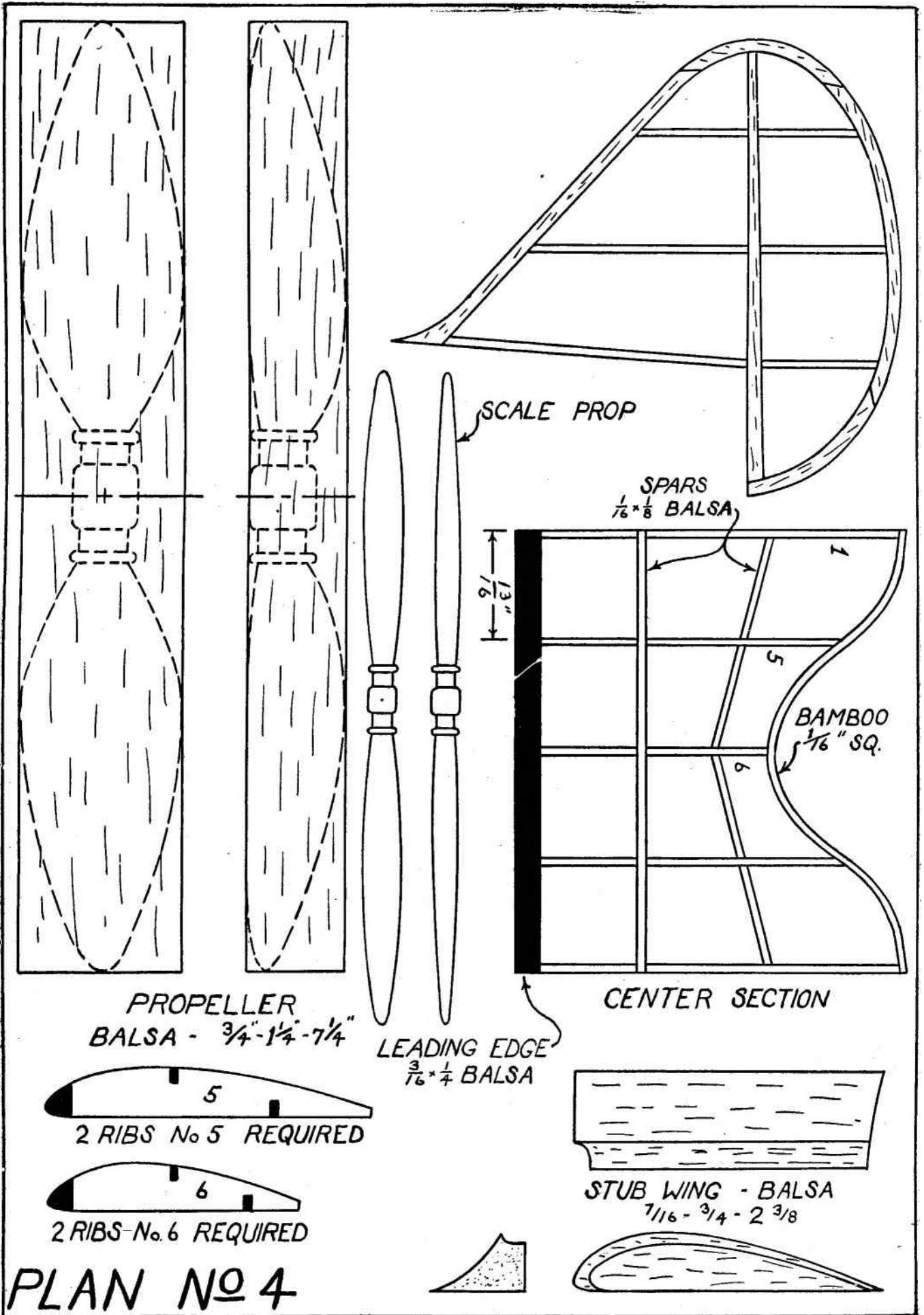

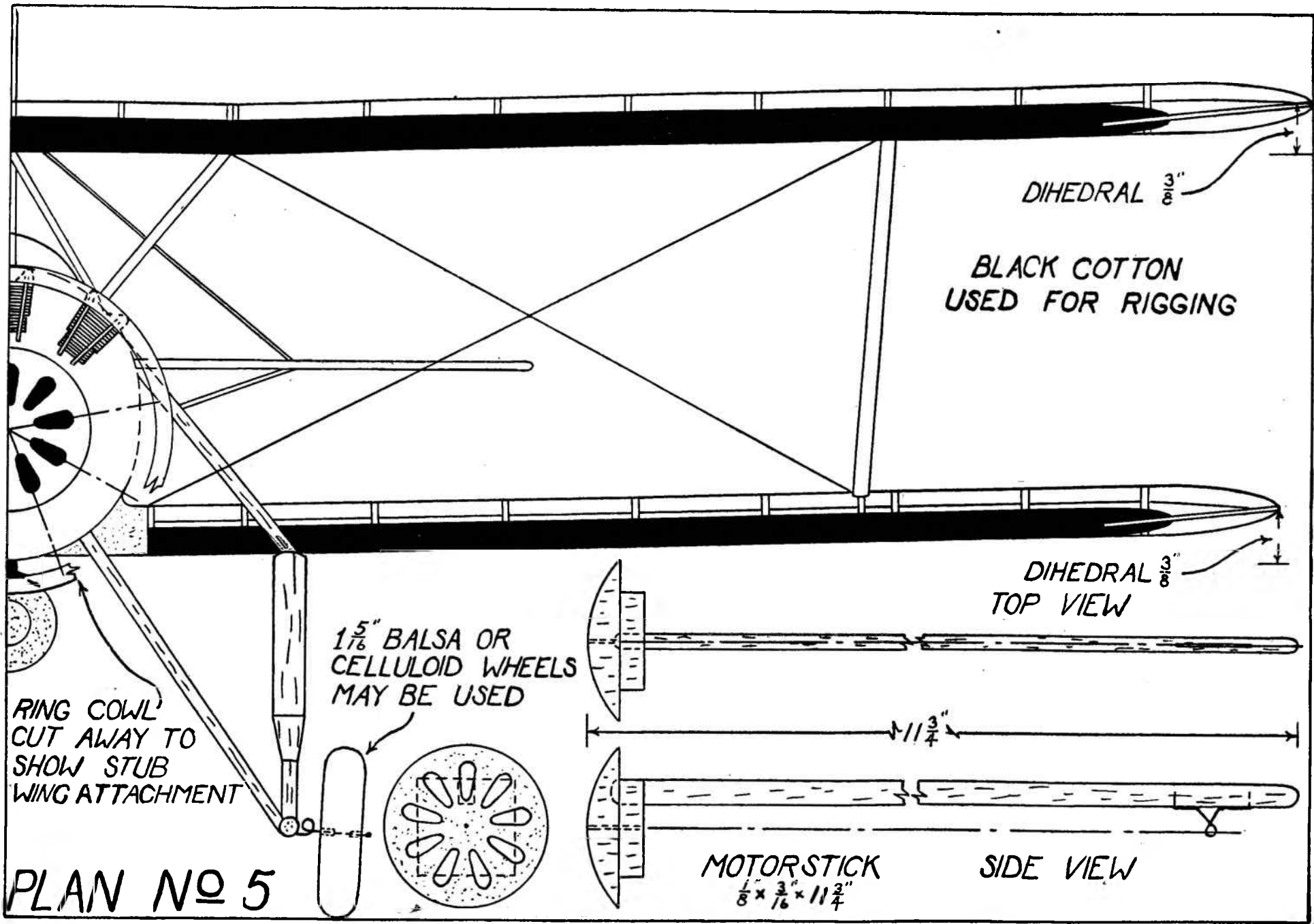

DIHEDRAL  $\frac{3}{8}$ "

BLACK COTTON  
USED FOR RIGGING

DIHEDRAL  $\frac{3}{8}$ "  
TOP VIEW

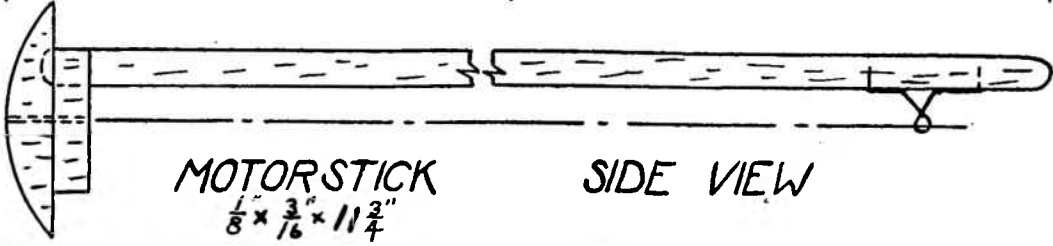
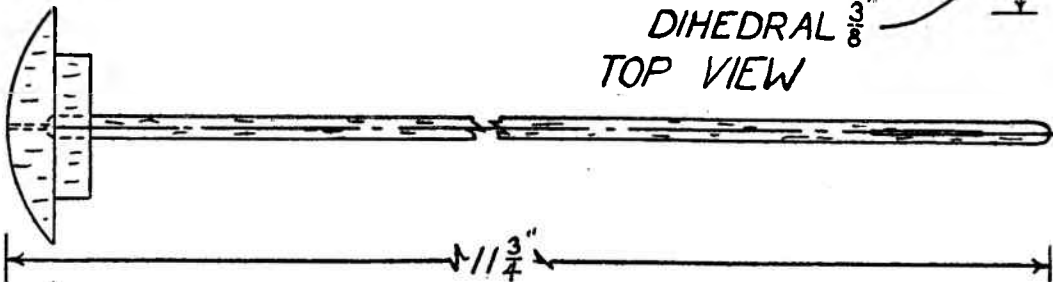

RING COWL  
CUT AWAY TO  
SHOW STUB  
WING ATTACHMENT

$1\frac{5}{8}$ " BALSA OR  
CELLULOID WHEELS  
MAY BE USED

PLAN NO 5

# Aerodynamics Simplified

This month, FLYING ACES begins a new series of interesting and very worthwhile lessons in simple aerodynamics, a subject which every aviation fan needs and wants to know. It's just such a course as you can usually get only at an aviation school, so get in on this first chapter in the series and don't miss your chance to be in on the ground floor.

\*\*\*

By Avrum Zier

**T**HOUGH the study of aerodynamics may appear to be an intricate study, it is quite the contrary, for it involves only the simplest form of physics and mechanics, and necessitates for a sound understanding the application of the lowest degree of mathematics.

Aerodynamics may be defined as that branch of dynamics which treats of the action of the air on bodies in motion through the atmosphere. The body in motion in our case is the airplane. Two separate terms comprise the term aerodynamics—"aero" meaning air or atmosphere, and "dynamics" the study of forces acting on bodies in motion.

The first two chapters of this series will treat of each term separately, and though no mention will be made of the airplane, its purpose is to give the reader the concrete foundation upon which aerodynamics is based.

The earth, due to its comparatively huge mass, exerts a gravitational pull on the surrounding atmosphere which prevents it from being thrown off into space by the centrifugal force set up by the rotation of the earth.

The atmosphere is composed of all the known gases, of which the following are its greatest constituents:

- Oxygen .....20.99%
- Nitrogen .....78.04%
- Carbon Dioxide..... .03%
- Argon ..... .94%

The complete combination of all the

known gases forms a chemical mixture which we commonly call air.

Air, being a gas, is subject to changes in pressure and temperature which effect its standard condition. The standard condition, or "Standard Atmosphere" upon which all calculations are based, is given by the N.A.C.A. for sea level conditions as follows:

- Temperature .....59° F.
- Pressure..29.92 inches of mercury
- Density ....002378 slug cubic ft.
- Specific Wt....07651 lbs. cubic ft.

Literally speaking, we are living at the bottom of a huge ocean of air that to the average layman seems void and calm. The ease in which he is able to move about makes it hard for him to realize that air, in reality, is composed of matter in an invisible state. It was estimated by Sir John Herschel that the weight of the air pressing down upon the earth is about 11½ trillions of pounds.

Though most of us are quite unaware of it, the average human body sustains a pressure of about 14 tons and, fortunately, is prevented from collapsing by an equal outward pressure.

It was discovered by Torricelli that a column of mercury about 30 inches high, if inverted into a bowl of mercury, will balance the atmospheric pressure acting on the vessel of mercury. The standard atmospheric pressure per square inch is 14.7 pounds, which means that a column of mercury one inch in cross-section and about 30 inches in height will sustain a pressure of 14.7 pounds, at sea level conditions.

As we ascend into the atmosphere, the height of the air above us becomes less, and so the pressure drops. Generally speaking, the drop in pressure is about one inch of mercury for every 900 feet of ascent. This, however, is only true for the first several thousand feet, after which the drop in pressure is less rapid. Figure 1 shows the pressure drop for altitudes up to 20,000 feet. At about 18,000 feet, the pressure is about 7½ pounds, or 15 inches of mercury.

Air is an elastic fluid which is easily compressed and expanded. In 1662, Robert Boyle, an Irishman, found that under a constant temperature, the volume of any perfect gas will vary inversely with the applied pressure. If the pressure acting on the gas was doubled, the volume would be decreased

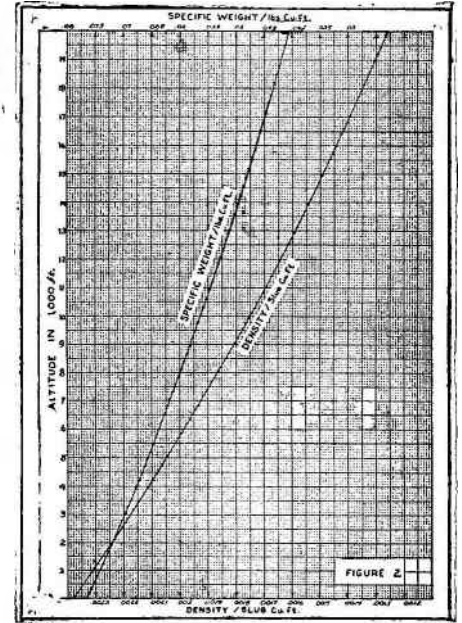

to one-half its original volume. This may be expressed as follows:

$$\frac{V_1}{V_2} = \frac{P_2}{P_1}$$

For example, if the volume ( $V_1$ ) of a certain gas, having a pressure ( $P_1$ ) of two pounds, is 10 cubic inches, what would be the volume ( $V_2$ ) if the pressure ( $P_2$ ) is increased to five pounds? Substituting in our formula, we have:

$$\frac{10}{x} = \frac{5}{2}$$

$$5x = 20$$

$$x = 4 \text{ cubic inches}$$

Air, just like any gas, is subject to expansion under an applied temperature. Standard air at sea level conditions is 59° Fahrenheit. As we ascend into the atmosphere, the temperature, just like the pressure, drops. The drop in temperature is about 1° F. for every 300 feet of ascent. This, however, is only true for the lower region of the atmosphere, which is on the average 7 miles high. At this point, where the stratosphere begins, the temperature is about -55° Centigrade, and remains such throughout the stratospheric region. This point is generally referred

(Continued on page 80)

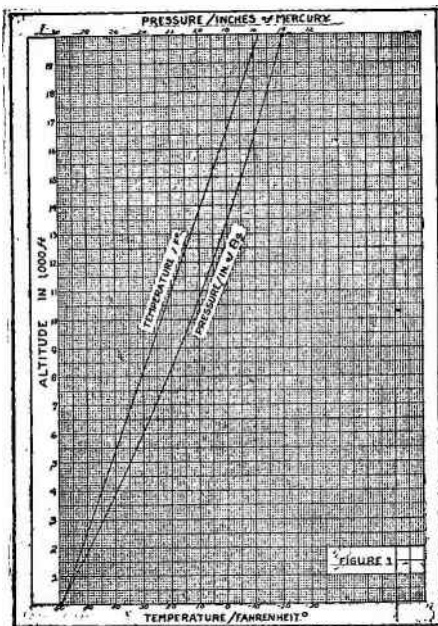

# Flying Aces Canard Glider

Many of you are gliding fans, we know, so here's something that should interest you. It's the Flying Aces Canard Glider, a model that has a slow, flat glide and will give you lots of fun and many excellent flights.

\*\*\*

**S**OME of you readers may remember the Contest Glider described in a previous issue of FLYING ACES. This new model, which we call the FLYING ACES Canard Glider, has many new features. These are as follows:

- 1—Tapered and more efficient wing.
- 2—Lower center of gravity, due to high wing mounts.
- 3—More holding surface for launching.

This model, like most Canards, has a very slow, flat glide.

## FUSELAGE AND WINGS

**T**HE fuselage is a piece of 3/16" x 5/16" balsa, shaped and sanded to the shape shown in the drawing on Sheet 2. The wing mounts should be cut from 1/16" sheet balsa, streamlined and cemented in place.

The smaller wing is cut to shape from 1/16" sheet balsa and sanded to an airfoil cross-section. When the two halves have been sanded smooth they should be

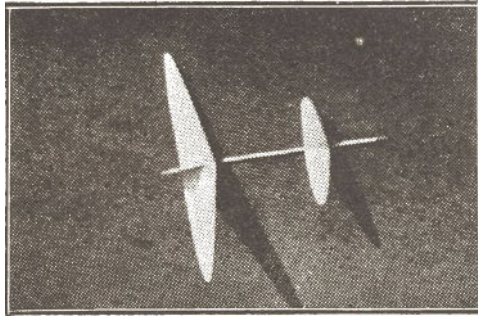

*Showing clearly the appearance of the finished Flying Aces Canard Glider, built according to the directions given here. It's a clean-looking model, and we wish you luck with it.*

By Julius Unrath

\*\*\*

cemented together to form a dihedral of 2". The large or rear wing is constructed in the same manner as the smaller one, except that the dihedral angle is 2 3/4". In assembling the model, extreme care should be used to see that the front and rear wing are perfectly aligned with the fuselage. When the cement has dried, the rudder may be shaped and streamlined, then cemented in place.

## FLYING THE MODEL

**A**FTER giving the model two coats of dope and a sanding, it should be balanced by gliding. If the model stalls, add some modeling clay to the nose; if it dives, take away some modeling clay, or cut off some of the nose. Excellent flights can be obtained with this model if care is used in the construction.

To launch the Canard, grasp it with the thumb and middle finger under the rear wing, using the index finger at the rear of the fuselage under the rudder as a "thrust."

Please enclose stamp when asking for information, and address letter to me, personally, in care of FLYING ACES Magazine. Write in and let us know how your models turn out.

## From the Model Builder's Workbench

### GUNS ON YOUR PLANE

**A** GOOD machine gun can be made of a soda straw, a piece of sheet balsa, and a gun snout of one sixteenth square balsa. Cut the soda straw to any length wanted. Then look up a good diagram or drawing of a machine gun. If you have kept your old FLYING ACES, you can find excellent gun drawings in the article, "Machine Guns of the World War," published in the March, 1934 issue. With carbon paper, trace the last half of the gun you want. The easiest guns to make are the Parabellum, Spandau, Vickers and Maxim guns. Cut from sheet balsa and paint.

Here is a good way to dope a plane with water. Use a sprayer, rather than your fingers, to dab on the water. You can get good sprayers in any Five and Ten. When spraying the model, stand at least eight inches away, fifteen inches at the most. This results in an even film of water. At first, you'll make mistakes, and probably spray unevenly, but don't give up. With a little practice, you can determine just how much water your model needs.

GEORGE MULLER.

### IMITATION CYLINDERS

**I**MITATION cylinders for radial engines can easily be made in the following manner. First take an ordinary cigarette and give it a coat of good, fast-drying glue (not cement), and wind a length of fish line around the cigarette. When the glue is thoroughly dry, give the fish line two coats of black lacquer or dope. When the lacquer or

dope has dried, cut off cylinders of whatever size you need and poke out the part of the cigarette left inside. This will give you an imitation cylinder that is very light and looks very realistic.

Rocker arms can be made for the cylinders with short lengths of strip balsa. Valve stems can be made by snipping off the heads of stick pins and cutting them the length of the cylinder. Two rocker arms and two valve stems are cemented to each cylinder, and the completed job is cemented to the crank case.

A. ANNEN.

### ODDS AND ENDS

**V**ERY often, the usual process of bending bamboo over a candle flame results in burned wood. It can be safely and easily bent over the point of a hot electric iron. Balsa may be bent easily by softening it with heat applied by means of corks which have been soaked in boiling water.

Before starting to paint, wet your brush with dope thinner. This will absorb the paint already in the brush, and enable you to get the brush clean by rubbing it with a cloth.

DEAN MENDENHALL.

## Attention, Model Builders!

**FLYING ACES wants plans and directions for building flying scale models of the latest modern planes. In order to be printed in this magazine, drawings must be done in India ink, and must fit a 7 x 10-inch page. Plans should not exceed six pages. Photographs of completed models must accompany plans. Send in your work, model builders, and get it printed!**

•

Sheet - 1

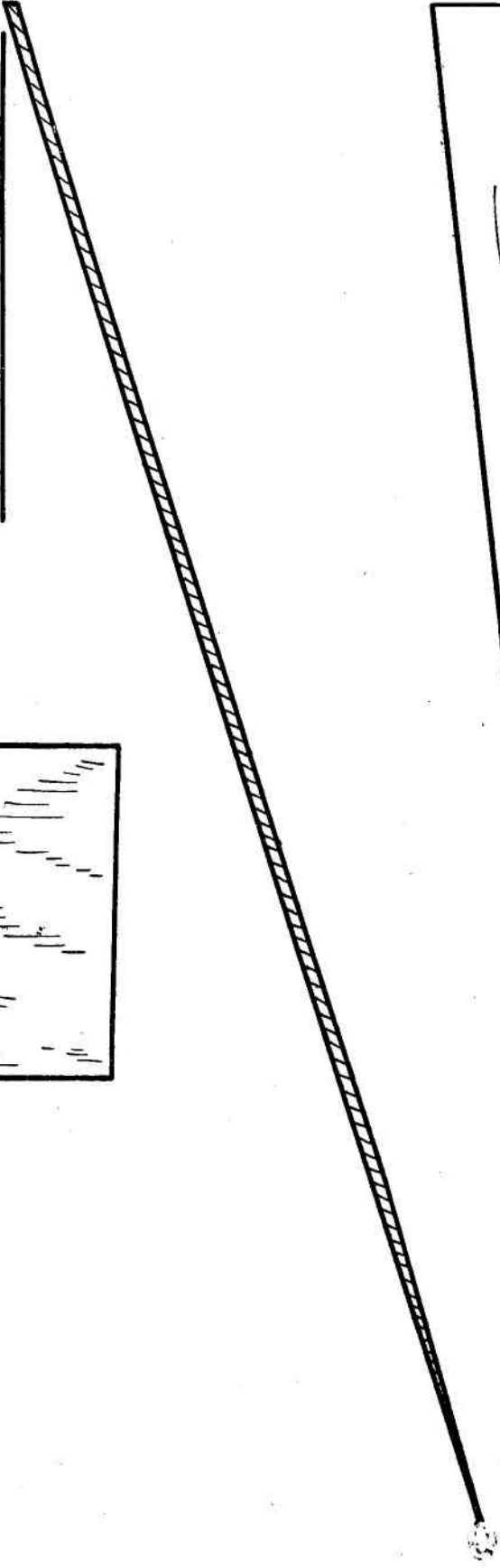

JULIUS UNRATH R.

A A

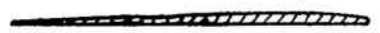
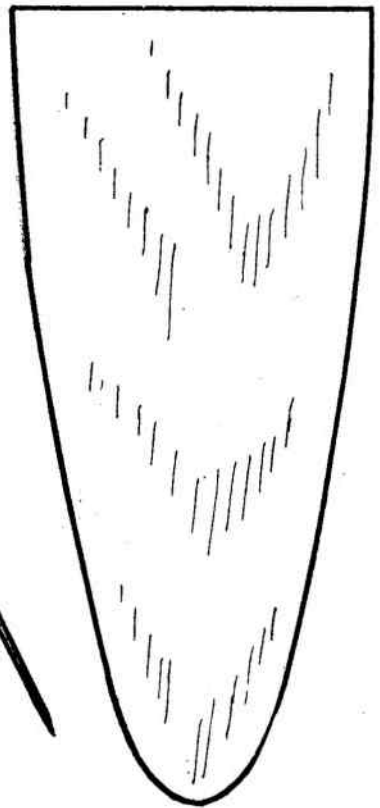

① Use a medium grade  
of balsa.  
② Use cement for  
fillets.

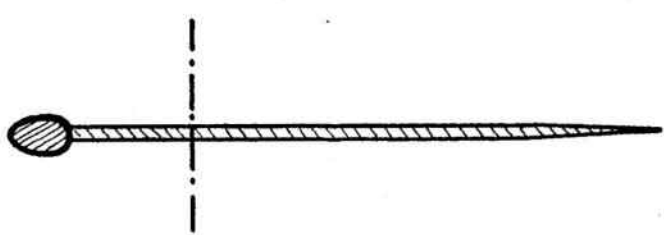
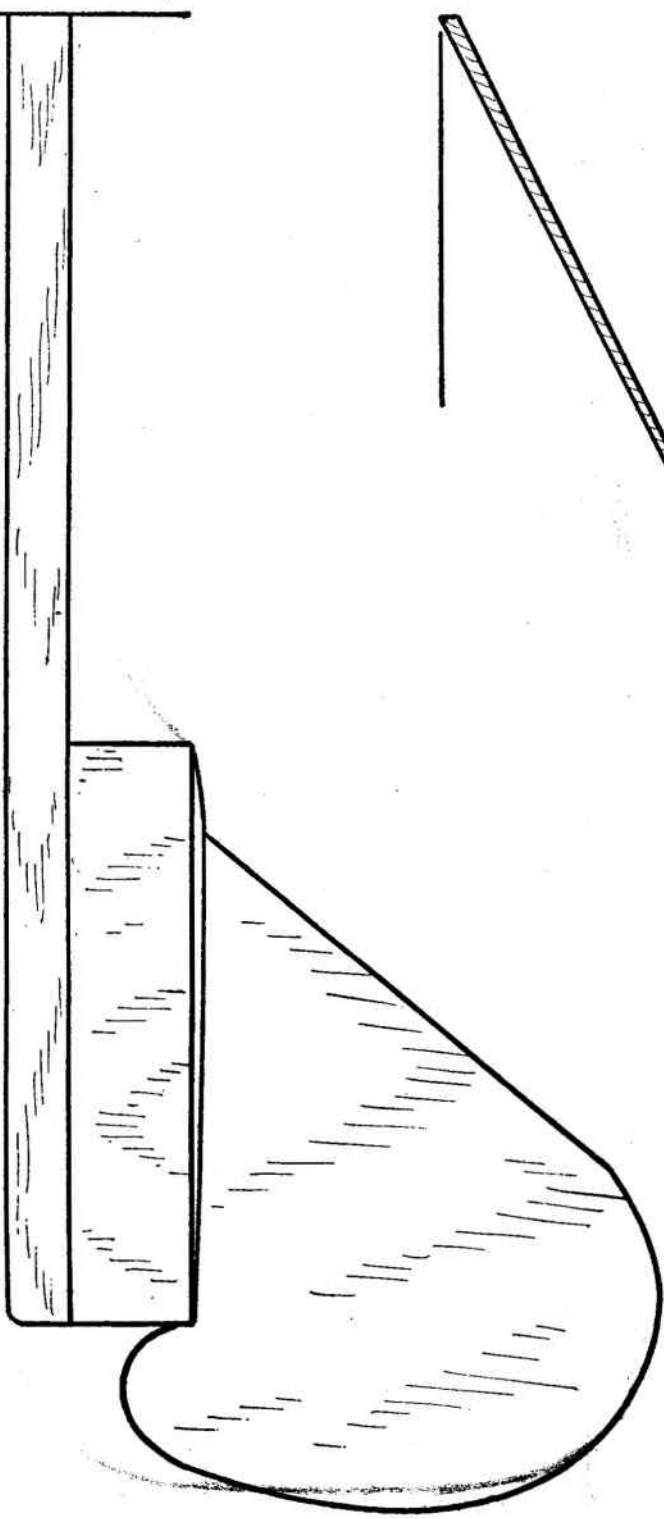

A A

Sheet - 2

JULIUS UNRATH B.



# Build the Dewoitine D-500

\*\*\*

## Editor's Note:

*Editor's Note:* Through an error, the three-view layout of the Dewoitine D-500 was omitted from the plans printed in the July FLYING ACES. We are printing this layout, which includes the wings, on this page, so that the many of you who are building the Dewoitine will be able to complete your models. Good luck to you!

\*\*\*

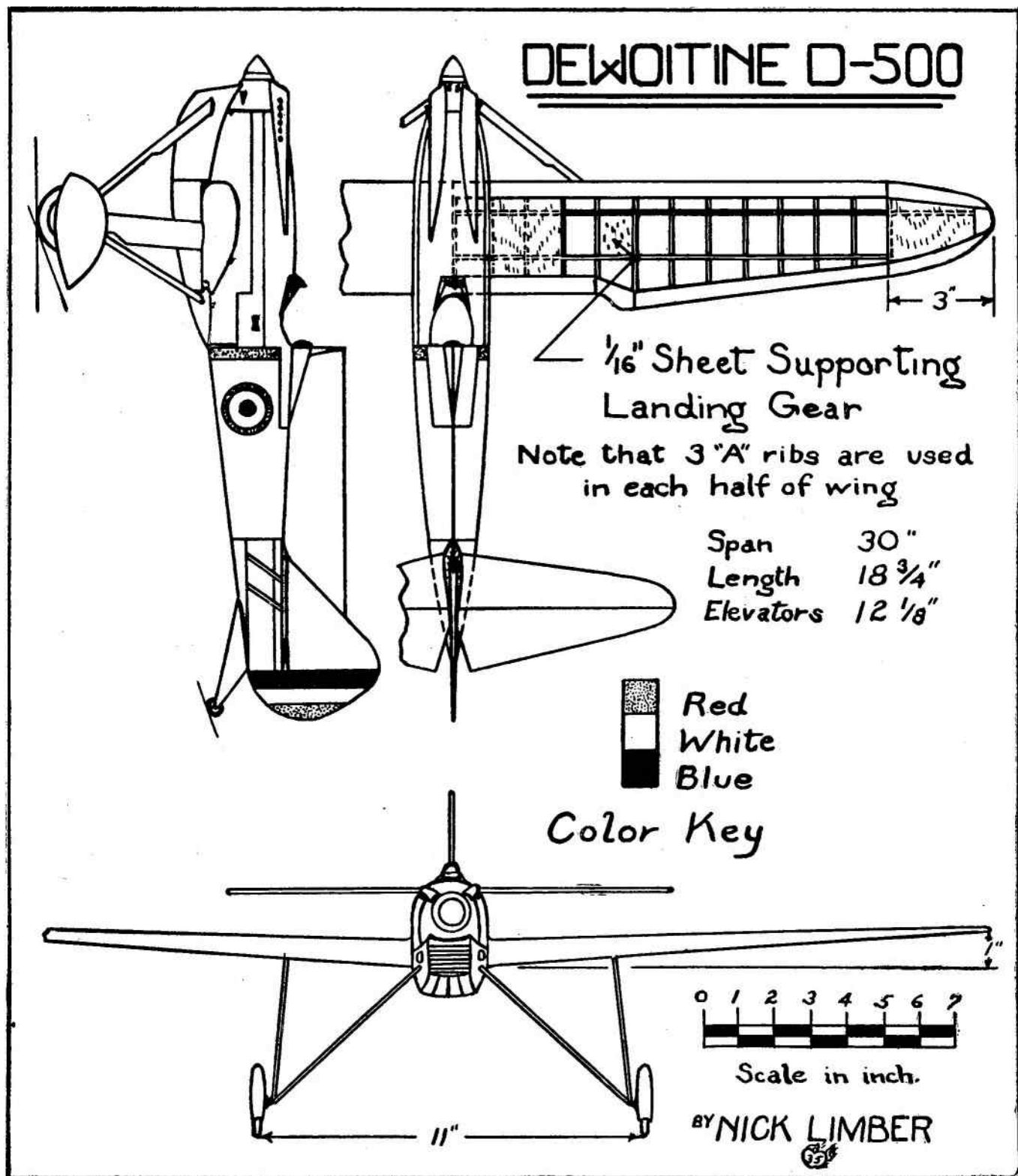

**FLYING ACES  
STRATOSPHERE  
PURSUIT**

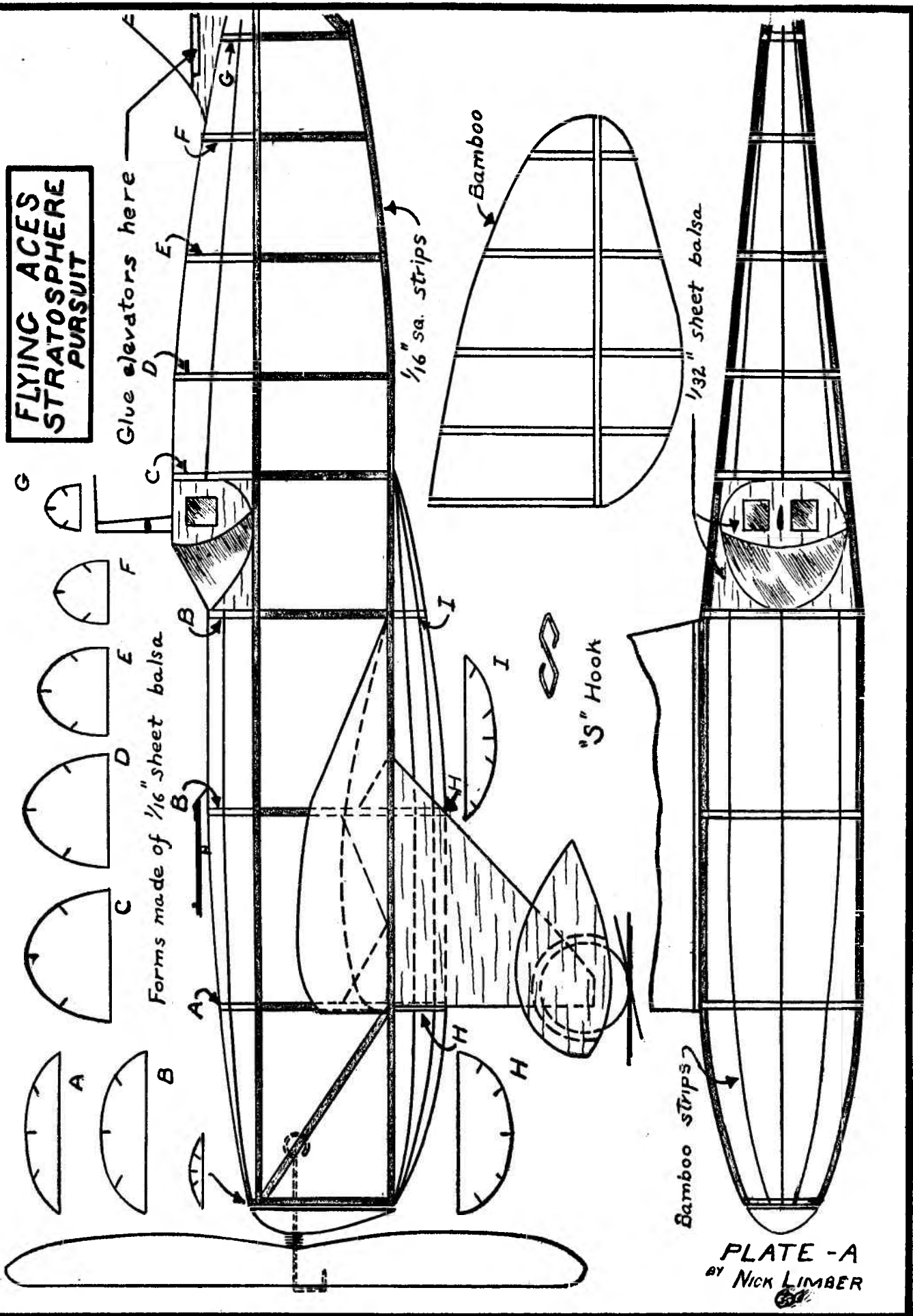
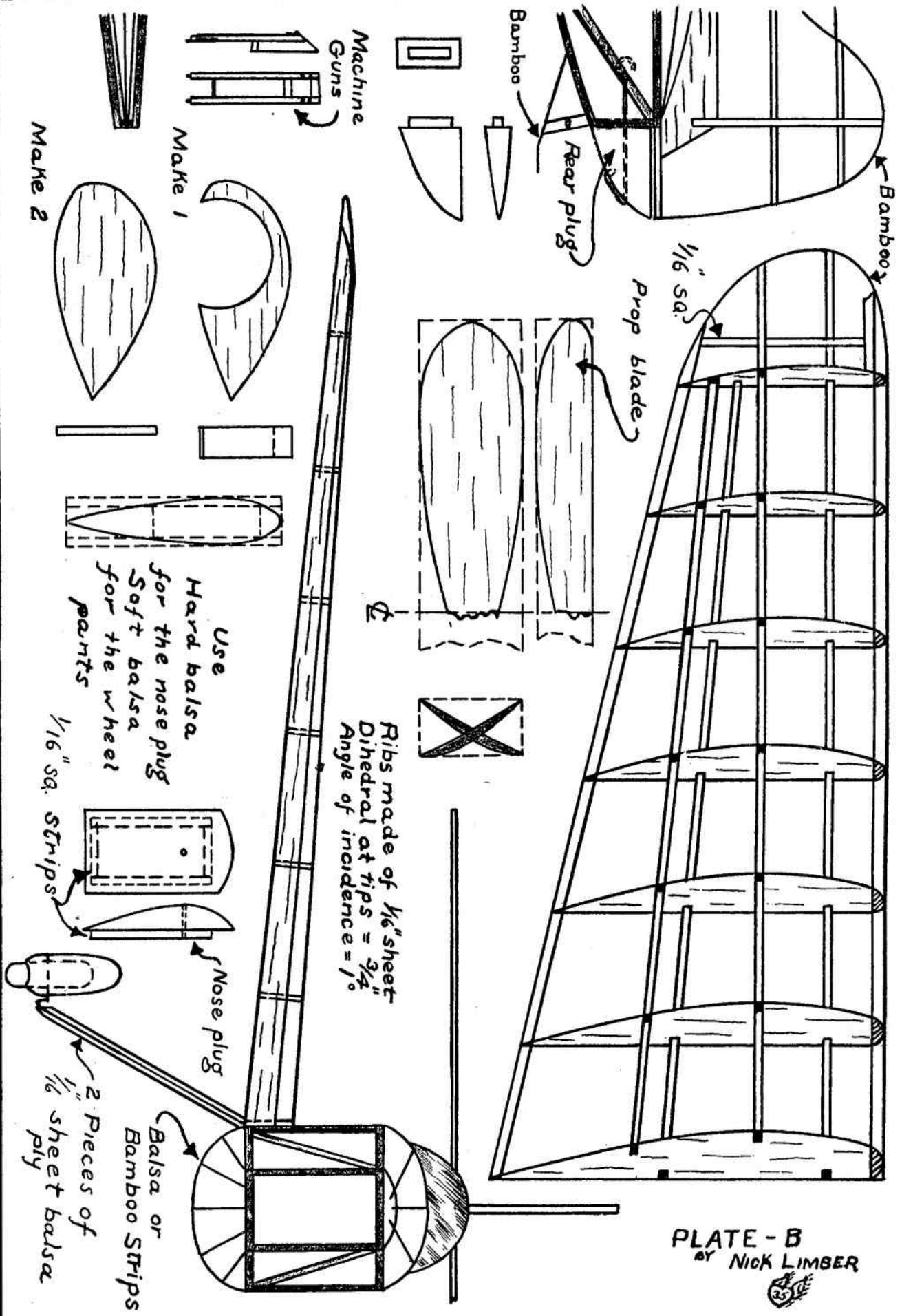

PLATE - A  
BY NICK LIMBER

FLYING ACES STRATOSPHERE PURSUIT



# JOIN THE FLYING ACES CLUB

TO advance the cause of aviation, over 40,000 men and women, boys and girls, have banded together to form the Flying Aces Club. To become a member, fill in and mail the application coupon below, along with a stamped, self-addressed envelope for return of your official membership card.

It costs nothing. There are no dues. After becoming a member, you will be all set to win your Cadet Wings, Pilot Wings, Ace's Star, and perhaps the D.S.M. Take the first step NOW—fill in and mail the membership coupon!

It's easy to start an F.A.C. Flight or Squadron. Tell your friends about the F.A.C. and its official magazine—FLYING ACES. Ask them to buy a copy and join the club. Counting yourself, six members are necessary to form a Flight; a minimum of 18 for a Squadron. To become a member, each applicant must fill out and mail the application below. Be sure, when writing, to enclose a stamped, self-addressed envelope for your reply. This is important.

## Honorary Members

<b>President and Mrs. Franklin D. Roosevelt</b>	
Casey Jones	Rear-Admiral Byrd
Wiley Post	Capt. Edward Rickenbacker
Al Williams	Colonel W. A. Bishop
Col. Scarani	Major G. A. Vaughn, Jr.
Gifford Pinchot	Mrs. Gifford Pinchot
Major von Schleich	Willy Coppens
Lieut.-Col. Pinsard	General Balbo
C. E. Kingsford-Smith	Josef Veltjens
G. M. Bellanca	Amelia Earhart Putnam
Capt. Boris Sergievsky	Senator David I. Walsh
Colonel Roscoe Turner	Lowell Thomas
Charles W. A. Scott	Tom Campbell Black
Richard C. DuPont	Eric Kingsford-Smith
Amos 'n' Andy	Walt Disney
Jackie Cooper	Frankie Thomas
Lieut.-Col. Theodore Roosevelt	Wallace Berry

## AWARDS AND HONORS

### The D.S.M.

The Flying Aces Club Distinguished Service Medal is the highest award of the Club and is given to those whose work on behalf of the F.A.C. is "beyond and above the call of duty." It has been awarded for obtaining prominent men and women as Honorary Members, for exceptionally successful activity in the promotion of the Club, for outstanding work in covering the secret assignments of G-2.

Winners of the D.S.M. who merit further awards will be given beautiful bronze props. Worn on the ribbon of the D.S.M., they may be compared to the bronze palms awarded to winners of the Croix de Guerre. The highest award of the F.A.C. is the D.S.M. with three props.

### The Ace's Star

The Ace's Star is awarded to regular members of the F.A.C. who have qualified for their Cadet and Pilot Wings and who have succeeded in enrolling five new members in the Flying Aces Club. Each new member must fill out the Application Coupon below. Get five of your friends to do this, send in their applications all together and win the F.A.C. Ace's Star.

### Official Charters

F.A.C. Flights and Squadrons are recognized only when they have been awarded Official Charters. These Charters are illustrated to depict the various steps of advancement in aviation, and the wording is in keeping with the high ideals and purposes of the Club. They are printed on a very fine grade of paper and the names of the Squadrons are hand-lettered. Charter applications must always be accompanied by a complete list of members with their addresses. For the Flight Charter send 25c, for the Squadron Charter 50c, to cover costs.

### Volunteers for G-2

G-2, the Inner Circle of the F.A.C., is open to a restricted number of members who are qualified for Secret Service activities. Those who are chosen will have unusual opportunities to win the Club's Distinguished Service Medal. Those who are accepted will be given a secret number and identification card as well as the secret code. Assignments will be made by letter and code.

**FLYING ACES CLUB—67 W. 44th St., New York City**

## Attention, F.A.C.'s!



WE not only have a new supply of the handsome F.A.C. Club Ring, but now offer you the beautiful Identification Bracelet, as well. Both are finished in antique silver—the ring being self-adjustable to insure a perfect fit. Either ring or bracelet will be sent postpaid anywhere in the U.S.A. for only 50c each.

COUPON  
No. 33



### Save This Coupon for the NEW CADET WINGS of the Flying Aces Club

All members with Official Membership Cards are eligible for Cadet Wings. This coupon, with two others and 10c, entitles members to Cadet Wings. Do not send this coupon alone. Save it until you have three. Then send them in all together with a self-addressed envelope and 10c to cover cost of wrapping and mailing. Only one pair of Wings to a member. If you lose yours, send 25c for new ones.

Canadians send International Reply Coupon for 15c. British send one shilling in coin or International Reply Coupon for one shilling.



COUPON  
No. 30

### Save This Coupon for the NEW PILOT'S WINGS of the Flying Aces Club

All enrolled members who have won their Cadet Wings are eligible for Pilot's Wings. This coupon, with four others and 10c, entitles Cadets to Pilot's Wings. Do not send this coupon alone. Save it until you have five. Then send them all together with a self-addressed envelope and 10c to cover cost of wrapping and mailing. Only one pair of Wings to a member. If you lose yours, send 25c for new ones.

Canadians send International Reply Coupon for 15c. British send one shilling in coin or International Reply Coupon for one shilling.

### August Membership Coupon

I, the undersigned, hereby make application for membership in the Flying Aces Club. I agree to live up to its rules and regulations; to foster the growth and development of aviation; and cooperate with all other members in the work of spreading aviation information, building up confidence in flying for national defence and transportation. I will aim to build up the Club and its membership, and do my best to win the honors that the Flying Aces Club offers.

My name is .....

Age .....

Street .....

City ..... State .....

Mail this application, enclosing a self-addressed, stamped envelope. Canadians send International Reply Coupon worth 5c. British send a similar coupon worth sixpence.

# Citation and Awards

## of the Flying Aces Club

The Distinguished Service Medal of the Flying Aces Club has been awarded to the following members of G-2 for exceptional services to the club:

Charles Green	Leonard Tarver
John Murphy	Walter Woelker
Ellsworth Nelson	Robert Lowe
Bob Roberts	Thomas Janda
James O'Malley	James Foster
Leslie Woods	Lewis Nelson

The following winners of the Distinguished Service Medal of the Flying Aces Club have been given the first award of the bronze props for additional services to the club:

Dinny Waterman	Carl Ulanowicz
Jack Staff	Henry Hermanovich
R. D. Hatcher	R. G. Cooper
Wayne Grant	Edward Wozniak
Casimir Kedzior	LeRoy Wilderman
Ronald Smith	Earl Baggs
Edward Stark	Joseph Von Waldron
Ted Jacobs	Edward Nasin
Alfred Costen	Leeland Reeser
Jack Sullivan	Walter Allen
Joseph Keefe	Blakley Hargis
Norman Wrightson	Warren Huffman
Edmund Scarchilli	Donald Leiter
Raymond Dowsett	Dave Horowitz
Leslie Papier	S. Schulman

The following winners of the first award of the bronze props have been given the second award of the bronze props for additional services to the club:

Edward Sandgren	David Score
John Banich	John Bores
Gaston Auger	Bob Rousseau
Fred L. Voorhees	George Forman
Christian D. Berger	Robert Thompson
Leonard Czaplicki	Frank Burgenheim
Charles Ceeting	

The following winners of the second award of the bronze props have been given the third award of the bronze props for additional services to the club:

John Trotta	Charles Pelant
George Marvin	David Jamison
Albert Rumpf	Raymond Wagner
Adolph Betterini	Russell Moore
Douglas Fadden	Arthur Freeman
Eugene Mulcahy	William Tymeson

The following members of G-2 of the Flying Aces Club have been awarded the silver F.A.C. ring for exceptional service to the Club:

Alexander Taylor	William Clay
Charles Boyd	George Bertolozzi
Donald Hopkins	Walter Smith
W. L. Stewart	Leo La Riviere
Anthony Konevage	Paul R. Guerrero
Albert Kirschner	Charles Hoelle
Helen Greene	Martin Schatzer

The following members of G-2 have been cited by the Flying Aces Club for exceptional services to the club and are being considered for the Distinguished Service Medal:

Lester Schwadron	Dante De Angelis
Frank Dyer	Mary Thompson
Walter Reinsmith	Wallace Cook
Joel Bell	Earl Case
Francis Holmes	Oliver Nelson
James Flaherty	

# Flying Aces Club News

## All Questions Answered

We're off to a flying start, this month, F.A.C.'s! Look over this program—new honorary members, new squadrons, and a flight of new ideas for keeping things humming on club tarmacs from California to England and back again. All set? Let's go!

✱ ✱ ✱

**G**ET ready for a fast take-off, F.A.C.'s! We've got a lot of airways to cover this month, so check your engines, pull on your goggles and we're off!

Let's start with three cheers and a tiger for our new honorary members. We're glad to welcome Jimmie Allen, that well-known ace of radio who broadcasts those hair-raising "Air Adventures of Jimmie Allen" and heads the "Jimmie Allen Flying Club." When asked if he'd like to become an F.A.C., Jimmie wrote: "Would I like it? It would make me mighty proud. Just notify me when I'm elected."

You're notified right here and now, Jimmie, and it makes us mighty proud to do it. Gene Shaffer, of Oakland, Cal., and John Hoover, of Philadelphia, Pa., got us this new star for our honor roll. Keep up the good work. Captain W. R. May is another honorary F.A.C. who has just landed on our tarmac at the invitation of Bruce Russell, of Edmonton, Alberta, Canada. Captain May is now at the Fort McMurray station of the Canadian Airways, Limited. F.A.C.'s of the fair sex will be especially happy to welcome Betsey Barton, of the *Airwoman* magazine, to the honor list. John Brennan introduced this new member.

And still they come! Edward A. Kalb, of Long Island, New York, has recruited Major J. Nelson Kelly, manager of the Floyd Bennett Airport, who is also connected with the Lear Radio Development Corporation, of New York City. Thanks, Edward. That's what we'd call making a perfect landing. We hope Major Kelly will have as good a time on the F.A.C. tarmac as he does at Floyd Bennett Field.

Speaking of tarmacs, here's an invitation from Mr. G. D. "Jerry" Meek, manager of the Derby Flying School, San Francisco Bay Airrome, Alameda, Cal., to drop in on his runway. This cordial member of our honorary group writes: "We hope to see your gang often at the airport, and hope that you will make our club room your headquarters when here." That rates a salute from all of us, and while you're at it, let's give one to Dallas Burke, of Alameda, Cal., who brought Mr. Meek into the F.A.C.

And here's a good note (!) for all musical F.A.C.'s. We're dusting off the trumpets in honor of Kay Kayser, well-known orchestra leader, of Philadelphia, Pa., who has joined our club at the invitation of Robert Neeley, of Chicago, Ill. And that reminds us—how about a good club song for the F.A.C.? We'd like some ideas on that.

Squadrons are humming these days. Let's look in on a couple of them. Major J. P. Tumulty and his Cleveland, Ohio, group report a hot and heavy competition in the squadron's model building contest. He also states that the treasury report is pretty good, and hopes it will continue to be. So do we, major! And here are some good ideas for raising your rating in your squadron, the way Craig Smith, of Chicago, Ill., is doing in his. He suggests getting up tests for ranking honors from second lieutenant to colonel. One test, for example, is a pretty stiff questionnaire on types of aircraft, flying technique, etc. It's a good way to keep up on your flying dope, as well as to get ahead in your squadron. That's using your head, Craig!

While we're on the subject of hard thinking, let's not forget that the Flying Aces Club has a strong cause to advance—the promotion and advancement of aviation. We've all got to do our bit in this work, and Allen Reasoner, of Petersham, Mass., has figured out a clever and practical way to do his. He's conducting a fine campaign to get everyone he knows to take a plane ride at their neighborhood flying field. Friends and relatives, old and young, are answering his call. He's making lots of people realize that it's better to travel on air. And Allen believes in starting at home. He's gotten his own six-year-old brother to go up twice. Happy landings, Allen! You certainly deserve them.

We wonder how many of our F.A.C.'s are autograph hounds. Ralph Short, of Kingston, N. Y., tells us he's proud to be one, and he ought to be. He has over fifty autographs of famous flyers, including such well-known pilots as Clyde Pangborn, Jimmie Doolittle, Amelia Earhart, Captain Frank Hawks, etc. Four of these pilots took Ralph up for a free flight when he asked for their autographs. That's enough to make autograph fans out of all of us. How about it, F.A.C.'s?

Let's step across the sea a minute, and three-point down on the tarmac of a loyal English F.A.C. Al C. Such, of Handsworth, England, writes us: "I have resigned from the Navy to keep in the Flying Aces Club, and have had official permission in writing from the British Air Ministry to wear the official uniform of the F.A.C. This means that they recognize our club, as it is illegal to wear military or naval uniforms here unless authorized." Glad you feel that way about the club, Al, and we hope you'll have many happy take-offs in your F.A.C. uniform.

Taxi in on this special request from "Ace" Miller, 2730 E. 79th St., Chicago, Illinois. He would like other Chicago Flight and Squadron leaders to get in touch with him as soon as possible. He has something of interest to tell them. Sounds mysterious, but the secret will probably come out on our F.A.C. bulletin board in time. We'll be watching for it, Ace! And now, in case any of you lone-wolf F.A.C.'s are wandering around without a home tarmac, here's a chance to find yourself a squadron. Bernard Posner, 420 Hudson Avenue, West New York, N. J., would like to hear from all F.A.C.'s interested in a newly forming club contact. He says applicants will be tested. There's a challenge, all you Jersey F.A.C.'s! Let us know how you come out.

Way up north in Canada, Leonard Robinson, of 777 Lansdowne Avenue, Toronto, Ont., is sending out an S.O.S. for Toronto members. Back in the States, again, we find Col. Charles E. Riley, 5926 Loretto Avenue, Philadelphia, Pa., offering a helping hand to all Philadelphian F.A.C.'s. Just send him your address, and he will assign you to the flight nearest to you. That's service, Colonel Riley! We know you'll get a big response.

No, we haven't forgotten our Limey friends. Peter K. Walley, 249 Whitehouse Lane, South Norwood, Croydon, England, wants F. A. C. members residing near him to get in touch with him. And just taxiing across the line as we go to press comes a call from sunny California, where Stewart Booth, of 3719 Villa Terrace, San Diego, is organizing a West Coast squadron.

That winds up this month's patrol. But the F.A.C. airmail pilots are still going strong, and we've had to leave a lot of interesting news for next month's flight. Until then—keep your club props revving!

This section of FLYING ACES is at your service, F.A.C.'s. Send in your questions and requests for air information, and we will be glad to answer them here in the order received.

R. W. Jaggard, London, England:—Thanks for the newspaper clipping on the argument concerning the war's greatest airman. So Mannoek was an Englishman, born in Canterbury, eh? And they had been telling us he was an Irishman.

Joseph Muller, New York:—The list of British ships used for bombing would comprise the greater part of the British list, for practically all types were used in bombing, on one front or another. The list of regular bombers, of course, includes the Hanley Page, D.H.4, D.H.9, D.H.9a, Fee, and the Short seaplanes. America had no bombers of her own, but used British and French ships, particularly Salmsons, and D.H.4's.

Charles Sussman, Jersey City:—Aspect ratio is the ratio of the chord of the wing to its length.

Jack Kaczanowitz, Jr., Northampton, Mass.:—If you had a limited commercial license, you would still have to pass the entrance exams to get into the Army Air Service, but of course any training would be a big help.

Bert Dalmer, Chicago:—The ship you referred to with the lower wing under the body, is no doubt the Berliner-Joyce. What the other ship is, I can't tell from your description, as I didn't see the movie you mentioned.

Bill Williams, Farmville, N. C.:—A few enlisted men are selected every year for flight training in the Navy, but they are unusual figures, and far above the average enlistment.

Dwain Kuhn, Miles Center:—There is no radical difference between the Albatros D-3, and the D-5, except for the increased power plant.

Jack Logan, Orange, N. J.:—I do not know whether you have to make a voluntary jump with a parachute if you join the Air Service, or not. One used to, I believe. Personally, I think everyone should make at least one jump, to gain confidence in the device.

Lester Hellenberg, New York City:—I served with No. 22 Squadron, R.F.C. I know of no American ace with 40 victories. Linke Crawford was an Austrian.

**Andy Jacko, Detroit:**—The model plane supply houses that advertise in this magazine, usually have most war-time ship plans. I am not certain about the Kondor, however, as it is a little-known job. It is quite possible that there are no model plans of it available. The fin, elevators and rudder together are usually called the tail assembly. Your question about wearing glasses and getting a government job is not quite clear. What sort of a job are you referring to?

**Ernest A. Pring, Chiswick, London, England:**—Thanks for the pictures you sent us, but we have had them all, and have run several features on the men you mention. If you have original photographs, we would like to see them, but we get all the magazines you clipped these pictures from. We are glad you like our magazines, and will have to put your name down on our list of Airmail Pals.

**C. J. Rogers, Dallas, Texas:**—The full detail of the ships you desire will appear in SKY BIRDS in the next few weeks. I can't guess at figures like that.

**H. L. Bowker, Absecon, N. J.:**—Thanks for your long letter. It was very interesting. You must go through high school to pass the entrance examinations for the colleges that offer good aeronautical courses. I refer to New York University and Massachusetts Institute of Technology.

**Berkley Davis, Church Road, Va.:**—Where have you been all summer? The fastest plane in the world is the Italian Macchi-Castoldi racing seaplane. It has done 423 miles per hour.

**Lees Brown, Rome, N. Y.:**—See the description of machine guns in the March issue of FLYING ACES. That will give you all the details of the Lewis gun you desire. You're a red hot artist, eh?

**William Van Horn, Towson, Md.:**—There is no such thing as an official Army plane. The Army uses many types for various duties. They include Douglasses, Boeings, Curtisses, Martins, Keystones and many others. We have shown many of these types in our pages. See SKY BIRDS, too.

**Lawrence Osborne, Santa Barbara:**—Your machine-gun question has been answered a dozen times. The Vickers was the best fixed gun and the Lewis most suitable for a movable weapon. Thaw did not have a special insignia of his own that I know of. They still make Spads and Nieuports, yes. I still like the Army Air Service, but the Navy is probably better equipped.

**George Brown, Meriden:**—The speed of the Morane-Saulnier shown in the drawing of our January edition was originally drawn as 232.8 and somehow in the reproduction the period was lost, but it should be pretty evident to everyone that no ship could do 2,328 m. p. h.

**Herbert Lindblad, Oyster Bay:**—The New York University course would be preferable to the other you mention. I do not have figures on the tuition charges, but would advise you to get in touch with the school and get all the information there, for there are several angles to it, depending on just what courses you take. We are considering an article on this important subject.

By ARCH WHITEHOUSE

## Airmail Pals

In order not to keep you waiting so long for Airmail Pals, we are printing here a list of those who want to hear from other F.A.C.'s. We are sorry that we do not have space to print the entire letters, but the right-hand column will give you an idea of the writers' interests.

Name	Address	Description
ALONZO C. BREWER	Sta. Hospital, Ft. Benjamin, Harrison, Tenn.	Handy with his fists. Has fought in the ring.
GLADYS POE	R.F.D. No. 2, Hemming, Tenn.	20. Another Southern belle.
FRED VOORHEES	Box 125, Miller Place, N. Y.	15. Collects airplane and railroad snaps.
JACK DOWDY	P.O. Box 3, Eastoner, S. C.	Knows planes from A to Z
ROBERT ROCHFORD	60 Centennial Ave., Lane Cove, Sydney, New S. Wales, Austral.	Aussie beginner with lots of hobbies.
EUGENE LEVITT	1381 Coney Is. Avenue, Brooklyn, New York.	13. Has plane plans to trade.
C. E. McDONALD	2362 Flora St., Cincinnati, O.	14. Another plan trader.
BILL LAPER	154 N. 20th St., Warwood, Wheeling, W. Va.	12. Wants to form squadron. Neighborhood boys, write.
CHAS. TRUAX, JR.	563 South Sandusky Ave., Bucyrus, Ohio.	Model builder—as who isn't?
RICHARD STEINKO	2208 Hillgen Ave., Detroit, Michigan.	Wants to know how to get pen pals. Tell him.
LUCILLE GRIMM	41 Wall St., Newark, N. J.	The lady likes long letters. No postcards, please.
MATTHEW KLUTER	241-02 Memphis Ave., Rosedale, L. I.	Has built 20 models.
R. L. SCOTT	Owings, Md.	Wants girls to write. See above.
GEO. SCHLUETER, JR.	Canistota, S. Dakota.	Interested in aeronautical engi- neering.
TED LONDREGAN	464 W. 28th St., Erie, Pa.	Swims like a fish, he says.
BILLY GILLET	7642 Beckett St., Tujunga, Calif.	15. Wants correspondents from England and Canada.
MELVIN LIVERS	175 E. 79th St., N. Y. C.	S.O.S. for F.A.C.'s.
LOUIS TERRONE	76-06 Woodside Ave., Elmhurst, L. I.	Veteran model builder.
EDWARD DESJOURD	West River St., Uxbridge, Mass.	Our stories his hobby.
SHIRLEY WILLIAMS	Leaburg, Oregon.	Easy to get along with.
BILLE SCHWEM	60 East Stewart Ave., Lansdowne, Pa.	Likes all kinds of pen pals, from anywhere.

### Happy Landings

(Continued from page 22)

Mr. Howard expects to do his racing at high altitude.

The most interesting feature of the ship is that it carries three special fuel tanks, all bearing different octane values. The 100 gallons in the fuselage are of 80 octane value. The 50-gallon tank in the center-section carries 87 octane value fuel, and the wing tanks hold 100 octane value fuel. The idea is that the higher octane fuel is used for take-off, climbing and in emergencies, while the cheaper grades are used for straight cruising.

We hope this settles all this mystery about a ship that really has no mystery to it at all.

### Scourge of the Spectre

(Continued from page 6)

A terrific wave of heat drove his dazed mind from its stupor. Where the burning plane had dropped out of the ball of fire was a hole through which air was being sucked upward. Flattened out like a colossal doughnut, the green mass was now swiftly dropping to earth. Strange was five hundred feet away, but he seemed almost on fire. Crouching low, he hurled the Spad away.

WHEN he sat up, almost a mile away from the drome, he could still feel that fearful heat. He gulped in breaths of parched air, zoomed up to a cooler level. Shading his eyes, he gazed toward the stricken base. That great ring of greenish fire had settled upon the ground, spreading its dreadful ruin to the main group of hangars and barracks.

He climbed to four thousand feet, spiraling to keep near the scene of the holocaust. Suddenly, from the clouds just above his ship, came the fierce rattle of machine guns.

Tracers were streaking the sky from two directions. A Nieuport slashed between Strange and the moon, Vickers spitting red. In a moment he saw another Nieuport charging from the other side, guns blasting toward a blurred shape which dipped toward the clouds. Abruptly, the flitting shape lifted.

Strange's hand turned cold on the stick. In the half-light, a blackened skull showed from the pit of that zooming ship. His incredulous eyes raced over the charred wings of the plane. It was impossible that the green fire had not burned that ship in a twinkling.

He jumped. Tracers from both Nieuports were ripping into the back of that skeleton figure. But the skeleton did not fall!

The message on Lorton's map flashed back into his mind. "Can't be killed . . ." What unholy power did that green fire have to change men to deathless skeletons?

The fire-scorched ship had swiftly zoomed, both Nieuports following.

## MISSING WORDS CONTEST No. 16

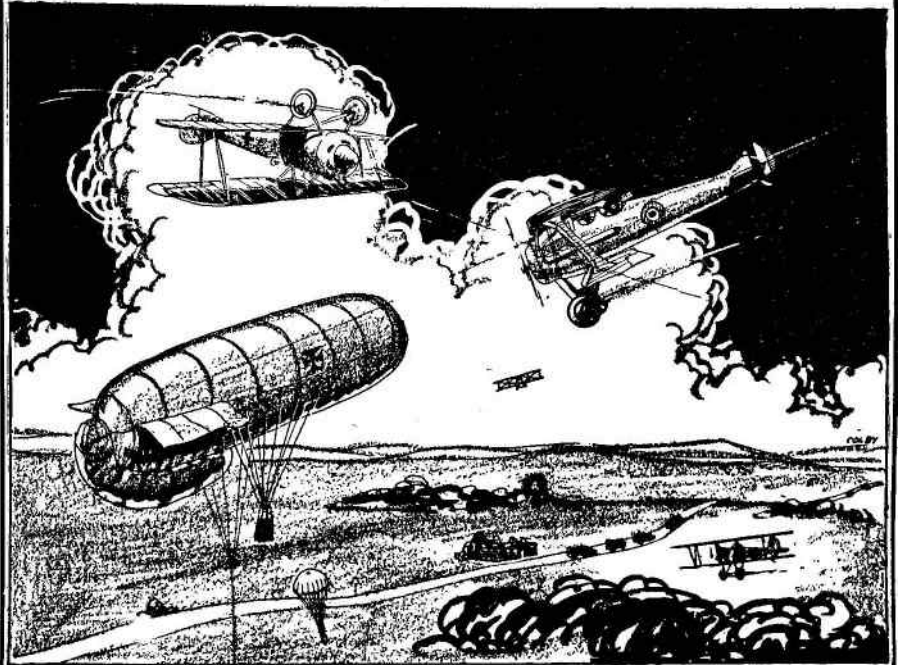

### Win a Flying Scale Model of the Dewoitine D-500

in Missing Words Contest No. 16

FIVE PRIZES

- First—Flying scale model of the Dewoitine D-500, popular French ship.
- Second—Regulation flying helmet and goggles.
- And Three Prizes—Kit for Fokker Triplane model—guaranteed to fly.

#### To Win This Contest:

In the above picture the artist has told a story—and the same story is told in words below. Some of the words have been left out—for example: Balloon is the word missing from the first line of the story. What you should do to win this contest is fill in all the missing words to fit the picture above. Send us the list of missing words, in their correct order, with a list of what you enjoy most in FLYING ACES, the three-in-one air magazine—the stories, the articles, or the model building section—and why.

#### Here's the Story:

The observer in the swaying basket of the observation  
 Took a hasty look above him as the roar of the  
 motor reached him. Seeing that the Allied ship was  
 in his direction, he notified the ground crew and  
 from the basket, trusting to the safety of his ever-ready  
 Above him, the pilot of the Allied ship sent a stream of  
 at the huge bag below him. As he dived nearer to the  
 a protecting enemy ship, which he recognized at once as a  
 came upon him, flying inverted, having just completed a  
 almost completely about the fast-descending  
 Bullets from this new antagonist whistled past his left wing  
 as he poured a stream of lead into the gas bag bearing the  
 of the German air corps on its side. He must destroy the  
 in spite of the new enemy ship and the second one  
 toward him from below. This latter ship, a German  
 had been bombing the highway in the distance, where a string of  
 were carrying supplies to the Front. Fortunately for the  
 of the First Allied ship, a lone ship recognized as a  
 by its arrangement of struts and guy wires, had seen the  
 and was roaring to help his brother pilot. The  
 now became more even, and after combatting the  
 enemy ships, the Allied planes took care of the  
 sending it down in flames to fall upon its  
 putting that also out of commission. The two Allied  
 flew back to their home drome, the victors in the

#### Don't Forget:

The winners of the contest will be judged by the correctness of their list of missing words and by their letters. All decisions by the judges will be final.

Be sure to mention in your letter the name and number of this contest, and the issue in which it appears. All answers on Missing Words Contest No. 16 must be mailed by the time the next issue of FLYING ACES is on sale. Send to

Missing Words Contest No. 16

FLYING ACES Magazine

67 West 44th St.

New York, N. Y.

Strange thumbed his trips, chandelled tightly. Hardly had he begun his climb when the mystery ship pitched down in a headlong dive. He sheered out, but the gruesome figure at the stick apparently had not seen him. The charred wings flashed past, vanished in the clouds. Engines roaring, the Nieuports plunged after the ship. Strange was whipping around to join them when a lightning premonition stabbed at his brain.

He rolled hastily. Green flame spread through the cloud directly below him as the Spad whirled over. The ship rolled again. The next moment a stream of emerald fire shot up in the space where he had been about to dive. It spread out in an oily pool, became a rounded mass and sank to earth.

## CHAPTER II

### THE SKELETON VANISHES!

WITH fervent thanks to a kind Providence, Strange turned and dived in the other direction. He came out of the clouds with fingers taut on his trips, ready to fire. Blazing like green meteors, the two Nieuports were falling, a thousand feet beneath. And circling above them, not two hundred feet from the Spad, was the fire-scorched mystery ship.

Strange's pulses hammered. With a lightning turn, he dove in at the side. The Vickers pounded as his fist clamped the trips. The chattering guns raked over the skeleton figure, on toward the nose of the ship.

There was a muffled roar, and the nose of the mystery plane dropped abruptly. Strange stood on his rudder, skidded with all his might. For a second he thought he would clear. Then with a crash, the wings collided and locked.

The shock threw Strange forward.

His head grazed one of the Vickers butts. He pulled himself up in the pit. The two ships were careening downward at increasing speed.

With a violent wrench, the two ships pulled apart. Strange jammed the stick to one side as the black ship slued into a spin. The Hisso was dead. He had cut it off at the moment of the collision. The Spad fell off, started to spin. He dropped the other wing in a hasty slip. The plane moaned down, the crippled wing trembling and jerking. A thousand feet below, the mystery ship was wobbling toward the river edge of the drome. It seemed to be partly under control.

The greenish fire was already diminishing. Smoke began to veil the burned part of the drome. Strange saw that all the hangars and barracks on the main side had been destroyed. Only a shop and a small Bessoneau hangar, across the field and close to the river, remained untouched. The black ship was lurching down in that direction. Strange carefully ruddered to slip after it. Suddenly, wings screeched above him. He threw back his head, saw two Fokker tripes hurtling down at him.

Spandau eyes winked evilly as he stared upward. Tracers crackled into the right wing, raked over the cowl.

He hit the switch. It probably meant a quicker finish, but anything was better than sitting there and letting that devil pick him off.

The prop was still turning over under the force of his plunge. The Hisso caught, roared to life. Strange jammed the throttle open, banked on the good wing. Spandau slugs were crashing into the Spad from two directions. As the Spad banked, Strange hurriedly crossed controls. With a vicious snap, the ship went onto its back.

A gray shadow flashed past as the first tripe overshot. Strange kicked hard as the second ship drilled in. The Spad skidded wildly. The second Boche zoomed in frantic haste as the Spad plunged toward him. Strange snapped the trips against the stick. Vickers lead spewed up at the climbing tripe. He could see the tracers stitch a fiery line under the German ship's belly.

The tripe stood on its tail, whip-stalled. Missing the Spad by less than five feet, it plummeted for the ground. Fire spouted up as it struck.

Strange battled the Spad into a shuddering turn. The second Boche came thundering across the sky. Guns still pounding, Strange booted the rudder. The Vickers thrashed out a murderous blast, their tracers tangling the death-tipped streaks from the clattering Spandaus. The half-wrecked wing pulled to one side and the Spad slued off drunkenly. Nose-down, the Fokker screamed after it. Bullets hammered into the roaring Hispano. Something cracked loudly. Strange cut the switch as black smoke gushed from under the cowl.

The lone canvas hangar loomed up before him. He tried to swerve, but the Spad was out of control. The right wing tip struck the canvas side. Like a pin-wheel, the ship whirled around. Strange hurled his goggles away, threw his arm before his face. With a grating roar, the already crumpled left wing hit the earth. The ship went over and onto its nose. Strange had a flashing glimpse of the river close by. Then came the crash.

The next thing he knew, he was sliding head-first down the muddy bank. He caught at a clump of brush. It tore from his hand, but slowed his fall. He stopped, hands outstretched, his face almost in the water. He caught his breath, and started to clamber up the bank.

Spandaus rattled from the second tripe. Strange flattened against the bank. The Fokker howled down, guns glazing, but the sparkling tracers did not stab toward the spot where he lay. He raised his head cautiously as the German zoomed. The wrecked Spad was twenty yards away, one broken wing sticking up, silhouetted against the waning green fire across the drome. The tripe snarled down again, raked the wreckage with a long, furious burst. Hidden in the brush at the edge of the bank, Strange grimly watched.

THIS time the Boche seemed satisfied. He pulled up, circled away from the river. From somewhere beyond Strange's range of vision a blue rocket flared skyward. Instantly the tripe nosed down, Mercedes idling. Strange hauled himself up to firm ground, gazed toward the southern edge of the field. The Fokker was gliding in that direction, as though to land.

From somewhere midway there showed a brief flash of light, as though a small torch had been lit. It whirled through an arc, ending by a shapeless hulk on the ground. Three seconds later, there was a puff of fire, normal in color. It was lost at once in

# In the Next Issue of FLYING ACES

## Fiction

"Philip Strange" Novel by Keyhoe  
"Kerry Keen" Mystery by Whitehouse  
"Phineas" Mirthquake by Archibald  
and Others

## Fact

Pursuit Aviation Today, by Lewis  
Flying the Transatlantic Air Mail  
Mystery Fighters of Today

## Model Building

Plans for the new Northrop XFT-1,  
the Flying Aces Hi-Climb R.O.G.  
and Others

In the  
September FLYING ACES

On Sale  
July 24th



a terrific explosion. Then once again Strange saw that queer greenish smoke which had already puzzled him.

He started along the river bank, then dropped his hand to his hip. The Fokker had swung around to the east of that greenish smoke, and was landing in the darker area near him. He unbuttoned his holster flap, took out his .45, discarding his muddy gloves.

The Fokker stopped about three hundred feet from him. As he crept along, half-shielded by the brush and small trees at the side of the river, he saw the pilot jump to the ground and start back of his ship. Suddenly, from the highway far across the drome, a beam of white light began to sweep the field. It passed over the spot where the explosion had occurred, revealing a small crater from which green smoke was rising.

Something lay on the ground between the crater and the Fokker. Strange felt his scalp tug as he saw the fire that played about that blackened skeleton figure. The thing was still burning, yet it had managed to crawl that distance from where the charred ship had exploded!

The Fokker pilot had thrown himself prostrate as the beam from the searchlight truck swept near him. The light moved on, spotted the triplane. The beam shifted as the truck swung off the road and onto the field. The German pilot sprang up, raced back toward his ship. Strange dashed forward to intercept him. The Boche saw him, ran for the other side of the Fokker. Strange lifted the Colt, took deliberate aim. The heavy pistol roared. The German stumbled as the .45 slug went into his thigh.

Strange reached him in a few seconds. The Boche was trying to drag himself to the ship. He collapsed suddenly. Strange switched off the Mercedes and hastily searched the unconscious German. He found nothing of importance. He made a rough tourniquet about the man's leg to stop the swift flow of blood, then went toward the spot where he had seen the skeleton.

The searchlight from the truck was sweeping about the field as the car rumbled toward the Fokker. Strange looked eagerly toward the place where the skeleton had lain. He jerked to a halt, staring about him, as he realized that the gruesome figure was gone.

He bent over the spot, searching the ground. A bony footprint showed in the soft earth. As he searched for another print, the truck searchlight spotted him. The klaxon horn burst into a raucous command to halt. Instead, he started at double-quick for the river bank, following that sinister trail. His eyes lit up, green as the emerald fire which had descended from out of the night. The thing was heading for the Bessoneau hangar.

The klaxon squawked angrily; then a rifle spoke with a vicious crack. Strange dived down the bank as a bullet ploughed mud near his feet. The bank cut off the beam of light, leaving semi-darkness along the river. He was crawling along toward the hangar

when something moved in the gloom. Streaks of greenish fire showed through a clump of tangled brush. Then a black and bony arm shot out toward Strange's gun.

He jumped backward, squeezed the trigger. A curiously muffled snarl came from the charred jaws of the skeleton. Hideous arms outstretched, it charged through the brush. Strange pumped two more shots. The skeleton's left

### Flying Aces Stratosphere Pursuit

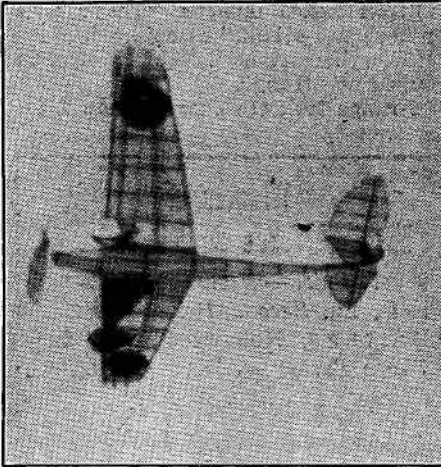

Turn to Page 40 for plans of the FLYING ACES Stratosphere Pursuit Ship pictured above. It's a great model!

hand jerked up toward its blackened ribs.

Then the grisly figure lurched forward again. Strange slipped, and went down in the mud. The skeleton lunged down after him. With all his might, Strange swung the .45. The heavy automatic crashed against the figure's black skull. There was a sudden, hissing sound. The skeleton jumped back.

As Strange sprang to his feet, he heard the rumble of the searchlight truck. He gave a shout. The skeleton whirled, and a bony first cracked on Strange's jaw. Caught off balance, he tumbled backward and slid down the bank. As he lay there, half-stunned, he heard the squash of feet in the mud. The roar of the truck motor grew louder, then dropped abruptly in volume. Strange got to his knees, shook his head to clear away his daze.

The skeleton had vanished!

SEVERAL doughboys appeared along the river bank as he stared around. A stocky sergeant lifted his pistol.

"Come on out of there, Fritzy!"

Strange climbed up the slope, peeled off his flying-coat and revealed his captain's bars. The sergeant started to lower his gun, then paused suspiciously.

"How do I know ya ain't a Kraut spy?" he demanded.

"I can identify myself at Pierrefitte," snapped Strange. "But first, get that truck over here so the light will spot the bank."

"What's th' idea?" growled the non-com.

"Move!" grated Strange. His green eyes bored into the man with suddenly hypnotic power. The sergeant stiffened. Like a man in a dream, he mumbled an order. The staring doughboys hur-

riedly brought the truck to the edge of the bank, tilted the searchlight down.

Strange shot a glance along the slope. The huge footprints of the skeleton showed plainly in the mud.

The searchlight pivoted. A startled look came into Strange's face. The tracks led down to the river and disappeared. He gazed out over the muddy surface.

"Must have slipped and fallen in," muttered Strange.

The sergeant's face, ash-white in the glare, twitched toward him.

"Ya mean ya saw the thing that made them tracks?" he whispered.

The sputter of a rapidly approaching motorcycle prevented Strange from answering. He turned as the machine braked to a stop, a few yards away. A thick-set man in the uniform of a colonel jumped from the side-car. As the glow of the searchlight fell on his square, bulldog features, Strange saw that it was Jordan, the chief of G-2, Jordan strode toward the non-com, not at first recognizing Strange.

"So you got that Boche pilot?"

"Yes, sir," rumbled the sergeant, saluting. "I got a man guarding him back at the plane."

"Then who's this—" Jordan broke off as he saw Strange's mud-spattered face.

"It's all right. I know him." Jordan hastily drew Strange aside. "What do you know about this hellish business?" he said in a low voice.

Strange silently pointed down the bank. Jordan went rigid as he saw the skeleton footprints.

"Good God!" he whispered. "Another one!"

"Then you've seen others?"

"Only the one that dived at the drome, but they've already been reported from two other places tonight. A whole flight of the 81st was burned out of the sky an hour ago, and a supply dump near Cources was blotted out just like this drome."

"I have a third report," Strange said grimly. He told Jordan what he had discovered at the Forêt des Rogues station. Jordan's bulldog face lost its hardness for a moment.

"Poor Lorton," he said huskily.

Strange was staring down at the river. "When did you first hear about the skeletons?" he asked.

"Three nights ago," said Jordan. "There was a wild story from one of the French outfits. Three of their pilots were on bat patrol. One came back, raving about a black skeleton in a blazing ship. Said the skeleton had downed the other two ships in flames. Everybody thought he was mad. Then tonight we heard these other reports, and I myself saw that devil drop out of the green ball of fire."

"So did I," Strange muttered. "I thought at first it was the third Nieuport."

"No," said Jordan. "That first ship got away. I saw it glide toward the courier field on the other side of the village."

"How long will it take to get boats and gear to drag the river?" Strange

asked abruptly. His face was tense.

"An hour, maybe less."

"Let's get to a phone, then. When we find that skeleton, we'll know the answer to the whole thing."

JORDAN gave orders for the searchlight to be kept trained on the river. Strange went over to the Fokker. The German pilot was still unconscious.

"Bandage that wound a little better," he told the doughboy on guard.

He went back to where he had dropped his flying-coat; then he and Jordan took the motorcycle and hurried to the highway. Army cars from Pierrefitte were beginning to arrive at the scene of the holocaust. First-aid squads started to search for survivors who might have been overcome by the heat and smoke. Strange halted an ambulance.

"There's a wounded German over by that Fokker," he told the driver. "Get him to the dressing-station in the village and then call Corps G-2 and report."

The ambulance swung across the drome. Strange looked down at Jordan in the side-car. "By the way, what mission was Lorton on?" he asked.

"We'd heard rumors of a concentration somewhere across from this sector. Lorton was trying to spot it so we could pull an attack with the new 'Strafe-Wing.'"

"He sent you a message asking for help?"

"Yes, and he specifically asked for you. Said he was on the trail of something, but couldn't make it alone."

The road led around the village, through a wooded lane. Strange knew the place perfectly. He turned off toward the meadow which served as a courier field for the G-2 station.

"What's the matter with the main entrance?" grunted Jordan.

"I want to ask that Nieuport pilot if he saw anything above that green fire when he zoomed up," Strange explained.

The Nieuport was there, drawn up near the trees at the foot of a ridge, but the pilot had gone.

"We can question him later," said Strange. He followed Jordan to the camouflaged passage exit. A sentry stepped from the gloom, saluted as he recognized the colonel. Strange and Jordan entered a concrete-lined tunnel.

The dugout was a large chamber divided into several rooms. Three or four officers were talking excitedly in the passage which led to the main entrance. A portly major gave an exclamation at sight of the G-2 chief.

"Colonel Jordan! We heard you'd been killed in that fire at the 53rd!"

"Just missed me, Bissel," Jordan grunted. He motioned the major to follow him and Strange into one of the offices. "Anything else happened since I left?"

"Chaumont's been trying to get you. They sounded as though they actually believe this crazy story about flying skeletons."

"It's true!" exploded Jordan. Then an angry color came into his belligerent

face. "And yet, by God, it can't be! It's some Boche trick—but how they're doing it is beyond me."

Bissel looked at him, bewildered. Jordan made an impatient gesture.

"Never mind. I've a rush job I want done." He gave instructions for having the river dragged. Bissel was hurrying out when Strange stopped him.

"Just a second, major. I want a wireless transmitter and receiver put in a captured Fokker out there by the river. Can you push it through by midnight?"

Bissel looked dubious. "That's only an hour and a half," he objected.

"How important is this?" Jordan rapped at Strange.

Strange took the charred map from

### Winners of Missing Words Contest No. 14

*First Prize*—WILLIAM H. SOPP, Erie, Pa. *Second Prize* — BILLY WHILES, Hollywood, Cal. *And Three Prizes* — WALTER FAGAN, Chicago, Ill., GEO. W. ALLEN, Fort Smith, Ark., and FRANCIS HOLMES, Montpelier, Vermont.

his muddy flying-coat.

"If I'm right, the base for those skeletons is somewhere on the extension of that course-line. Lorton had it marked definitely, but that part was burned. With a wireless set in that Fokker, I can fly that course and signal back when I spot the place."

Jordan's bulldog face lit up. "Hell, we can send the whole 'Strafe Wing' and wipe out those devils!"

"They'd be picked up by sound-rangers as soon as they crossed the lines," said Strange. "No, I'll go alone."

Jordan gestured toward Bissel. "Have the wireless set put in that Fokker, pronto," he ordered.

BISSEL lumbered out. Jordan closed the door, sat down heavily at his desk.

"Strange, this thing's got me stumped. Damned if I'll believe a skeleton can fly a plane, but no human being could live through that fire." He stopped short, smacked one fist onto the desk. "A robot! That's the answer—those skeletons must be machines!"

Strange smiled grimly. "And I suppose somebody over in Germany pressed a button to make that one chase me down the river bank," he commented.

"I'm not joking," snapped the G-2 colonel. "It's the only thing that fits. Your bullets wouldn't stop it, and that green fire didn't burn it."

"No, colonel," Strange said soberly. "The thing that jumped me was alive, very much so."

"Alive! How could a man breathe inside that ball of fire, let alone keep from burning?"

Strange stared at him, then suddenly snapped his fingers.

"You've hit it!"

"So you admit—"

A rap at the door interrupted him. "Come in," he barked.

Bissel came in hastily. "Colonel, there's an ambulance driver outside who's seen one of the skeletons!"

Jordan jumped to his feet. "Where was it?"

"Close to the river road. They were bringing that Fokker pilot in by the short-cut—"

Without waiting to hear the rest, Strange hurried to the main entrance. Under the camouflage netting which screened the approach to the dugout, an Army ambulance was standing. Several G-2 officers were gathered around a wild-eyed driver and a big, red-haired Air Service captain.

"I tell yuh it would've killed me, if it hadn't been for th' captain here," the driver was saying tensely.

Strange pushed through the little group. "Where did this happen?" he asked crisply.

"Right where th' old road turns away from th' river," the driver told him.

Strange turned to one of the Intelligence lieutenants. "Get a searching party with torches and automatic rifles," he ordered. "Cover every inch of that ground."

The lieutenant hurried away. Strange beckoned to the driver and the Air Service captain.

"Come below. I want to ask you some questions."

"What about that Heinie pilot inside?" The driver jerked his thumb toward the ambulance. "He's hurt bad."

Strange went to the rear of the machine.

"If he's conscious, I—" He stopped, slowly turned. "This man's dead. He's been shot through the heart."

The driver's jaw dropped. Then he followed Strange's eyes toward a bullet-hole in the side of the ambulance.

"One o' Jake's bullets must've gone wild," he said dazedly.

"Jake was your stretcher-man?" Strange demanded.

"Yes, sir." The driver swallowed hard. "Th'—th' skeleton got him, but he fired five shots at it, and this must've been one of 'em."

Strange motioned him toward the dugout entrance. The red-haired captain limped after them. Colonel Jordan and Bissel were just coming up the steps. They turned back, and the five men went down to Jordan's temporary office. The Air Service captain started as he saw Strange's bruised face.

"You encountered one of those things, too?" he exclaimed.

"Yes—the same one," Strange answered.

"But you said that skeleton was at the bottom of the river," objected Jordan.

"He didn't stay there," Strange returned sourly. He took a pad from Jordan's desk, gestured to the red-haired captain. "I'll take your story first—but sit down. You look rather shaky."

"I am," muttered the other. "If you came as close to death at that thing's

hands as I did, you can understand—" Strange nodded, as the other man took a chair.

"I understand, all right. Maybe a little bracer will help." He reached back and opened a drawer.

Jordan scowled. "You know I don't keep liquor in there," he said.

"But you keep this." The snub-nosed .38 seemed to leap into Strange's fingers. He smiled coolly down the barrel at the red-haired man. "And now, von Wolfe, I'll trouble you for that little toy up your sleeve."

### CHAPTER III

#### GREEN FLAMES

A STUNNED look came into the other man's face; then he sprang to his feet.

"What's the meaning of this?" he roared. "I'm an officer in the Air Service." He whipped his right arm downward, and a small Mauser pistol dropped into sight from his sleeve. The .38 cracked savagely against his wrist. The German gave a howl, and the pistol clattered upon the concrete. Strange shoved the weapon aside with the toe of his boot, not taking his eyes from the captive. Murderous fury flamed into the other man's eyes.

"You *Teufel!*" he snarled. "They told me you were dead!"

"Sorry to disappoint you, *Herr Rittmeister*," Strange said pleasantly.

Jordan and the others were staring open-mouthed.

"You mean this is Heinrich von Wolfe, the Bavarian ace?" exclaimed the G-2 colonel.

"Minus his beard and mustache," nodded Strange. He smiled ironically at the big German. "You should have dyed your hair more carefully, von Wolfe. I wasn't quite sure until you sat down under the light."

The veins stood out in the spy's powerful neck, but he forced back his rage with a visible effort.

"I admit my identity," he said coldly to Jordan. "But I do not have to submit to insults from this swine."

"Keep your shirt on," growled Jordan. "I'll tell you what you have to submit to around here." He looked at Strange. "How does he fit into this skeleton business?"

"Very smoothly, I think." Strange took a step forward, prodded the muzzle of the .38 just under von Wolfe's heart. The German winced, stifled a grunt of pain. "So you felt those shots of mine! I wonder where you left your bony friend hidden."

Von Wolfe glowered at him silently. Strange jerked his head toward the ambulance driver.

"Search the prisoner while I cover him."

"Hold on," interposed Jordan. "How do you know this man isn't working with von Wolfe?"

"Thinking of the dead Boche pilot? No, von Wolfe killed him after he'd murdered the stretcher-man and dazed the driver."

"But it was th' skeleton that knocked me out," blurted the driver. "Th' cap-

tain—I mean, this Kraut here—never showed up till later."

"I begin to get it," said Jordan to Strange. "But how he can turn himself into a skeleton is beyond me."

He was interrupted by the entrance of an orderly.

"Major Bissel," the man said, "somebody's on the wire, asking about a boat detail."

"We won't need that now," Strange told Bissel. As the major went out with the orderly, Strange motioned the ambulance driver to proceed with the search of von Wolfe. Orders in the name of Captain John Anderson, and written on U.S. Air Service paper, were found, along with French money and some American cigarettes.

"H-m-m," said Strange, "all set in case you were forced down, *nicht wahr?* . . . Hello, what's that?"

The driver had produced a small black note-book. Von Wolfe's hard face darkened as he saw it. Strange handed the .38 to Jordan, and eagerly turned the pages.

"Special code!" He turned quickly to the door. "I'm going to see if the wireless operator has caught any of this tonight."

"Okay," grunted Jordan. "Meantime, I'll see if I can persuade this big lum-mox to do a little talking."

There were two operators constantly on duty at the G-2 station, one listening for German messages, the other transmitting and receiving official traffic through a remote-control set. Strange went into the first operator's cubicle. The man on watch looked at the code-key in the black note-book, and gave a quick affirmative to Strange's question.

"We've been catching stuff like that for three nights, captain. Haven't been able to break the cipher."

"Let me see the file," said Strange.

FIVE minutes later, he hurried out of the cubicle. He was passing through the remote-control room when his ears caught the buzz of an outgoing message. He stiffened. It was von Wolfe's code!

"Hold that message!" he rasped at the operator.

"But Colonel Jordan ordered it rushed—"

Strange snatched the scribbled note from the operator's desk, and dashed into the passage. He was whirling toward Jordan's room when a shot crashed. With Bissel and two or three others at his heels, he raced down the passage. Sounds of a scuffle came from Jordan's office. Strange threw open the door.

The ambulance driver lay on the floor, a bullet hole in his head. Jordan was bent back over his desk, trying desperately to wrench the .38 from von Wolfe's hand. As Strange leaped into the room, the spy jerked the weapon free. Strange dived low. One hand flashed up to the German's arm. A vicious twist, and the spy catapulted forward onto his face. Strange stamped down fiercely on the fingers that held the gun. There was a deep groan.

A minute later von Wolfe was again a prisoner, held by two armed sentries. Jordan, breathing heavily, turned from the glaring German to Strange.

"The rat pulled a trick on me— whirled the driver in front of him before I could shoot. In the scuffle, he knocked the gun out of my hand and cracked me on the head. When I came around, he had the driver covered and was putting down the phone. I tried to jump him. He fired, and killed that poor kid—" Jordan's voice thickened, and he turned with sudden fury. "Get him out of here before I forget myself and give him the same dose."

Von Wolfe was hustled out of the room. Strange waited until the body of the ambulance driver had been removed, then told Jordan of the intercepted message.

"I'm afraid most of it went out," he said glumly, "but at least we can find what he sent."

He bent over the message and the code-book.

"He's a cold-blooded devil," muttered Jordan. "He must have planned that trick to get in here and send that message."

"Probably seized the first opportunity," said Strange. His green eyes were flying over the code groups. He wrote down a word, worked on for several minutes. Suddenly he jumped to his feet with an exclamation.

"What is it?" barked Jordan.

"We've got to abandon this place! Every one will be burned alive!"

One look at Strange's tense face and Jordan ran for the passage. His fierce voice echoed through the dugout headquarters. In a few seconds the place was in an uproar. Startled Intelligence men dashed for the main steps. Von Wolfe, guarded by two men, was hurried toward the entrance. A look of sullen ferocity came into his eyes as he saw Strange.

Officers, G-2 clerks, and operators were swarming up the concrete steps. As the last man went up, Colonel Jordan spun around to Strange.

"That map! It's back in my office."

"I can remember the course," clipped Strange.

Jordan and he were starting up to the entry when a frightened yell came from above. The sound was lost in the howl of diving ships.

Strange took the steps three at a time. A green radiance was lighting the ground beyond the camouflage nets. He ran from under the canvas, then stopped in consternation.

A curtain of green fire was blazing down from the sky!

AS Strange halted, two spots of emerald light appeared in the night, to the north and west of the station. They spread into vivid green streaks, curved to meet the settling curtain of fire. By the rapidly growing brilliance, he could see the blurred shapes of planes just ahead of those thickening streaks. The weird greenish fire seemed to sput from the tail of each ship. The streaks were now turning into still other curtains.

The terrified G-2 men were fleeing toward the largest gap between the settling walls of fire. Suddenly a fire-blackened plane hurtled out of the night. A blazing emerald stream shot back from its tail. The black ship zoomed, and another fiery mass gushed down toward the ground. Five men vanished in the furious blaze. Strange saw three more wilt to the ground as the terrific heat overcame them. He whirled and ran back toward the dug-out.

The ambulance was careening toward the only gap now left in the flaming green curtain. One man fell from the running-board, and ran after the car, screaming. A hand closed convulsively on Strange's arm.

"They'll never make it!" came Jordan's hoarse cry.

Even as he spoke, a mass of fire came roaring down to fill the breach. The ambulance swerved crazily, crashed into a tree. The next second, it was lost in the blinding green blaze. The fearful heat drove Strange and Jordan back, gasping for breath. Strange clutched at the G-2 chief.

"Back into the dugout! It's the only chance now!"

He fell over a body sprawled on the ground near the nettings. As he lurched to his feet, he saw blood welling from a hole in the man's left side.

"It's one of von Wolfe's guards," Jordan rasped.

Strange jabbed a finger toward a burly figure running, doubled over, down the wooded slope.

"He's making for the meadow! They'll land and pick him up!"

The screech of wings drowned the last few words. He flung his head back, stared upward. One of the flame-ships was pitching straight down at them. By the dazzling glare from all sides, he could see the blackened skull of a skeleton leering over the cowl.

"Into the dugout!" he shouted.

Jordan dashed down the steps. As Strange ran under the netting, he had a lightning glimpse of the flame-ship zooming steeply. Just as he reached the steps, a green hell seemed to explode above him. Blistering heat swept down at him. He plunged down the concrete steps. The lights had gone out as the power line burned through, but the fierce glare above showed the passage clearly.

"The other tunnel!" he gasped at Jordan. Panting for breath, he staggered after the colonel. His lungs seemed about to burst. The heat was like the blast from an open furnace door. He reached the turn, stumbled over Jordan. The colonel was crawling toward the door to the rear passage. Strange tugged at the door-handle, sucked in cool air as the door swung open. It took all his strength to drag Jordan into the passage. He sagged against the door, jammed it shut.

For a moment he hung there, till the increasing heat brought him back to their peril. He reached down, gripped Jordan's shoulder.

"We've got to make the other end,"

he said thickly. "That stuff may burn through the door."

The next half-minute seemed an eternity. Stumbling, sometimes crawling on hands and knees through the blackness, they went down the winding tunnel. Gradually, the heat from in back of them lessened. A few seconds later, they came to the turn near the exit.

Greenish light showed through the camouflaged tarpaulin which covered the hole. The sentry had fled. Strange cautiously pulled the cloth aside. Against the ring of fire which ran across the center of the meadow, he saw flame-ships landing. Von Wolfe's powerful figure was silhouetted where he stood under a tree. The first flame-ship taxied in toward the spot. Von Wolfe raised his right arm, moved it in a circle above his head. The skeleton figure in the pit of the flame-ship sent a rocket flaring skyward. In a few moments, a Halberstadt two-seater slipped down in the fire-circled area, carefully keeping away from the ring of green fire.

THE leading flame-ship came to a stop as von Wolfe strode out from the trees. Jordan peered over Strange's shoulder at the seemingly fire-charred plane.

"How the devil do those burned crates stay in the air?" he muttered.

"They're undoubtedly metal from prop to rudder—and fireproofed, like those rats that fly them."

Jordan stared at the weird skeleton pilot who had stepped to the ground.

"Good Lord, he's on fire right now!"

"Look again. Those black bones are painted against a phosphorescent background that looks like flame."

"By Heaven, you're right! But that skull—"

"Moulded out of metal, and probably hooked onto the suit like a diver's helmet. It would almost have to be, in order to hold the oxygen."

"Oxygen?" said Jordan.

"Yes. You're the one that made me think of it, with that remark about a man's not being able to breathe inside that green fire. That's why von Wolfe walked into the river. He knew he could turn on his oxygen and walk along the bottom till he was far enough away to walk out again."

Jordan swore under his breath. "It's a clever stunt—but I still can't see why they don't catch fire."

"The suits must be asbestos, and sprayed with ammonium phosphate or some other fireproofing before they're used each time. I've a hunch the ships are sprayed, too. With that, and their speed, they can dive through one of those fire-clouds without any damage but getting smoked up. Also, the helmets and suits must be bullet-proof, even the glass in the eye-sockets. They're practically invulnerable, unless you hit a prop by a lucky shot as I did."

"Then how will we ever wipe them out?" grated Jordan.

"Do what Lorton said," Strange replied grimly. He tensed as he saw von

Wolfe look back toward the slope. The skeleton pilot beside him pointed to the top of the ridge, and the big German nodded.

"He thinks we've all been wiped out," Jordan whispered. "Thank God he didn't know about this other exit."

Von Wolfe turned and hurried toward the Halberstadt. The green fire was spreading through the underbrush, fading to ordinary color as grass and bush flared up. Strange lifted the tarpaulin and stepped outside, under the trees.

"What are you going to do?" Jordan asked tautly.

"Take that Nieuport before the fire gets to it. I'm going to follow those butchers."

"You're mad, Strange! They'll burn you down."

"Not if they don't see me. I know the course to their base—about 96 degrees—and I can hang back and still not lose them."

The Halberstadt roared across the meadow, banked sharply away from the fire and soared into the night. The flame-ships which had landed raced up and joined others which had circled above the field. Strange ran toward the Nieuport, close to which the flames were rapidly creeping. Jordan panted after him.

"There's no wireless in that ship," he said, breathlessly. "You can't send back word—"

"I'll bring it back!" snapped Strange. He set the switch, ran to the prop. The Hispano caught at his second throw. He wheeled to the G-2 chief. "That ring of fire is dying, there at the south. When you can get through, have word flashed for the Strafe-Wing to stand by for a bombing raid. I'll bring you the location of that base—or I won't be back!"

## CHAPTER IV

### DEATH UNDERGROUND

LOCKING the stick between his knees, Strange beat his cold hands together. Without flying-gear, it was bitterly cold at ten thousand feet. He slitted his eyes against the prop blast, stared ahead into the night. He had lost sight of the German ships after crossing the Front, but ten minutes of trailing them had proved that his course was correct.

A minute passed; then he caught the faint flare of exhaust stacks well on his right. He eased the throttle back and warily turned toward the other plane. Abruptly, the red and yellow tongues of fire ceased to spit from the other ship's motor. Strange cut his own switch, thinking he had been sighted.

Blurred wings showed for a second below him, then were swallowed up in the night. Strange held the Nieuport close to stalling speed, listening intently. He could hear no drone of motors. Spiraling slowly, he began to descend. Either he had lost the Boche ships or they were landing in the darkness.

The Nieuport moaned earthward

through the blackness. After a minute it slipped into the dank mist of a cloud. Strange swore to himself. The flame-ships could have glided under the clouds and landed by this time. That would mean that their flares at the secret base would be extinguished unless he moved quickly.

As the ship plunged into clear air, he swiftly surveyed the area below. The lights of a tiny village were visible a few miles to the north. Farther east, the headlights of an automobile illuminated the road along which it was speeding. All else was a black expanse.

The altimeter showed three thousand feet. Strange switched on the motor, still berating himself for losing the Germans. Suddenly, a red pinpoint of light winked from the darkness beneath. Instinctively, he jerked the throttle to idling. Then, gliding as silently as possible, he turned toward the blinking light. The wind and cold air brought tears to his unprotected eyes. He brushed them aside, trying to catch the rapid flickering of the red light.

It was obviously a message, perhaps a signal guiding von Wolfe's raiders back to their secret lair . . .

For the second time that night, a sudden feeling of danger swept over Strange. His fingers tensed about the gun-trips. Above the drone of the Hispano came a static roar; then a parachute flare blossomed directly overhead.

Strange chandelled, engine at full gun. Two warming bursts flamed from the cold Vickers. Diving headlong, three Fokker tripes plunged for the zooming ship. Strange was almost out from under the dazzling brilliance of the flare. One of the tripes slashed down in his path, with Spandaus fiercely blasting. Strange hurled the Nieuport onto its tips. The tripe roared by, pulled up in a furious climb. Strange's cold hand snapped the trips together.

Thin red streaks lanced from the snarling Vickers. The Boche skidded madly as the tracers ripped through his cowl. Crouched back of his guns, Strange rocked the Nieuport's rudder. Greasy smoke puffed from the Fokker's nose. Too late, the other tripes charged to the first man's aid.

As Strange rolled out of a murderous burst, the smoking tripe burst into flames. The others darted in venomously. Slugs gouged the turtleback, a foot from Strange's head. Spandau lead hammered across his tail, crept forward. He kicked out swiftly, and sent the Nieuport roaring up as though for a loop.

The straining ship zoomed above the flare. With a violent twist, Strange rolled and changed direction. The first of the two remaining tripes shot up in a following loop. Blinded by the sudden emergence in darkness, he curved on through. Strange rammed the stick forward, dropped on the Boche like a thunderbolt. The pilot jerked around frenziedly as tracers smoked past his head. Then the Vickers torrent chopped him down in the pit. The Fokker nosed over and screamed down into the night.

The last German plunged insanely at

Strange. A stream of Spandau lead tore through the lower right wing. By the light of the flare, now above the two ships, Strange saw the leading edge crumple. As he hastily sheered out, fabric tore from the panel, whipped back in the wind. Another strip ripped loose, baring the slender ribs. The wing began to flutter.

Strange flashed a glance at the ground. The Nieuport was finished; even now it was shedding more fabric. He would be lucky if the wing held long enough for a landing. The fight had taken him down to a thousand feet. Rolling hills and dark patches of forest stretched away beneath. He had a glimpse of a clearing at the side of which stood a lonely chateau. It offered the only landing spot in range.

**T**HE Fokker had zoomed for another plunge at him. He saw it coming from the dark, coffin nose steeply tilted. With a grim disregard for the half-stripped wing, Strange snapped the Nieuport around. Defiantly, the Vickers blazed toward the hurtling triplane. The Boche kicked sidewise in his dive, corkscrewed around with Spandaus pounding. Their tracers crossed, drilled through the eddying smoke.

The Nieuport lurched, fell off to the right. Fiercely, the German pounced. A line of black dots raced over Strange's cowl. Shattered glass fell from the instrument dials.

Strange flung himself out of the crackling tracers' path. The Boche was closing triumphantly for the kill. Strange's cold hand tightened on the stick. The Nieuport's nose came up, whipped around in a snap to the left. Only a second—barely a six-round burst from the panting guns—but that burst was like a sword, gashing the German's throat.

Blood spurted out, and the pilot's head lolled on his slumping shoulders. The tripe roared on, with a dead man in its pit.

A tree-top flashed under the Nieuport's wheels. Strange jammed the left wing down, slipped toward the clearing. Twenty feet from the ground, he jerked the drooping wing upward. The right wing tip raked the earth. Strange cut the switch, hauled the stick to his belt. There was a crackling of ribs and spars, and the Nieuport ground-looped wildly. For a second it seemed that the plane would go over. Then the landing-gear collapsed, and the ship jolted to a stop.

Strange was out of the pit in a split second. He had cracked up within a hundred yards of the chateau. If this was where the red signal-light had appeared, there would probably be men after him at once. He ran for the nearest trees, tugging from his belt the .38 he had retrieved from von Wolfe.

The third tripe was still in the air, thundering somewhere up in the night. The flare was almost burned out, and he could not see the pilotless Fokker. He looked around anxiously. There was no sign of the flame-ships. The chateau was dark. Perhaps this place was deserted, after all.

Even so, he was in a tight spot. There would be a searching party looking for him. Without a ship, he was helpless to get word back to Jordan,<sup>5</sup> even if he had known more than the approximate location of von Wolfe's hiding-place.

Then he remembered the road on which he had seen the car. There would be other cars passing along that highway. If he could hold up a German officer and take his uniform, he might get to the nearest Boche *Jagdstaffel* and escape with a ship. He started along the edge of the woods, pushing in deeper to skirt the chateau. He was within a hundred feet of the building when the roar of the unmanned Fokker became louder.

He stared up between the trees. It sounded as though the ship were in a power spin or a dive. There was something gruesome about the thought of that plane flying with a dead man in the cockpit. It seemed to be headed down at the clearing.

The roar of the Mercedes rose to a frightful bellow. Then with a mighty crash the Fokker struck, back in the woods. Flame showed through the trees, vaguely lighting the place where Strange stood.

A movement at one of the upper windows of the chateau made him step back hurriedly into the shadow. Something glistened from the window. Peering cautiously around the trunk of an oak tree, Strange saw a man in field-gray, with a pair of binoculars raised to his eyes.

The German was looking toward the spot where the Fokker had crashed. In a moment he turned, picked up a telephone.

"*Ja, Herr Rittmeister,*" Strange heard him say. "I was about—" The next few words were indistinct. "Yes, *Herr Rittmeister,* I am sure the Yankee burned with the plane. It burst into flames the instant it struck."

Strange tensed. The observer had mistaken the Fokker for his Nieuport. Evidently the man had not seen the Nieuport land in the darkened clearing.

"No other planes, *mein Herr,*" the German was reporting. "That swine downed two of our triplanes, and I am afraid the other was forced down in the woods . . . *Ja, I will keep watch.*"

He put down the phone, and turned again to the window. He focussed the glasses on the lessening flames from the tripe, then disappeared within the room.

Strange gazed at the chateau. A door at the rear was sagging from its hinges. Glass was gone from two lower windows. The whole place had an air of desolation. He waited several minutes, but the observer did not reappear, nor was there any sign of other Germans.

**A** GLEAM came into Strange's eyes. This deserted chateau was obviously a lookout post for the secret base. That meant that the base itself could not be far away. It was probably hidden under camouflage nets, somewhere in the woods. If he could capture this lone observer . . .

Gripping the .38, he stole under the trees until he was opposite the sagging door. The glow from the burning Fokker had almost died out. With a quick look at the upper window, he ran across the grass. He reached the château without being discovered. Stooping under a window, he cautiously looked inside.

A frown cut vertical lines between his eyebrows. The château was a veritable shell. There were no rooms. Uprights and cross-bracing, apparently of new lumber, supported an X-shaped platform where the second floor should have been. He could dimly see a flight of steps leading up to it.

His discovery brought an uneasiness he could not entirely analyze. He should have been relieved at finding evidence that there was but the one man in the building. But there was something peculiar about the erection of this dummy château. From the outside, or from the air, it would appear to be an old, abandoned house. But why had the Germans gone to such trouble?

A scuffling of feet on the platform drove the thought from his mind. He tiptoed to the door, and with infinite care, moved it an inch or two. The hinges did not squeak. Then he saw that they were new, though they had been treated to make them appear old. He slipped inside, crept toward the stairs. He was almost at the top when a board creaked loudly. Instantly, heavy boots clumped on the platform.

"*Wer ist es?*" came a guttural query. "Fokker pilot," mumbled Strange, in German. He reached the last step. "I was forced down—"

A flashlight shone suddenly, and the observer snarled under an oath. Strange leaped with the .38 lifted. The Boche sprang back with a yell. The pistol struck his arm, and the flashlight dropped to the platform. Boards clattered as the man dashed toward the phone by the window.

The glare from the flashlight had for the moment blinded Strange. As he ran after the German, his toe hooked a cleated board. He went to his knees, almost tumbling from the narrow platform. A gun spurted flame, and the bullet drilled the plank on which he had fallen. He fired toward the window as the Boche was briefly outlined. The man came down with a thud. The clatter of the phone striking the boards followed a second later.

Strange could see now. The German was clutching at his shoulder, his other hand fumbling for the gun he had dropped. A buzzer sounded harshly. As Strange snatched the German's gun from the platform, the man clawed the phone into his fingers.

"*Hilfe!*" he shouted frantically.

The butt of the .38 cracked against his head before he could say another word. Strange made sure that he was unconscious, then seized the flashlight and turned it on the phone. The wires ran down one of the uprights. He hurried down the steps, after thrusting the German's Luger into his hip pocket.

The fat was in the fire now, he

thought bitterly. He might have been able to force the truth out of that observer, but after that warning cry, there was no time. Von Wolfe would be rushing help from the base. The only chance was to see where the wires led.

He went rigid. The wires led through a hole in the floor—and not ten feet away, a trap-door was lifting upward!

A shaggy head appeared; then a hand flicked up with a pistol. Strange jumped back of the trap, the .38 raised. The other man half-turned as he saw the glow of the flash.

"Drop that gun!" Strange rasped.

"*Spion!*" the German cried. He fired wildly.

The .38 stabbed a thick pencil of flame toward the trap. An ugly black hole appeared in the German's forehead. He plunged out of sight.

SOMEWHERE below, a bell jangled amid an uproar of voices. The floor of the dummy château trembled, began to slant. Strange dashed toward the front entry. The floor must be hinged to drop into some kind of excavation. It was tilting toward the rear.

"Faster!" came a furious voice from somewhere beneath. The whirl of electric motors rose swiftly.

The floor was now tilted to almost thirty degrees. Strange threw himself down as he felt his feet slip. He was almost at the front doorway. The flash and the .38 had rolled down the sloping surface. He caught desperately at the door-jamb, hauled himself to the opening. Then in stunned amazement he looked downward.

Not the floor, but the whole building had been tilted upward. It was at least twenty feet to the ground. Light was streaming from underneath, revealing a gradually inclined ramp which led back under the structure.

The truth hit Strange with sickening force. The dummy structure had been built upon a huge cantilever door. That ramp was for planes. Von Wolfe's base was a subterranean drome!

Three skeleton figures ran up the ramp, followed by a dozen men in dungarees. Suddenly von Wolfe's voice bellowed above the clamor.

"Switch off the lights, you fools! There may be Allied planes above here."

One of the men in skeleton suits gave a yell as he saw Strange clinging to the door frame. Von Wolfe charged up the incline, an automatic in his hand. He fired just as the lights went out. Strange let go as a bullet chipped wood two inches from his head. Splinters dug into his hands as he slid down the tilted floor. He brought up with a jolt against the opened trap-door.

Faint luminance from a hooded lantern showed through the square hole. He saw a rope ladder dangling into the gloom. He was about to jump up and run for the rear doorway when he heard shouts from that direction. Men had run to the pivoted end of the great cantilever door. In a few seconds they would have him!

He gripped the edge of the trap and

lowered himself into the aperture. The rope ladder swayed and twisted as he went down. He came to the last rung, stared around desperately. Normally, the rope ladder would have touched the ramp. Now it hung high in the air. One of the blackened flame-ships stood at the bottom of the ramp, at the head of a line of planes. Strange started the ladder to swinging, then let himself down till he held the bottom rope.

The nose of the flame-ship was almost beneath him. He was swinging back, ready to let go on the return, when a figure sprang from the shadows. The man gave a hoarse cry. Strange let go his hold. Down he plunged. One flailing boot struck into the German's face. The man went over backward, his cry choked off in his throat. Strange hurtled down on top of him. Knocked senseless, the Boche lay in a twisted heap.

The impact had almost taken Strange's breath. He snatched the German pistol from his hip-pocket, expecting instant attack. Then he realized that his drop from the ladder had gone unseen by the rest. He crouched for a second, half under the wing of the first flame-ship.

To the rear of the ramp, everything was dark. He shot a glance up the slope. He could make out vague figures at the top of the ramp. Escape that way was impossible.

He crawled back under the wing of the second plane in the column. Suddenly voices sounded from the left. Five or six men ran toward the incline, one of them with a bluish lantern. Strange waited till they had passed, then crept around to the other side of the ship. There seemed to be less activity along the right side of the base. He felt his way along as fast as he could. A heavy Diesel engine rumbled somewhere ahead, muffling all other sounds.

The pistol, which Strange held poised for action, hit sharply against a vertical metal surface. He was feeling his way to one side when a voice boomed from the front of the underground drome.

"Stand by to lower the ramp cover!"

"Clear the ramp!" bawled another German.

Strange hastily edged around the thing which had blocked his passage. He had to find a hiding-place before the lights came on. His free hand slipped over what seemed to be a metal wall. It ended, and he stepped into the space beyond. Electric motors began to whirl, and he heard the harsh grind of gears. The huge cantilever span which covered the ramp was closing down into place. He was being shut in with von Wolfe's murderous crew!

HOODED lanterns bobbed in the gloom. He pressed still farther back in the darkness at the right. There must be supplies, fuel drums, something which would conceal him until he could get his bearings.

"Lights!" came a shouted command.

Strange wheeled, crouched close to the metal wall. A string of light bulbs near the foot of the ramp flashed up first. The glow revealed the metal wall

to be the side of a small, square room. A large pipe, covered with asbestos, ran from the top of the room into one of several large storage bins along the side of the base. The bins were in reality small rooms. The first was padlocked, but the second was not. Strange flicked a glance about him and backed toward the door.

He reached it just as the main lights went on. A quick jerk, and he was inside. There had been no one close by. Apparently he had not been seen. He waited tensely for several moments, then opened the door a fraction of an inch and looked out.

Two pilots in skeleton suits and a *Leutnant* in ordinary *Feldgrau* were coming from the direction of the ramp. The pilots had removed the skull helmets and were carrying them under their arms. One of them, a thin, sallow man, turned nervously to the others as they neared Strange's hiding-place.

"What if the spy gets away? We'll be trapped in this hell-hole!"

"*Quatsch!*" said the other pilot scornfully. "He hasn't a chance to escape. Von Wolfe will have a battalion of infantry beating the woods inside of thirty minutes."

"I wouldn't care to be in the Yankee's shoes when the *Rittmeister* gets him," muttered the thin German.

"You had better get busy thinking of an excuse for pulling out tonight," growled the other pilot.

"My tank release was stuck," the thin Boche mumbled.

The *Leutnant*, a red-faced man with a bull neck, eyed the pilot suspiciously. "I'll see what was wrong with it," he grunted, and swung toward the group of ships.

The two pilots went on toward a row of cubicles which had been partitioned off at the rear of the excavation. Strange opened the door a little farther. The old metal room cut off part of his view, but he could see there were two lines of the flame-ships. Mechanics were removing a brass cylinder three feet long from an opening in the side of the nearest plane. They handled it gingerly, and he knew it must be a tank for the chemicals which created the green fire.

Another plane had been hauled back under a large shower. The engine and cockpit had been carefully covered. At a signal from an *Unteroffizier*, a man spun a valve. Grayish liquid poured from the shower, drenching the ship.

STRANGE nodded to himself. They were renewing the fireproof coating. A few yards away he saw a round tank, about eight feet high, with a glass panel in one side and steps leading up to the uncovered top. Through the glass that same grayish solution was visible. Obviously, this was the means by which the pilots fireproofed their skeleton suits, descending into the tank after turning on the oxygen in their helmets.

Across on the left side of the underground drome were other partitioned rooms, apparently quarters for the enlisted men. Nearer the rear he could see a Diesel power-unit which furnished electricity for the motors and ventila-

tor fans. The excitement which had followed the alarm had now died down. The mechanics were at work inspecting the flame-ships, removing the discharged tanks, opening the containers which sealed the Spandau belts from fire.

Strange's eyes hardened as they passed over the details of the hidden base. Von Wolfe had overlooked nothing. The place must have been weeks, perhaps months, in the making. He would kill ruthlessly to keep the secret from leaking out. Strange fought back the despair which started to sweep over him. There must be some way out—another exit beside that ponderous span which was camouflaged by the dummy chateau built on it.

His gaze fastened suddenly on a figure in brown. One of the pilots had taken off his skeleton suit, revealing a khaki uniform with U.S. Air Service insignia and wings. He joined another Boche attired in the same manner. The second man wore captain's bars. The two men went toward the officers' quarters. Strange saw that the mechanics paid no attention to them. Evidently, all of von Wolfe's pilots wore American uniforms so that they could discard the skeleton suits and masquerade as Yankees if they were forced down in France.

Strange looked down at his own uniform. It was rumpled and spattered with mud. He scratched off the caked dirt, smoothed his blouse. Watching his chance, he opened the door when no one was looking.

The blood pounded through his veins as he started across the base. It was a gamble, with odds stacked against him. He would win or lose in the next two minutes . . . .

A grimy sergeant stepped from in back of the fireproofing tank. Strange stalked on, fighting the urge to look back. He could feel the man's eyes on him, but there was no shout of alarm. Apparently, the Boche had taken him for a new pilot.

He was nearing the Diesel unit. An engineer stood with his back turned, reading his instrument dials. Strange passed. In a moment, his heart gave a leap. To the left of the officers' cubicles was a flight of steps leading up to a balanced trap-door. Here was the emergency exit. It probably opened into the woods. There would, undoubtedly, be a sentry or two on guard, but with the Luger and a little quick action, he ought to knock them out before they could give the warning.

He stole a look over his shoulder. To his dismay, the sergeant was still watching him. As he glanced back, the Boche turned quickly to another mechanic. The second man looked at Strange, then shook his head. Strange wheeled and swiftly climbed the steps. Only seconds now . . . .

A shout rose above the rumble of the Diesel. Strange seized the lever which operated the trap. Before he could haul it down, the trap swung upward. A startled voice rasped a German oath. Strange froze.

The man above him was von Wolfe!

## CHAPTER V

"WHERE'S THE PRISONER?"

FOR a second, von Wolfe and the men back of him gaped in amazement. Strange flicked the Luger upward. Von Wolfe lashed out a booted foot. The Luger blasted, and a Boche behind the *Rittmeister* toppled to the ground.

Von Wolfe's kick had knocked the gun from Strange's fingers just as he fired. It sailed back to the floor of the base. He whirled to leap after it. The German's heavy boot caught him as he spun. Headlong, he fell down the steps.

"Seize him!" roared von Wolfe.

Men sprang down the steps. A fist thudded into Strange's side. Some one kicked him furiously. Half-dazed, he was dragged to his feet. Von Wolfe waved his hand toward one of the larger cubicles.

"Take him to my room!"

Two enlisted men roughly marched Strange into the ace's quarters. Von Wolfe drew a gun, motioned the men to leave.

"Tell Captain Heimer to come here," he snapped as they hurried out. Then he looked back at Strange. An expression of unholy happiness came into his eyes. "So, *Herr* Brain-Devil, you have a fondness for meeting me underground?"

Strange did not answer.

"Since you like it so much, I will try to find a permanent spot underground for you."

Strange looked at the black hole of the Luger. "Well, what are you waiting for?" he said coldly.

"A matter of information." Von Wolfe looked past him as a man in field-gray entered. "Heimer, does the reward for this *Schwein* still stand?"

Heimer was a bald, pompous man. He pursed his lips, eyed Strange speculatively. "I'm sorry, but I don't seem to know him," he said.

"*Dumkopf!*" snapped the Bavarian. "This is the American air-spy, Captain Strange!"

Heimer changed color. "B-but that's impossible! Baron von Zastrov had him killed three months ago!"

"You and your stupid *Nachrichtendienst!*" fumed von Wolfe. "I tell you it is the Brain-Devil! Von Zastrov must have cooked up the story to appease the High Command."

The German agent stared at Strange. "Gott, if that is so," he said softly, "then the baron might be persuaded to pay a great deal more than the reward to keep this quiet. I happen to know that the Kaiser personally ordered the Brain-Devil to be removed. And von Zastrov reported that it had been done."

Von Wolfe's hard face took on a crafty look.

"Then we will keep this pig alive, much as I would like to kill him. The baron is a rich man. I think, Heimer, we shall bleed him for a little of that wealth. But not a word of this to the others!"

"I understand," whispered Heimer, a greedy light in his eyes. Then he

glanced at the clock on von Wolfe's table. "Two-thirty! Strasbourg will be clamoring for a report on your work tonight. And what of that *Spion* who escaped?"

The big German smiled mirthlessly. "I finished him with my own hands. Don't worry. They have no idea where our base is." He gave the agent a brief account of the destruction which had been accomplished, and what had happened after Strange had brought him down. "There must have been another entrance to that dugout, but there was only one plane on that field, so no one else could have followed us. Tell Strasbourg that the final tests were perfect."

Heimer went out. Von Wolfe summoned the red-faced *Leutnant* whom Strange had seen before.

"Have the prisoner securely tied and put in one of the storage rooms," he ordered curtly. "Keep a sentry on guard at the door."

The lieutenant took Strange outside, sent a man for ropes. One of the supply rooms was unlocked, and Strange was put inside, tightly bound. The *Leutnant* had switched on a light during the operation. He was about to leave when one of the men who had tied Strange pointed excitedly toward the cemented wall at the back of the room.

"Look, *mein Herr!* The thermite pipe is leaking!"

"*Gott im Himmel!*" exclaimed the officer. "Get wrenches and tighten it quickly. Tell the engineer officer to come here."

FROM where he lay on the floor, Strange could see the big pipe. It was covered with asbestos, and it was held up from the floor by thick brass tripods. Greenish crystals had formed a thin deposit at a bulge he guessed to be a joint. Faint green vapor trickled out now and then, turned into smoke.

Half a dozen men hurried into the room, following an officer in dungarees. They all gazed at Strange. The *Leutnant* swore.

"Never mind the Yankee!" he sputtered. "Get to work here."

The engineer officer beckoned to one of his men.

"Phone to the engineer on duty in the woods. Tell him to close the main supply valve and put a vacuum on the line to clear this pipe. We won't need to fill the rest of the plane tanks till morning, anyway."

The man scurried out. Several minutes passed before he returned. By that time, the vapor had ceased to trickle from the leaking joint.

"The pipe is clear, sir," the mechanic reported.

The engineer gave an order, and men with heavy gloves set to work on the joint. As the asbestos covering was pulled away, some of the greenish deposit was flicked into the air. One of the mechanics gave a cry and dropped his wrench.

"*Ach, Gott!*" he moaned. "It is burning my face!"

"Take him to First-Aid," the engineer officer rapped at another man. As the groaning Boche stumbled away,

he growled to the *Leutnant*, "Clumsy fool! He ought to know by this time what the stuff will do."

The joint was soon tightened and calked. The mechanics fastened new asbestos in place and left the room, eying Strange curiously as they went. The red-faced lieutenant bent over and tested Strange's bonds, then followed the others. Through the closed door, Strange could hear his muffled voice giving orders to the sentry.

Gradually the sounds of activity diminished, until only the rumble of the Diesel engine was audible. Strange struggled to loosen the ropes, gritting his teeth as the rough strands tore into his flesh. The Germans had left the fight on, and he could see the ropes which bound his legs and ankles. They had been tied by a master. His hands were tied behind his back, and every effort to loosen them sent little red-hot pains stabbing up his arms.

He relaxed after a few minutes, and looked around the room. There were several boxes piled up in a corner. Oil-drums filled most of the space. No sharp edges presented themselves. He rolled over onto his other side, faced the wall of the excavation. A hopeful look came into his eyes. The burned mechanic had left his wrench on the ground. There was a vague possibility that its metal jaws would be sharp enough.

It took him almost ten minutes to twist his way between two oil-drums and reach the spot. He worked himself up into a sitting position, turned his head to see the position of the wrench behind him.

He started. Some of the greenish deposit had fallen to the floor, close to the wrench. He wriggled backward, forced his bound wrists toward the spot. Half a minute passed. Something suddenly burned against his left wrist. A second later, he felt the strands begin to part. As the rope loosened, he jerked his hands in front of him and hastily wiped the spreading green crystals from his sleeve. There was a red patch on the back of his hand which pained fiercely. He wiped off the acidlike scum, then quickly untied the knots at his ankles.

Grim determination came into his eyes as he got to his feet. He picked up the wrench, tiptoed toward the door. He had not heard the padlock replaced. Evidently the Germans considered it unnecessary with him so tightly bound and the door guarded. If he could jerk it open and strike before the sentry yelled . . .

He turned abruptly and stared at the pipe behind him. For fully a minute he stood there, gazing into space. His chance of escape was hardly one in a hundred. There would be other men awake in the underground base. There still were the guards at the trap-door. Even if he could use the rope ladder and get up into the chateau, he would probably encounter another Boche. A hot search would be pressed as soon as his escape was discovered, and without a plane, it would be a miracle if he got back to warn Chaumont about this place.

But there was one way to be sure of its ruin. A way that would mean a horrible death for him if he did not escape . . .

LITTLE beads of perspiration dotted his brow. Then he thought of Lorton, of the men at the 53rd. Into his mind came a picture of the unfortunate G-2 men enveloped in flames.

His jaw tightened. He turned, swiftly began to unfasten the asbestos covering at the joint of the pipe. The engineer officer had ordered the chemical stream shut off until morning. The pipe obviously ran to a concealed tank in the woods, so that the main supply could not accidentally be loose at the base. That metal room outside—it must be a vacuum chamber in which the small plane tanks could be safely filled, for it was evident that mixture with the air at once turned the thermite into green fire.

The asbestos sleeve was loosened now. Strange worked it to one side, placed the wrench on the pipe. Setting it tightly, so that a scrape would not alarm the sentry, he backed it off till one side of the joint was clear. Ten minutes later, the joint had been removed from the other side. He hid it back of a drum, and was turning to replace the asbestos sleeve when there was a commotion out in the base.

He hastily shoved the asbestos over the gap in the piping. Taking the wrench, he crouched close to the door. Some one ran past the sentry, and Strange heard his guard fling a question after him.

The jangle of a bell echoed through the base. The strident voice of von Wolfe cut through the air.

"Emergency flight! Prepare to take off at once!"

Other commands added to the uproar. Strange could hear men dashing about the base. He turned cold as he thought of the break in the thermite pipe.

"Cut in the center blowers!" bawled a husky voice.

There was a scraping sound just outside the door where Strange crouched. Then he heard Heimer's anxious accents.

"But are you sure they do not know our exact location?"

"They have only the course, but that's bad enough," snarled von Wolfe.

"I still don't understand how—"

"This *verfluchter* Brain-Devil must have had a wireless in his plane," grated the Bavarian ace. "He followed us and sent back a message with the course. Then they ordered out this accursed Strafe-Wing."

Strange groaned silently. Jordan had remembered the course, had given the order after he failed to come back. Now von Wolfe's flame-ships would burn the American's out of the sky!

"Wait," exclaimed Heimer, from outside the door. "Are you sure you can trust this agent who sent the warning?"

"He is one of my former pilots," snapped von Wolfe. "If he says they will be here in thirty minutes, it will be thirty minutes. We've got to get



above those ships. Send word to the searchlight batteries to be ready to spot them for us. It won't be light enough yet."

THERE was a pause. Strange had a swift inkling of what was coming. He threw himself down where he had been bound, dragged the ropes about his ankles and thrust his hands under his back, still gripping the wrench. The door opened, and von Wolfe stepped inside. He carried a skeleton suit over his shoulder, holding the metal skull in one hand. As he came toward Strange, one of the skeleton pilots hurried in after him.

"Herr Rittmeister, there are tanks for only four planes—and the sergeant in the vacuum room says nothing comes through the main line."

"What?" roared von Wolfe. He wheeled toward the entry. "That *Esel* of an engineer must have had them cut off the valve in the woods." He jerked around, pointed a huge finger at Strange. "Bring that Yankee pig down to the vacuum room. I have something to tell him before I take off."

"Ja, mein Herr—" The bang of the door cut off the rest as von Wolfe strode on furiously.

The pilot put down his skull helmet and advanced toward Strange. The toe of his boot smacked against Strange's ribs.

"Get up, *Schwein!* If you think I am going to lift you—" He bent over.

Strange's leap upward and the swing of the wrench were all one lightning motion. The startled look on the German's face turned into horror as the wrench crashed into his head. His face turned the color of putty. Strange caught him as he fell. He had the Boche out of the skeleton suit in ten seconds. As he put the suit on, his eyes went with a morbid fascination to the asbestos sleeve which hid the break in the pipe.

There was a baffle plate in the front, which he saw was opened. He jammed the thing over his head, not stopping to fasten it to the suit. The sentry turned as he emerged.

"Come in here," Strange said gruffly through the opened baffle. "I can't lift this pig."

The man followed him. Strange stepped aside, clenched his fist. The sentry's mouth sagged open as he saw the dead Boche on the floor. Strange swung from the waist. The sentry reeled back against a pile of boxes, and slid to the floor, unconscious. The sooty marks of bony knuckles showed on his jaw. Strange flashed a look at the glove which formed an extension of his skeleton-suit sleeve. Hard-rubber strips, shaped like skeleton fingers, were fastened on both sides of the heavy gloves.

He scooped up the sentry's Mauser pistol and raced to the door. Shutting it hastily, he dashed toward the front of the base. Three planes had been started, and mechanics were working on the fourth. Several pilots were grouped around von Wolfe. All wore their skeleton suits, but they still held

their skull helmets in their hands. The Bavarian ace was rasping something at the thin, sallow pilot whom Strange had glimpsed earlier.

"This is your last chance!" Strange heard von Wolfe snarl as he came nearer. "I've showed you that there's no danger in diving through the stuff if you move fast enough. Bullets can't hurt you or your ship—unless they get your prop by a miracle," he added sourly. "Follow the attack scheme as usual when I signal. Is that clear?"

The thin pilot nodded apprehensively. Von Wolfe scowled, glanced back toward the metal room.

"Why don't they get those tanks filled?" he thundered at the engineer officer.

"They let down the pressure at the main station," growled the other man. "It's almost up to normal, and they'll start the stuff through."

Von Wolfe pivoted toward a non-com at the motor switches for the cantilever door. "Open up," he commanded. "We'll get those first three ships into the air."

Strange had just come past the corner of the vacuum room as the big ace wheeled. Von Wolfe strode toward him.

"Rorschach?" he demanded. "Where's the prisoner?"

"The sentry is bringing him," Strange mumbled through the skull helmet. "I thought I might be late—"

"Main lights going off!" shouted the non-com at the switchboard.

Strange shot a hasty glance toward the line of planes, to be sure of their position. Von Wolfe started past him as the bright lights dimmed. Suddenly a baldheaded figure came running toward the planes.

"Von Wolfe!" Heimer shrieked frenziedly. "The prisoner has escaped!"

THE Bavarian spun about with a furious snarl. Strange leaped sideways for the protection of the metal wall, for the instant forgetting his bullet-proof suit. Von Wolfe's howl came faintly above the grind of the huge door's gears.

"Stop him! The one with the helmet!"

The startled pilots ran toward the metal room. Strange ducked around the corner, dashed for the first plane in line. One of the Germans dropped his helmet and leaped.

Strange fired at his head, and the Boche sprawled forward onto his face. "The ramp! Block him off!" belated von Wolfe.

Men sped for the incline. Strange cast a desperate look toward the slope. The huge span had stopped half-lifted. There would be only inches to spare. . . .

With a roar, a stream of green fire shot from the room where Strange had been imprisoned. In a second, the blazing thermite was spouting emerald flame clear across the base.

Screams of stark terror burst from a score of throats. Strange saw the enlisted men's quarters blaze up in a green inferno. Running figures dropped like melted candles.

An awful heat surged out toward

the ramp. Strange clutched the side of the first flame-ship, hauled himself up to the pit. A terrified face showed, livid green, at the wing tip. It was the thin pilot who had betrayed his fear.

Strange opened the throttle, and the ship lurched up the incline. Green smoke gushed past him, clouding the ramp. He threw his hand over the opened baffle, crouched over the stick. The tip of the half-lifted span seemed to rush down on his ship. He held his breath. With hardly five inches to spare, the plane roared into the clearing.

Close at his tail thundered the second flame-ship. In the weird glow from within, Strange saw the face of von Wolfe. The ace had beaten the thin pilot to the ship. One more of the blackened flame-ships plunged from that green, blazing maw. As Strange pulled up in a climb, he saw a skeleton figure totter up the ramp. Back of the pilot, a staggering form showed for a second. Then a blast of emerald fire shot out and hid the man from view.

On blackened wings, von Wolfe zoomed up from the field. Strange had banked sharply away from the rising smoke. He saw the big German stare about him. Von Wolfe had fastened his skull helmet in place. Its hideous black showed against the glare beneath.

Strange reached for his gun trips, then remembered. Bullets would not bring von Wolfe down, and it was too much to hope for two miracles in one night, in trying for the prop. He sheered out farther, saw that the sky was beginning to turn gray. Von Wolfe plunged through the cloud of green smoke which rose from the flaming base. Strange turned to parallel his course. A moment later, he saw the other flame-ship which had escaped. The pilot was bare-headed—had evidently lost his helmet in his rush from the base.

Von Wolfe kicked in toward the plane, then gestured vigorously. Strange peered through the lenses of his helmet. The Bavarian ace was ordering the other man to follow him. The pilot was twisting away.

Abruptly, green tracers stabbed from von Wolfe's guns. As the emerald lines shot above his unprotected head, the Boche pilot hastily raised both hands. Von Wolfe jabbed his skeletonlike glove into the sky. The two ships zoomed steeply.

Strange swore. He had expected the loss of his base and men to crush von Wolfe. Instead, the man was going to make a last mad effort to win. A sick feeling came over Strange as he thought of the Strafe-Wing which would soon come roaring out of the gloom. One flame-ship alone might destroy most of the Yankee ships. Two of them . . .

STRANGE banked swiftly, and gazed westward. Ten miles away, searchlight beams were weaving across the heavens. Still more flared up as he watched. He could make out fitting specks, as the Allied pilots ruddered out of the lights.

Ten miles—not more than seven minutes! And those two flame-ships were climbing above the Wing!

Strange stood the black plane on its tail. Leveling out from that fierce zoom, he hurriedly scanned the sky. He glimpsed a darting shape ahead, as one of the Germans climbed against the shifting beams beyond. In a reckless climb, Strange followed. His hand ached from its tight grip on the stick. Would he never close the gap?

He was gaining! He could see one plane clearly now. It was starting to spiral upward, getting altitude for the deadly plunge. He wiped the smeared lenses of his helmet. As he moved his arm sidewise, his sleeve hooked something on his helmet. Oxygen began to flow from a compression-flask built in the back of the head-piece. He started to shut the valve, then locked his helmet in place and reached for the baffle-plate snap. It shut tight, muffling the roar of the engine.

A probing searchlight lanced up from below. It passed over the two Germans' ships before angling westward to hunt for the American planes. Strange's eyes narrowed. The man on the left was the pilot who had no helmet. Grimly, he let his hand slip down to the metal trips.

He waited. Precious seconds passed. Then another searchlight flashed skyward. Strange centered his sights, squeezed hard.

Green ribbons shot from the Spandaus, swerved from the back of the plane ahead. Strange twitched the stick. The pilot's head jerked under the blast. His ship nosed over and hurtled for the earth.

Von Wolfe had flung around in his pit as the first tracers appeared. Strange kicked to the right, praying for a lucky shot. Those lenses might not be proof against a direct hit.

The German nosed down swiftly. Strange plunged after him, engine belching. The massed searchlights were sweeping the sky, a mile away. He could see the Strafe-Wing now—D.H.

bombers and Spads. The Bavarian ace was pitching down toward them.

And suddenly Strange knew the only way he would ever stop von Wolfe. He shoved the stick farther forward. Like a meteor, the metal plane screamed on the tail of the Boche.

The searchlights were waving madly now. One swept across his wings, dipped toward von Wolfe's ship. He saw the ace fling a look backward. In the glow, the skull-lenses seemed to be eyes of fire. The tail of the German's plane was now within fifty feet of Strange's flashing prop. A grim smile came to Strange's lips. Von Wolfe dared not pull out. Their ships would crash headlong. And if he stayed in his dive. . . .

Without the slightest warning, a green inferno burst from von Wolfe's tail. In a flash, Strange was surrounded by a roaring mass of fire.

**F**EAR and panic struck at his heart in that first terrible moment. The cloud of green flame rushed over his cowl, billowed about his pit. Through the heavy suit he could feel the pressure of that searing heat. Surely it would eat through and into his body!

The scorching fire swelled to a roaring mass which enveloped his plane completely. Blinded by the glare, he clung to the stick. The ship seemed to be plunging straight down.

Abruptly, the dazzling blaze faded. Then through the diminishing green flame something came into sight. Strange gave a hoarse shout which rang in the metal helmet. It was the tail of von Wolfe's ship!

The German was pulling out, believing that sudden blast had driven Strange from his back. The tilted flippers were but five feet from Strange's flashing prop! Five feet . . . two feet . . .

Crash!

Strange jerked the throttle, cut off the racking motor as his metal prop burst into fragments. The fading green fire from von Wolfe's tank showed the

Boche ship for an instant. The tail had been sheered off as though by a giant scissors.

Von Wolfe whirled in his pit. Stark horror showed in the eyes behind the lenses. In that second, as the ship began to fall, the hideous black skull seemed alive with an awful fear.

Then the doomed man's ship pulled away, shrieked down the graying sky. Strange slowly lifted the battered nose of his plane to a normal glide. As he turned toward the ruined base, the white brilliance of a parachute flare shone out below. He saw the first D.H. squadron slanting down toward the clearing, where flame and smoke still rolled from the underground drome.

As his ship dropped under the swaying flare, the leading D.H. zoomed. A chunky figure in the rear pit whirled the twin-mount Lewises. Strange locked the stick with his knees, quickly raised both hands. The gunner kept his twin-guns trained as the pilot edged in warily.

Strange took one look at the bulldog face glaring over the Lewises. Hastily, he unfastened the skull helmet and lifted it from his head. Blank astonishment came into Colonel Jordan's face. Then he dropped the Lewis Spade-grip and gestured wildly. Strange grinned, and signaled for the D.H. pilot to follow him down. The two-seater droned after him, while the rest of the Strafe-Wing circled overhead.

Jordan was out of the D.H. before it had stopped rolling. Strange met him halfway between the ships.

"How in Hades—" the G-2 chief burst out.

"It's a long story," Strange said. "And we'd better get out of here—if you think two of us can squeeze into that rear pit."

As he took off the fireproof suit, he saw for the first time the bony ridges moulded into the iron boot-soles. Jordan's eyes met his. Strange grimly shook his head.

"Don't worry," he said, "the skeletons will never walk again."

## The Griffon's Gamble

(Continued from page 17)

"*Ko-Dachi!*" gasped Prance.

"*Ko-Dachi!*" agreed the Griffon. "You know what is inscribed on the handles?"

Prance nodded. His face was drawn, heavily lined, and his skin was like mouldy parchment.

"Well, what is it to be?" snapped the Griffon, staring at his wrist-watch. "The bullet of the Griffon, a firing squad at Leavenworth—or *Ko-Dachi?*"

"These are the knives from Yung Shi Pai's collection?" Prance asked hollowly.

The Griffon nodded.

Prance turned to the man in the scarlet mask. "Then if—" he started.

"The police might misunderstand," agreed the Griffon.

A low scream left Prance's mouth. He dropped the box, snatched out a knife and ripped the razor-sharp blade across his throat.

The Griffon moved like a flash. With gloved hands he picked up the bloody knife, wiped the handle quickly and removed Prance's fingerprints. Then, taking up the small card inscribed "The Griffon," he pierced it with the knife, stuck it upright into the top of the desk, and left silently by the window.

With the box taken from Prance's desk snugly stowed away inside his coat, he edged along the window-sill and found the metal pipe. He climbed to the flat roof and flashed his torch three times skyward. Then he darted into the shadow of a chimney.

**B**ELOW could be heard the honk of limousine horns and the low purr of marine engines down by the dock, but the Griffon had no ears for the normal sounds of the night. He was waiting for a tell-tale swish of a long steel cable. He knew the amphibian was still circling away silently above.

He huddled close into the shadows, his opera cloak drawn closely about him to cover the gleaming white of his shirt bosom. Gradually he caught the sound he was waiting for, a low whine.

The whine came more clearly to his ears. He darted out, snatched at something in the darkness and clicked his flash twice. There was a jerk, and something lifted the Griffon clear of the roof. His cloak spread wide, giving

the eerie impression of some monster bat.

A man who had been staring out of a window of the west wing, which reached above the main roof, saw this strange apparition, and gasped. But the Griffon was being drawn skyward by a long, steel cable that was being wound up by a small drum in the back cockpit of the tightly circling amphibian.\*

In three minutes, the Griffon was hauled in through an aperture cut into the bottom of the amphibian's fuselage.

"Grand work, Barney," he said. "Worked perfectly. Back to Graylands—fast."

The amphibian raced out to sea for a short distance, with the mufflers cut out.

"Wait!" the Griffon called. "Change over, Barney!"

They changed seats. The Griffon had flattened his opera hat and slipped on a rakish black-and-white plaid cap. He took over the controls and shot the ship over in a fast, climbing turn. Below, and heading out to sea, was a broad-winged Dornier "Wal" that carried normal American markings.

The Griffon nosed down and slammed over the two great B.W.M. engines that were housed in long, square-sided nacelles above the wing.

"What's the game?" inquired Barney.

"That's the Chink's ship. I wonder where it's going."

"Too far for us, I'll bet a buck."

"Make it two. We've been subsidized."

"You mean you nailed the dough?" asked Barney.

"Well, the deposit. Five hundred grand, as the boys say. Not a bad night," the Griffon laughed.

"Look out!" yelled Barney. "They've spotted us. They're firing!"

The amphibian nosed down and darted to one side. Her front Darn guns opened up, pounding heavy-caliber slugs into the great flying-boat. The sky was traced with a freakish design as tracers zipped across in the moonlight. From a deck hatch came two spumes of fire which zipped all around the darting amphibian. The Griffon flew like a hawk, his brain in supreme command of his controls. Now and again Barney was able to get in a few short bursts from his Colt-Brownings.

But this was not to last. From below came the sound of a Coast Guard anti-aircraft gun mounted on the forward deck of a cutter which was knifing its way through the water.

"No place for us," the Griffon

\*Author's Note:—This contact trick is no streak of imagination. A few weeks ago, the idea was tried out successfully in England by the R.A.F. A 2,000-foot length of steel cable was lowered, with a lead weight at the lower end. The ship 2,000 feet above circled at a speed of 150 m.p.h., and the weight at the end of the cable circled a spot eight feet in diameter slowly enough for men on the ground to attach a message form to it. There is no reason to believe this device could not be used to lift a man from the ground, as suggested in this story. All that is required is a short practice session.

grunted. "Those lads down there do not get this game. Let him go."

They whipped away while the Coast Guard men continued to bang at the speeding amphibian. Shell splinters whined and gun-cotton crashed out heavy detonations all around them. The Griffon headed north, climbed into the darkness and then shut off the motor by applying the Skoda lever which he had lifted during the fight to get the most out of the Avia.

"There's nothing like knowing when to pull out of a fight," the Griffon commented, as he headed back to his original destination. "We might have gotten into trouble up there, Barney."

"Trouble?" squawked the man in the back seat. "What the hell have we been in for months, since you got so restless?"

"Never worry, Barney. This is the life. Five hundred grand to play around with."

"Ought to be enough."

"What! Quit now, when it's just getting interesting?"

The fast amphibian was nosed down for the water. The Griffon handled her beautifully, and she dropped on the rollers and eased down on the step. The great Avia purred like a Cadillac as he edged her into her secret hangar.

Barney leaped out, fumbled for the levers that made the wings fold back and then pressed the button that opened the hidden hangar door. The rock garden seemed to rise slightly, and then two sections spread outward, leaving a wide doorway. The Griffon handled the throttle again, and the strange craft rolled inside and the doors closed back. This was the hidden hangar at Graylands.

They climbed out, opened a door at the back of the hangar and edged through into a narrow passageway that led into the cellar. Barney snapped a light on and together they reached for bottles from the musty shelves.

The Griffon selected a pint of Bollinger '09 and snapped the cork. The bubbly liquid flowed into a long, hollow-stemmed glass. Barney tugged at a cork of his favorite O'Doul's Dew and poured himself a real hooker. Under the dangling light of the wine cellar, they clinked their glasses and drank.

"And now, Barney," smiled the Griffon, "upstairs, a quick brush-over and off again."

"Again?"

"Again. The Dusenburg in five minutes, then on to Hubert L. Prance's dinner party at Rockland Manor."

IT was about twenty-five miles from Graylands to Southampton. The Dusenburg made it in exactly nineteen minutes.

A long line of cars was still pulling up the curving drive of Rockland Manor when the long black Dusenburg eased through the massive gateway. The lights still gleamed as they had an hour before.

But inside, there was a new feeling of anxiety and excitement. The music had stopped, and the guests were standing about in small groups, talking

quietly, in hushed, anxious voices.

Some one opened the door of the Dusenburg and stared inside.

"Mr. Keen? Mr. Kerry Keen?" the voice inquired huskily.

"Right. You are the park porter?"

"No—No, sir. Your car is to be left handy, just over there, sir. Compliments of Mr. John Scott and Mr. Drury Lang, sir, and will you go at once to the library?"

"Pull over there, Barney, and wait for me. Something's up. Righto, my man, and where is the library?"

"Never mind, Jenkins," a voice crackled behind them. "I'll show you up, Keen. Been waiting for you, myself."

A man in evening clothes stepped out of the car and grinned at Drury Lang.

"Hello, Lang," he said. "What are you doing here—guarding the treasure?"

"That's what we came up for. Some Chink bozo has been waltzing about with half a million dollars' worth of family plate and sunbursts on. Lucky, too—in a way. You knew that Mr. Prance was murdered, of course?"

"Murdered? Mr. Prance? With all you flatfeet around?" Keen answered. "How did that happen?"

"That's why we were waiting for you, Keen," Lang said. "We thought perhaps you could tell us."

"Damn it all, Lang," protested Keen, "can't I go anywhere without having you bob up with a murder mystery? How was he shot?"

"He wasn't shot—but it was the Griffon again."

"The Griffon?" Keen stopped in his tracks. "Oh, I say, Lang, this is too much. A little while ago you were half accusing me of being the Griffon. This ought to clear me."

"I'm not sure, even now, Keen, even though I saw you drive up. But come on up this way. They're all talking about bats up here."

"Bats?" asked Keen, as they went up past several chattering groups on the wide stairs.

"Bats—that's the latest. Byron, Mr. Prance's secretary, claims he saw something like a bat fly off the roof a few minutes before the body was found. Now they're all believing it."

Lang led the way across a wide hall and into the massive Rockland Manor library. Here Keen spotted John Scott, the Department of Justice man from New York, in conference with several men in tail coats. A few members of the servant staff were there, too. Another man was talking anxiously to the D. of C. man.

"But I tell you, Mr. Scott," he was explaining, "I was in my room in the west wing. The window on one side opens out on the roof of the Manor building proper. The light was fair, although the moon was partially clouded over. I saw this thing, just like a monster bat. It was black, and seemed to run across the roof, then spread its wings and dart into the sky."

"Did you hear any sound?" persisted Scott.

"No special sound. There was so

much motor noise down below. The guests' cars were beginning to arrive, you know. There was a boat down at the landing, too. But I'll swear I saw this thing fly off the roof. It was as big as a man."

Scott looked up and spotted Keen. He beamed.

"Glad to see you, Keen. Lang has told you?"

"About Mr. Prance? Yes. I was also listening to this gentleman's story. Have you searched the roof?"

"I have two men up there. But come along here. I want you to see this thing."

Keen followed Scott across the library to a massive black oaken door. Scott opened it and led the way in. Drury Lang followed them. And in the room, Mr. Hubert L. Prance lay back, a ghastly figure, with his shirt-front streaked in blood. In front of him, rammed into the top of the desk, was a strange knife. Scott pointed to it.

"The Griffon." He smiled wanly. "He's back again."

But Keen was staring down at the black ebony case which still lay on top of the desk on one side.

"That's funny," he said, almost to himself.

But Lang had caught the murmur. "What's funny, Keen?" he snapped.

"This case of knives. Where's the other?"

"What other?"

"Good Lord, man, can't you see? This case is made for three knives. One is stuck in the table, smeared with blood, and there's only one left in the case."

"Well?" Lang persisted. "What about it?"

"That's why we wanted to see you, Keen," Scott broke in to explain. "These knives are unusual, aren't they? Know anything about them?"

"All I know, Scott," explained Keen, "is that they are 18th Century ceremonial weapons of the Tokugawa era. A very unpleasant ceremonial affair, too. You have heard of *kara kiri*, of course. These weapons were originally designed for that purpose. They are family weapons, held by liege lords and used by their *samurai*, or soldiers, for use in case of disgrace or the expiation of a crime. You will notice that on the handle is carved the *samurai* phrase: 'A *bushi* has no second word.' In other words, a warrior never questions the dictates of his master."

**T**HERE was a respectful tap on the door. Scott said, "Come in."

A sergeant in uniform came into the room with something black and billowing thrown over his arm. "Here's your black bat, sir," he announced, throwing a parachute down on the floor. "We found it stuffed in a ventilator up there."

"A parachute?" gasped Scott. "But that man Byron said he saw the bat thing go up. You can't go up in a parachute."

Keen broke in again. "Beg your pardon, Scott, but isn't there a guest here—a Chinese gentleman who arrived in a large flying-boat?"

"I'll say there is," Lang said, jumping up. "This Yung Shi Pai chap whom we came to guard. He arrived with his own plane. He's a big-shot international banker of some sort. He's downstairs. Keen, you got the tie-up. Chinese knives, parachutes, airplanes and all that."

"No," corrected Keen. "Japanese knives, Drury, old boy."

"Oh! Well, no matter. These Chinks are all alike. They carve people up for an afternoon's entertainment. I bet that's the guy."

"Take him upstairs into the library, Lang," ordered Scott. "All right, sergeant," he went on when Lang had gone. "Leave this parachute here and see that everything is tight outside. Take over the guarding of the doors."

When the big bluecoat had left, Scott turned back to Keen. "What do you make out of this?" he asked quietly.

"That missing knife has me puzzled," Keen said. "The rest is easy. Some one slipped in here, probably through the window, and left the knives. Byron, the secretary, might know something about it."

"You mean you think he really saw a black bat?"

"Can't tell. There are other angles, you know."

"What?"

"Prance has been mixed up in several deals with Oriental syndicates. He may have pulled something, and they came to get him and—well, here you are. But I wonder where that third knife is."

Scott studied Keen for several minutes. "How do you know there was a third knife? And how do you know Prance was mixed up in anything like that?"

"I read the papers, Scott. And this Yung Shi Pai would not be here unless his financial tie-up was in the background somewhere. He's a big man abroad, and Americans don't go in for entertaining expensive Orientals unless there is something more than the social prestige to it—not the Prance brand, anyway. I'm afraid that other knife will turn up in a manner we won't like."

Lang came in and reported that Yung Shi Pai was outside in the library. They went out and faced a line-up composed of the big Oriental and his official party. Keen noticed that Byron stood in the background, his face drawn and white.

Yung Shi Pai was tall and broad, indicating a Mongol strain. He had a large, fierce face that even the delicate silks and embroideries of his official costume could not soften. His head was crowned with a small, flat turban from which plumed a black sable brush. His military tunic was of gold cloth and belted in with a broad leather band, fastened with a massive gold buckle. A ceremonial sword was stuffed into the belt in a fine leather scabbard that was etched and traced with silver filigree.

But the face, rather than the costume, interested Keen. It was cruel, with a hawklike nose, and eyes that seemed to flash fire and die out like a

hot coal placed under a bellows. The high cheek bones gave the face strength, and the unwrinkled skin that covered it seemed to be made of tanned leather. In the background, ranged in a formal semicircle, stood the Chinese's retinue of servants, bodyguards and minor officials.

**S**COTT tried to explain what had happened, but all his questions made no change in the Oriental's impassive countenance. Finally Keen came forward and shoved the ebony knife case containing the single weapon before the big Oriental.

"Does this belong to you?" he snapped.

Scott stared, amazed. The tall man cackled something to one of his attendants and received a note-pad and a stylus pen. He thought for a moment, then scrawled out a series of Chinese characters and handed the paper to Keen.

Keen looked up from it and asked for Byron. "You understand Chinese, don't you, Byron?" he asked. "Can you interpret this?"

Byron turned white. He looked at Yung Shi Pai, then stared at the message, and swayed slightly.

Finally he translated the message. "The Honorable Yung Shi Pai says, 'I consider this interrogation an insult. I demand diplomatic immunity from any such official investigation.'"

Scott and Lang looked puzzled. Yung Shi Pai remained impassive, and still. It was a critical moment. Keen slammed shut the lid of the box, and stowed it under his arm. He took the sheet from Byron's trembling fingers.

"That is what he said, word for word?" he demanded.

"Word for word," replied Byron.

"That's strange," answered Keen, smiling. "He has not spoken a word, and yet you translate his writing, word for word."

Byron went even whiter.

"Isn't it true," prodded Keen, "that the Chinese language cannot be literally translated into English? Isn't it true that Chinese grammar has no sense of inflections and concords, and that unless you hear the words actually spoken, you cannot interpret a written message exactly into English?"

"You are right, of course, Mr. Keen," Byron blundered. "I have interpreted it by bold metaphors. But that is what the Honorable Yung Shi Pai has stated here."

"This is the Pekinese form of Chinese, isn't it?" Keen went on.

Byron flamed up. "If you know so much about it, why don't you interpret it yourself?"

"Don't worry—I have," smiled Keen. "That's all, Mr. Byron."

Scott and Lang still stood perplexed, staring at the big Chinaman.

"There's nothing you can do, Scott," Keen told him. "You can't touch him, so you might as well let him go. We'll work on Byron. He's the key to it all."

As though he had understood every word, Yung Shi Pai bowed gracefully, clacked an order to his retinue. The

half moon of gilt and trappings opened up in the center. Yung Shi Pai turned on his heel and started to move off. Then he stopped, let out a low hiss and stared at the floor.

Between him and the door lay Byron, flat on his back, his throat cut from ear to ear with a long knife.

"*Ko-Dachi!*" snapped Keen.

"What?" Lang gasped.

"*Ko-Dachi!*" hissed Yung Shi Pai.

"The third knife," added Keen.

Scott was beside the prostrate figure in an instant, but it was too late.

"Allow the Honorable Yung Shi Pai to leave at once," Keen ordered. "Within half an hour, anyway."

"Half an hour?" Scott asked, fumbling with something in the man's hand. "Keep him here half an hour? Okay."

"What's that?" snapped Lang. "That thing you just took out of his hand?"

It was a small white card. On it was printed neatly, "The Griffon."

Lang snatched at it, and turned to Keen.

"Where are you going Keen, within the next half-hour?"

"Back to my New York apartment. I want to look up something," Keen replied.

"Oh, yeah? Well, you'd better look up something that will explain this. You were the last man to—well, you handed that message sheet back to this poor devil. I still think you're the Griffon!"

At these words, Yung Shi Pai let out a gasp that distracted both Lang's and Scott's attention. The big Chinaman was glaring at Keen with eyes that shot bolts of hatred.

Scott tried to laugh, but his effort seemed feeble. He looked down at the knife that lay on the floor near the man's open hand. "Go ahead, Keen, but look me up in the morning," he said. "You, Lang, detain Yung Shi Pai for half an hour."

"I'll stay," Lang growled, "but I'll be at your place first thing in the morning, Keen. You'd better have something good."

"Buzz in about, let's say, eight o'clock. I'll have something for you. I'll say good-bye to the Honorable Yung Shi Pai, too. You had all better do that. He won't be back."

Kerry Keen beamed on all present. Scott stood still, not knowing just what to make of it. Yung Shi Pai seemed rooted to one spot since Lang had said, "I still think you're the Griffon." His half-circle of moon-faced Orientals fingered nervously with their belts, sashes and trappings.

"If you speak their language, Keen," Scott ordered, "Tell this man that he will be detained for half an hour. You may go."

"Don't worry," Kerry said. "He knows every word you've said. He's been talking English for years."

As he slipped out, he whispered into Scott's ear, "Remember, keep him here at least half an hour. I'll get something for you."

Kerry hurried across the massive hall through the colorful knots of people and headed for the main entrance. A

few tried to stop him with eager questions, but Kerry had no time for them. Going past the officer on the door, he sent out a low whistle to Barney.

Keen climbed into the rear seat of the Dusenberg and in a loud voice ordered, "To New York, Barney."

The Irishman let the clutch in, and the car moved down the crunching driveway. At the gate, Keen suddenly countermanded his former order. "Back to Graylands, Barney," he said crisply. "And step on it!"

THE big black car swung to the right and they raced back to Keen's Long Island home. In twenty minutes, they were back in the house. Barney shot for the cellar at once. Keen went upstairs and tore into neat Byrd cloth flying kit. After selecting special weapons from a wide choice set in a secret drawer of his highboy, he darted down the wide stairs to his hallway, through to the hidden door into his underground hangar.

Barney was there, screwing back the caps of the tanks. Keen swung the ship around on the turntable and climbed in. His clock showed that it had been exactly half an hour since they left Rockland Manor.

Keen touched the starter that opened the Avia motor. He let her run for a minute or so, and then cut in the Skodas. Barney snapped the switch that started the door-raising mechanism and Keen ran the ship out into the open. The rest was fast work.

The Avia, silenced by the Skodas, took the black ship off like a winged ghost. Keen headed her back toward Southampton, climbing like mad.

"Well, what happened?" asked Barney, speaking for the first time since they had left Rockland Manor.

"Everything," snapped Keen. "They put one over on me. They got the leases."

"Damn my eyes!" snorted Barney. "You're slipping."

"We'll get them," Keen assured. "Byron, Prance's secretary, is dead. Throat cut—just before I left."

"Lovely!" Barney commented. "That will take some explaining."

"Oh, it was the Griffon again. Nice chap, that Griffon."

"What next?"

"Next? Oh, those four charities we were considering, Barney."

"Charity, eh? You'll be winding up with a tin cup yerself, one o' these days," growled the Irishman in the back seat.

"Have you forgotten the little black box already, Barney?" chided Keen.

"Hello, here's our gang!"

"Yeah, and they'll get away. Look out there," O'Dare retorted.

The great, swordlike beams off Montauk Light were cutting into a bank of mist sweeping in from the Atlantic. Below them, a great Dornier was heading out to sea from the landing below Rockland Manor. Aboard were Yung Shi Pai and the all-important leases that were to betray America in the Pacific.

"Break out that infra-red light beam," Keen snapped.

Barney drew out a strange instru-

ment that looked something like an old-fashioned magic lantern. The long lens tube was inserted in an aperture set in one side of the front cockpit, and the whole thing was fastened to a small shelf and held secure by butterfly bolts. He jammed the connecting cable down into a jack socket of a conduit that ran from their storage battery. Keen watched, keeping after the Dornier, and then snapped the switch. Out of the open aperture slashed a pinkish light that seemed to pierce everything. He nodded, satisfied, and shut it off again.

But the Dornier was already heading into the mist, and the black amphibian went down after it. A few desultory shots came up from the rear turret, but Keen danced the amphibian through them and nosed down.

"What are you waiting for?" O'Dare roared.

"I don't know. I'm in a quandary," Keen admitted.

"Ye'll be in a shroud if ye don't do something quick."

Keen was in a quandary, now. The fog had upset his plans. If he shot the Dornier down, there would be no assurance that he could get the leases and be certain they had not been passed through another group of Yung Shi Pai's mob.

However, he tore down and raked them with the heavy Darn guns. The gunners aboard the Dornier returned the fire, and Keen had to dart about fast to keep clear. He had to keep his pontoons water-tight.

Then they slammed into the fog. Keen snapped on the infra-red lamp and poked the long, polelike beam through the yellow mist. Odd twists gave strange, solid-looking walls weird openings through which at maddening intervals they could plainly see the Dornier. Keen tore in through those openings and fired long bursts at the silver-gray ship. Then the Dornier would disappear again until the finger-pink light fanged through the cloud and reflected strangely off the ship's dural sides.

Keen dived again and poured another burst from the Darns and Hotchkiss 13.2's. He went so close once that Barney let out a yell. The black plane zoomed up and streaks of tracer buried themselves in the muffing pall of gray mist.

It was insane to keep up such a dangerous game, but Keen had decided to gamble. He nosed down again and skipped in and out, trying to find the Dornier with his beam. The Avia was silenced again and he purred through the fog on silent wings. Once they almost slammed into a monster wing tip that seemed to be knifing its way through the fog.

They could hear intermittent roars from the Dornier's two big B.W.M.'s as they seeped back and forth through the fog. Then there would be a strange silence, broken only by the purring of the Skoda ports.

Back and forth, back and forth, the pinkish light stabbed. Now and then they would catch a gleam of the dural

boat, and Keen would charge down to hold it, but the gunners aboard the Dornier were blasting away at the strange light and Keen would have to dart away again and lose his trail.

For what seemed hours this went on, and all the time they were heading farther out to sea. But finally a break came. While slipping through the fog bank with his altimeter needle dangerously near the zero mark, Keen caught a new sound.

"Hear that?" he asked anxiously.

"Sure. A ship's horn of some sort," Barney answered.

"That's their game. They're boarding a vessel somewhere out here. Listen hard again. I'll throttle back some more."

The Skoda purr lowered, and the black amphibian dropped into a gentle glide. Barney listened out of his open window.

"Got it!" he came back. "A vessel below. The Dornier's down on the water near by. Must have ridden in on a radio direction beam. There it is—a big cruiser."

"We're going down, too. Get set, Barney."

Barney acted fast. He snatched at two kapok jackets and slipped one on. The other he held ready for Keen. They cut off the infra-red beam and dropped gently to the water. Leaving the Avia ticking over, Keen slipped out of his Dorsal harness and pulled on the jacket. Then with a few words to Barney, he crept out on the wing, listened carefully for a minute and let himself into the water.

"One hour, remember," he said quietly. "After that, beat it back to Graylands. You'll hear from me eventually—if it's from Hong Kong. Don't worry."

And with that, Kerry Keen struck out for the muffled sounds that came from an indistinct shadow about two hundred yards away. The Skodas purred; the black amphibian eased away, and Barney dropped a sea-anchor and settled himself for a long, uneasy wait.

KEEN could hear the activity on the other side of the two-funneled cruiser, where the Dornier was being eased up. He settled down to an easy, silent stroke and worked his way toward the sharp racing prow of the ship. When he reached the heavy anchor chains, he hung there while he peered around the side and watched the Dornier edge in closer.

Voices were raised in anxious orders and commands. A low light beamed out and showed men standing on the deck of the hull, steadying themselves with props, which had been stopped. Yung Shi Pai was standing on the co-pilot's seat in the control cabin, barking orders. Several men came out of the rear hatchway and climbed to the upper deck. Getting them off before they take the Dornier aboard somewhere aft, Keen thought to himself. Up the chain he clambered, and worked his way to the deck and huddled behind a winch. A folding gangway was being raised amidships and set for lowering to the

Dornier's deck. Keen crept into the clear and darted for the shadow of the bridge deck. The planking was sleek and newly varnished. A misstep threw him down, and he rolled over toward the scuppers. He had been seen, however, and voices were raised as men raced toward him.

Keen fought to get out his gun, but they were on him. Before he could make a move to get to the rail and leap overboard, they had pinioned his arms back and were rushing him along the deck toward the landing stage.

Yung Shi Pai stood under the low gleam of the portable light as Keen was brought forward. One of the men made a move to rip the scarlet mask from Keen's eyes, but Yung Shi Pai stopped him.

"It is well that this gentleman should remain just as he is—the notorious Griffon," the Chinese remarked. "It is an apt title. In my studies at Heidelberg, the Griffon was a figure in Teutonic fables, combining the outstanding features and physical attributes of the lion and the eagle. Truly a rare combination. And you, my unfortunate friend, combine the courage of the lion and the flying ability of the king of birds."

"Thank you for your courtesy," nodded Keen. "I appreciate your allowing me to retain my disguise. I'm sorry I gave your men such a fright. They are still trembling, even though I am carefully bound."

"Reasonable to understand, is it not?" Yung Shi Pai replied, stepping down to the deck. "They have heard much of you in the last few weeks and have every reason to respect you. You will come this way to the main salon. We must talk for a few minutes—before you depart."

The Oriental snapped a few orders in Chinese to the men who held Keen. They were tall Mongolians with bearded brows and fanglike teeth. They shoved him through the companionway and led him up to a large mahogany table. Then they withdrew to the background.

"My men have taken your weapons, I see. There is no reason why you should not be allowed some freedom. Release his arms!" Yung Shi Pai barked.

"Thanks." Keen smiled under his mask as they removed the cords. "That's much better. Now to business."

"Business?" The Chinese raised his eyebrows. "What do you mean?"

"You didn't suppose for one minute that I went swimming like this for pleasure!"

Yung Shi Pai frowned.

"I mean that I want the leases turned over to you by Hubert Prance!" snapped Keen. "The leases to the oil wells in Manchukuo which rightfully belong to the Columbia Pacific Syndicate!"

For a moment, Yung Shi Pai stiffened in his chair. "So that's what all your efforts have been toward?" he finally managed to say.

"Oh, come," Keen, retorted, "let's be frank. You are in a bad spot. Your

knives killed Hubert Prance and his secretary, Arthur Byron. It is only a matter of hours before you will be stopped by a United States destroyer and taken back. You can save yourself a lot of trouble by turning those leases over to the man known as the Griffon, who will see that they are returned to the vaults of the United States government."

"So you are the man who stole that case of knives from my apartment! Remarkably clever, that. But your offer is, of course, impossible. The leases now belong to the Manchukuo Petroleum Corporation."

"Rot! There is no such organization," Keen snapped. "We know that your moves are directed by an Oriental power, but you are not going to get those leases out of this country. It would be so much easier to turn them quietly over to me, and go on your little cruise. The deaths of Prance and Byron can be hushed up—as suicides—but those leases must go back to Washington. I really haven't time to wait any longer."

"Have you forgotten the indisputable law of *Ko-Dachi*?" demanded Yung Shi Pai. "It was you who unsheathed those blades!"

"Ah, yes," replied the man in the scarlet mask, quietly. "I had forgotten that. Prance knew it, and Byron knew it. You had tutored them well in your strange Oriental philosophy, son of the Great Khan."

Yung Shi Pai peered intently at Keen. "Then you know who I really am?" he asked.

"Of course. Once I learned that the mysterious descendant of the renowned Mongol was now working for Nippon, and was negotiating with Prance, I realized what was in the wind. Unfortunately, I was too late, this evening at Rockland Manor. Prance had already turned the leases over to you."

"Then there is no way out, Mr. Griffon," Yung Shi Pai growled. "Here is the third knife. You know the law."

Keen took the weapon which the tall Chinaman had placed on the table. Fingering the steel blade, he watched his captor draw a heavy Luger from a drawer.

"If that is your decision, I am sorry. Of course, I have no intention of ignoring your hospitality and the fact that I am a guest aboard a vessel flying a foreign flag. But please, a cigarette before I go. Ah, you have a splendid brand here. Your own, I believe. Will you join me?"

Yung Shi Pai reached for the carved cigarette box. He barked an order in Chinese to one of the guards in the background. Keen interpreted it to mean that the Dornier was to be placed back in the water, refueled and made ready for another flight.

The man saluted and went out. Keen took a cigarette, and watched the tall Chinaman take one. Then he fumbled in his breast pocket and came out with a small silver lighter.

"Here," he offered, "a light from a man who respects your Mongol traditions. This little flame may assist me

in my future gropings toward the land of our fathers."

"You are a brave man, my friend," Yung Shi Pai remarked with a patronizing smile. "I shall be sorry to see you go."

He placed the gold-tipped cigarette between his lips and leaned forward for a light. Keen raised the small silver lighter, clicked the igniter-lever. He shoved it closer to Yung Shi Pai's nose, but no light flamed.

"Ah!" began the Chinaman. "The novelties of the modern age do not work amid the—" Then he let out a low gasp, quivered from throat to knees and fell over backward. His head hit the floor behind with a leaden thud.

"**QUICK!**" Keen turned and snapped in crisp Chinese to the guards behind him.

"Your master has had a stroke. Get water, brandy—anything!"

He darted around the table and kneeled beside the prostrate Yung Shi Pai, stuffing the treacherous gas-discharge lighter back in his pocket. Then, while the four amazed guards looked for water, Keen fumbled through the tunic pockets, opened the throat of his neck-piece and released other tight clothing. He carried on a rapid jargon of explanation to the puzzled guards while he removed a large leather folder from beneath the man's embroidered vest. Slipping it inside his own shirt, he suddenly rose with the Luger, which had fallen to the floor.

The guards came out of their stupor. One leaped at Keen, but a short left hook put him flat on his back. Keen snatched at the man's long knife and backed toward the door. Something sounded behind him, and the guard who had gone out to issue the order about the flying-boat leaped at the back of Keen.

The man in the scarlet mask let him snatch at his shoulders, and then brought the knife up in a backward movement. The big Mongol guard let out a low moan. Keen jerked his shoulders and threw him clear over his head. Then, with a quick snap, he tossed the knife back into the salon. It clattered across the polished table, gory and dripping.

"There you are, my Mongol friend. Your *Ko-Dachi* law has been fulfilled. The unsheathed blade has tasted blood, as your dictates demand. Good-night. I'll see you where the lotus never perishes." And Kerry Keen disappeared into the darkness.

As he ran around the deck and plunged overboard, shots rang out, lights blazed and hoarse voices arose. But the waters and the fog covered his high-speed stroke perfectly. The deck searchlights tried to penetrate the mist, but the yellow pall stopped the glare.

For fifteen minutes, Keen plunged on through the muffled waters toward the spot where he had left Barney. He cupped his hands as he floated, and let out a cry. It was a signal that resembled something between the lilting strain of a whistling buoy and the harsh, discordant cry of a gull.

In response came the glare of the

# Advertiser's CONTACT

A LITTLE NEWSPAPER DEVOTED TO A BIG CAUSE ★ OF, BY AND FOR FLYING ACES CLUB!

VOLUME 13

AUGUST, 1935

WHOLE NUMBER 24

## ROBERT THOMPSON ARRANGES BEAUTIFUL WINDOW DISPLAYS

Wins Second Prop as Result of Increased Sales!

### A Bit of the Old West!

The page just inside the back cover of this issue carries an advertisement which proves of considerable interest to ACES UP for the reason that not so long ago he and a companion were flying in the West and had to make a forced landing in Idaho. Fortunately, we came down on a fairly level stretch near the Indian reservation at Fort Hall.

The only damage sustained to the plane was a bent propeller, but the country was so delightful and the Twentieth Century Indians so interesting, that we decided to tarry a while. True, we found the Indians using automobiles, but in accepting modern civilization, these original Americans have acted wisely in not throwing to the winds their "Indian civilization" in adopting that of the white man.

It was in this country, around a roaring camp fire, that we listened to many an interesting story concerning Ernest Thompson Seton, who lived with the Indians and whose name is known to practically every descendant of the copper-colored race. And so, it is interesting to note this advertisement dealing with Ernest Thompson Seton's *Library of Pioneering and Woodcraft*. ACES UP has become familiar with this valuable set of books and feels that all lovers of the great outdoors (and what FLYING ACES reader is not a lover of the world about him?) will be interested in this advertisement. We're sure you'll get a real kick out of these books—especially the volume entitled *Indiandraft*, wherein Mr. Seton has incorporated a careful scale plan for an Indian tepee.

At any rate, buzzards, the publishers—Nelson Doubleday, Inc.—are willing to send the complete set on approval, and you can take our word for it that the proposition is well worth your consideration.

### F. A. C. Units Going in for Air Instruction

Day by day more and more F.A.C. units are going in for actual air instruction, and just as today we can number among the 45,000 members of the F.A.C. some of the finest model builders in the world, we look forward, with confidence, to the time when we may number among our honorary members the names of leading personages in the field of aviation who got their start in the F.A.C.

Colonel Robert A. McGinnis, commanding the Buffalo, N. Y., division, advises he has acquired two instructors who instruct the boys, free, on engines, once each week. Also, he has secured the services of two pilots who take two boys a week and actually teach them to fly, the only cost being for the gas consumed.

Frederick C. James, commanding Flight C, New York City, tells us that interest has been greatly increased since Flight C acquired the able services of Captain Edison McVey. Captain McVey, a licensed pilot, owns a Hellanca plane, and has agreed to instruct members of Flight C in aviation and flying.

Hopping across the Canadian border, we pay our respects to our old friend Bert Macpherson, up in Hamilton, Ontario. Bert has a surprise for us, for his De Havilland Gypsy Moth is missing and in its place is a brand new DeHavilland Puss Moth. You can bet your boots that Major Macpherson's boys are getting actual flying instruction and, like Colonel Lindbergh, he has taught his wife to fly.

Turning towards faraway Australia, we find the F.A.C. unit at Sydney, under the command of Major H. M. Cameron, going in for aviation instruction in a big way. Among those giving lectures to the unit are Captain H. Ross, of the Royal Flying Corps, and Pilot Eric Kingsford-Smith, brother of the renowned Sir Charles. With information such as the above pouring in to us from all quarters of the globe, we are happy to realize that FLYING ACES is indeed serving a worthwhile purpose, and doing a good job in building interest in aviation and moulding airmen of tomorrow.

Bob Thompson, Toledo, Ohio, has found a way of winning his Second Prop, and his handiwork is pictured below. This beautiful and effective FLYING ACES display was set up in the window of C. L. Siegel's Drug Store, Nebraska and Miller Sts., Toledo, and represents only one of the many window displays put in by Bob on his patrol.

By examining the picture, you will note that the material used consists of several copies of FLYING ACES, a couple of models, four good aeronautic pictures, and a neat "shield" arrangement of the various awards

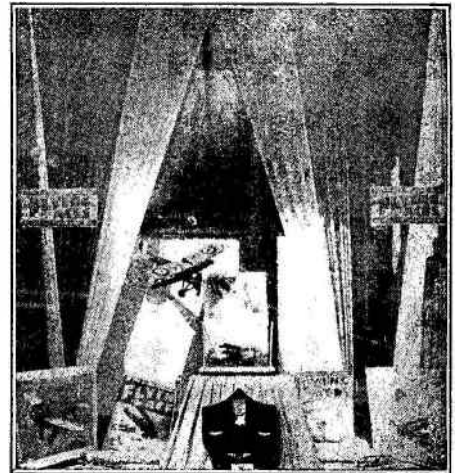

A Display that Resulted in Increased Sales!

of the Flying Aces Club. The arrangement is well-balanced, and we are told that it not only resulted in a sharp step-up in sales on the June issue, but also helped sell other merchandise by bringing new customers into the store.

Moreover, Bob has reported that, as a result of these displays, storekeepers have turned over to him the names of prospective members who made inquiries concerning the club. F.A.C.'s, ACES UP feels that this is a wonderful way whereby you can promote the cause of aviation by putting FLYING ACES over the top in the best way possible. At the same time, it is a peach of a way to secure new members. Almost any storekeeper will permit you, in arranging the display, to put a card in the window bearing your name, address and telephone number for the convenience of those who wish to join a Flight or Squadron.

Hop to it, buzzards, and put in some nice FLYING ACES displays, and be sure to send us some good, clear pictures. And during the course of your work, do not overlook the windows of the store where you purchase your model supplies. A good display will help that dealer also by bringing NEW customers into his store. And here's a promise: If you buzzards take this seriously and demonstrate to us that you are capable of putting in some good window displays, we'll consider offering a prize for the best FLYING ACES window display. Now hop to it readers—it's entirely up to you!

pinkish light, sent out by the infra-red beam. Keen caught it, heard the thunderous clangor of the B.W.M.'s back near the cruiser and slashed away again until he found the sleek pontoons of his own amphibian.

"Got them?" gasped Barney.

"Of course. What did you think I went for?"

"Well, we'd better be nudgin' off. Here they come."

While Keen crawled up into the cockpit, Barney started the Avia and slipped back to the rear seat. Keen cut out the Skodas and ripped the black ship up off the water. Ahead, the big Dornier slammed toward them. Keen knew that by now Yung Shi Pai had recovered from his sniff of gas and was in command again.

The guns of the Dornier ripped out and threw slugs all around them and, as if in response to the uproar, the wind shifted and the mist began to thin. Keen went to work. He slammed for height first, and tormented through a powerful barrage of anti-aircraft that came up from the decks of the luxurious cruiser.

Swerving around, he fought to get in position for a charging dive on the Dornier. Barney was already at it with the Colt-Brownings. The rear guns chattered and flamed, but the pilot of the Dornier was risking everything now and trying to stunt with the speedy amphibian. Keen took up the challenge and threw all caution to the winds. They exchanged broadsides at close range, but the speed of the amphibian and the indistinct lighting made it almost impossible to draw a clear bead.

Keen dived his black aerial charger full tilt at the Dornier and opened every gun. In return, the gunners aboard the flying-boat battered back and filled the sky with flame, tracer and lead. The concussion of the heavy-caliber guns was deafening. The black-winged ship staggered through the fire and fought for position again. Barney slammed away with his dual tubes, and watched the ship below stagger under the flailing.

"Get it into 'em!" roared Keen. "What are you trying to tickle 'em for? Pour it to 'em! They'll have us like a soup-strainer soon."

"Have a smack yerself," roared Barney. "I can't seem to touch 'em. They must be armored."

"The right idea," Keen agreed. "Try something else."

He nosed around, looked down at the big flying boat and made a quick decision. Going down with every gun flaming, he gave up trying for the cabin, but directed his full fire on the broad tail of the Dornier. He continued the roaring charge until it seemed as if the snub pontoon noses must fork into the control surfaces. Then he pulled out.

Below, the Dornier staggered, twisted like a speared cobra and threw away its tail. It fluttered off, swinging struts and a rudder that seemed to be hanging by one hinge-pin. Then, for a second, it seemed to fly on straight, but a cruel gust caught it and it swerved, nosed down and went headlong into the water

with a crash that sounded high above the roar of the Avia and the thunder of the cruiser's illegal guns.

"Home, James," Keen said, grinning. "I hope we have enough float left to drop on."

THE bell in Kerry Keen's 55th Street penthouse jangled on the dot of eight o'clock the next morning. Keen, in silk pajamas, bathrobe and slippers, answered.

Drury Lang wearing a dusty derby, thick-soled shoes and a scowl, wandered in. He glared at Keen, who appeared to have been aroused from a good night's sleep.

"Top o' the morning, Lang," greeted Kerry. "You look seedy. What—no sleep? You must have breakfast. O'Dare, the world's contribution to care and comfort, is just about to serve."

"Where the hell have you been all night?" demanded Lang.

"Oh, I went to bed fairly early. I cut off the phone and the bell, just to make sure I wasn't disturbed. Rather wearing, that mess out a Rockwell Manor, wasn't it?"

Lang continued to study Keen. "Go on," he said finally. "Let's have it."

"Have what?" demanded Kerry.

"That mess out there. What's it all about—that killing and cutting-up gag?"

"You mean old Prance and his man—what's-his-name?"

"What the hell do you think I'm here for?"

"Ah, yes, that knifing business. Nasty stuff, Lang. Those Chinese have funny customs. Been looking them up in that book over there, 'Chinese Tortures and Traditions.' Nice job, that book."

"I'm not going to bed until you do some explaining," Lang snapped.

"Explaining?" taunted Keen. "Oh, you must mean that black bat business."

"Yeah. You don't happen to do any flying yourself, do you, Keen?" Lang asked, casually. "I was wondering about that parachute, and the fact that Yung Shi Pai's flying-boat was shot down somewhere off Southampton soon after he left Prance's place last night. We got a line from the Coast Guard. They're all dead."

"Me fly?" Keen retorted, with a look of horror. "I can't walk over the Brooklyn Bridge without getting dizzy."

"No? Well, that's what happened to them, and it leaves us out on a limb. You'd better do some explaining yourself about the knife that finished off Prance and Byron."

Barney came in with a breakfast tray, nodded genially to Lang and set out two places.

"Go on," Lang ordered between gulps of food.

"Here's what I think happened," said Keen.

"What you know happened, you mean," Lang said.

"Let it go. Yung Shi Pai was really a descendant of the great Ghengis Khan. Up to last night, he was a secret member of a Japanese organization that is behind the Jap thrust in Manchukuo. Good he's out of the way, too."

"Go on. This is gettin' good."

"Yung Shi Pai was delegated by some one in Japan to recover certain oil leases from an American syndicate headed by Prance. Those leases covered fields in Manchukuo and distilleries at Fushun, Dairen and lesser plants in Manchuria."

"But," Lang protested, "those leases ought to belong to the U.S. government, in case we have trouble in the Pacific."

"Right! But Yung Shi Pai trapped Prance somehow—probably on some Oriental gag—and got him to turn them over to the so-called Manchukuo Petroleum Company for a sum of five million dollars. This was to be all hushed up, and once the transaction was completed, Prance was to pull out and skip to Europe."

"Who has the five million now?" snapped Lang.

"Only five hundred thousand was paid over so far. The rest was to be paid to Prance through some European bank. He got the five hundred thousand last night when he turned the leases over to Yung Shi Pai."

"What happened to it?"

"I'm afraid your friend, the Griffon, got it."

"Um! Then he did kill Prance?"

"Of course not. Prance committed suicide, probably because he realized the Griffon knew what he had done. He followed the tradition of *Ko-Dachi*. Yung Shi Pai must have sent him the knives, and the law is that if you uncover one of these knives, they must be fed with human blood. That was the tip-off for Prance. He knew he was licked—so he cut his own throat."

"Yeah? Very interesting. Is it all in that book?"

"Oh, yes, all of it," explained Kerry.

"You spill a good line, Keen. Now tell me how Byron got his. What did he have to do with it?"

"I'm not quite sure," Keen explained. "But he certainly acted queer about interpreting that message. I feel now that he was in on the lease steal in some way, and he realized that if Prance had been killed, there was a chance that he was going, too. Some one in that mob with Yung Shi Pai must have slipped him the knife, and he knew the answer."

"Then he committed suicide, too, eh?" growled Lang. "Ain't there a decent murder in the mob anywhere? But one thing more—how did the Griffon guy, whoever he is, get that card into Byron's hand?"

"You accused me of that last night," Keen retorted. "I've been wondering about it, too. Hasn't it occurred to you that John Scott might have put it there, for some reason?"

Lang's eyebrows went up, and he blinked. "Look here," he finally sputtered, "you got me all bawled up now. Lay off those parables or whatever they call 'em. Where does this leave me?"

"That's easy," Keen crossed to a cabinet. "Here are the leases Prance had signed over to Yung Shi Pai. They ought to be enough evidence for you. I'll give you those for a present, but don't ask too many questions."

"Where did you get them?" Lang



# Flying Aces Stamp Tales

**A MONTHLY FLIGHT VIA STAMPS  
PILOTED BY CHARLES CORWIN, A.P.S.**



**H**OW would you like to stage a plane parade? Well, the collector of air mail stamps can do just that. Your stamp album can represent the air routes of the world. Each page is a landing field, a factory, or your own private hangar. Flipping over the stamp book's pages, as flight commander, you may review familiar and outlandish types of "ships."

Here, take a peek through a magnifying glass at the airplane designs featured on air mail stamps! With the naked eye, you can identify many types of planes, but under a glass, a surprising number of technical details become visible.

Some stamps portray crude-looking crates that ought to be limited to the "ceiling" of a museum. Other issues present the most up-to-date streamlined jobs, delineated with photographic accuracy—both high-wing and low-wing monoplanes; biplanes with pusher- and puller-mounted power plants; ships equipped with retractable landing gear, wheels, skids and pontoons. In fact, practically every popular type of plane has at some time been honored with a miniature reproduction on a gaily colored postage stamp.

Let's look at just a few representative examples, and then you can have the fun of discovering for yourself further details on your own stamps. Although in the majority of cases, actual airplanes were used as models by the philatelic engravers, we must remember that some stamp artists, in designing these tiny bits of adhesive paper, have taken such liberties with the facts that Mr. Wright, *Monsieur Bleriot* and *Herr Fokker* would either not recognize their brain children, or would be insulted at the funny pictures that stood for their beautiful ships.

For instance, the Dominican Republic, which shares an island with Haiti in the West Indies, did not issue an air mail stamp until 1928, but it brought out a weird special delivery stamp which featured the native idea of what an airplane ought to look like. To us, it appears to resemble more closely a box kite or a glorified glider. The motor seems to be hitting on half-a-cylinder, while the carriage wheel

under gear requires an imperfect two-point landing.

Compare this flimsy contraption with the graceful, sleek, high-wing monoplane that zooms across a stamp from Indo-China. This central design on a French Colonial air mail spells speed in any language.

Circling back from Asia, this time to Europe, let us examine an Austrian semi-postal charity stamp. This is not an air mail issue, but it is of special interest since it was the first European stamp to depict an airplane. Italy, it is true, printed the first air mail stamp in 1917, during the war, but that stamp pictured nothing more exciting than the head of King Alfonso. The only aeronautical excuse for such a subject was the fact that in those days, the heads of all monarchs were spinning around like a radial motor on the test block!

*(Continued on page 79)*



**NEXT MONTH: ODDITIES & ERRORS ON AIR MAIL STAMPS**

— THEY ADVERTISE — LET'S PATRONIZE —

## Stamp Collectors!

Stamp dealers who advertise "approvals" will send to each person who answers their advertisement sheets with stamps on them.

Prices of these stamps are marked either under each stamp or at the head of the sheet. Stamps should not be removed from the sheet unless they are to be purchased. Remove only the stamps desired, mark in the proper place the amount you have bought and return the money and the sheets containing the remainder of the stamps to the dealer.

### 1897 NEWFOUNDLAND COMMEMORATIVE

Superb mint Cabot Commemorative (as illustrated), selling everywhere for at least 15c. Also Brunel, Turks and Caicos Islands, 55 U. S., and Imperator "Park." Everything only 5c to approval applicants. Extra! Extra! genuine Baden free with each order.



**VIKING STAMP COMPANY**  
Dept. F. A. 1 Hanson Place, Brooklyn, N. Y.

**HEJAZ, 3 DIFFERENT**  
(rare and distant country)! Multitude others! Free souvenir! Everything for only 10c to approval applicants. Illustrated Coin catalogue 10c. Big cash values!

**OWL STAMP & COIN COMPANY**  
175 Pinehurst Ave. Dept. F7 New York City

100 Different Airmails	.....	\$2.00
200 Different Airmails	.....	6.50
300 Different Austria	.....	1.00
40 Different Iraq	.....	.75
25 Different Palestine	.....	.40

Send for FREE Lists  
RIALTO STAMP CO., 109 1/2 W. 42nd St., N. Y.

### HEAP OF STAMPS GIVEN

From every corner of the world. Includes old U.S. Airmails, British Colonies, French Colonies, Belgian Colonies; also other countries as Panama, Fiume, Spanish Guinea, Liberia, Abyssinia, etc. A real grand lot. All for only 10c to approval applicants.

**NEW YORK STAMP & COIN EXCHANGE**  
246 Fifth Ave., Dept. S-6, New York

**DO YOU OWN A \$50 PENNY**

**INDIAN HEAD PENNIES**  
Up to \$50 ea. LINCOLNS and over 10 years old up to \$2 ea. Other Coins up to \$500. WHO KNOWS how much your old coins of yours will fetch? **BUY THEM!** To determine WORTH of your coins SEND 10c TODAY for valuable 1936 COIN CATALOG and for 120-Page illustrated RARE COIN BOOK.

**NEW YORK COIN EXCHANGE**  
246 Fifth Ave., Dept. F-8, New York City

**Your Dream Ship! Altitude! - Speed! Distance! Duration!**

The Gee Gee Special Designed by Carl Goldberg is The Last Word in Performance. Each Kit contains Complete Materials to Build Two Models and Includes Two Machine Cut Props, Extra Motors of 48's, Brown Rubber, 12 large Printed Balsa Sheets, Cement, Wire and Filings. Full Size Plans, Very Complete, Directions, etc. **Now Only 50c**

**MODEL RESEARCH LABORATORY**  
308 V. W. Randolph, Chicago, Ill. Plus 10c. Postage and Insurance

**WORLD WAR RELICS**

**FOR CLUB HOUSE OR DEN**

Vickers Aircraft Machine Guns—cost the Govt. about \$700 each—rendered unserviceable without marring; just released by War Dept. Weigh about 33 lbs. Send M. O., Check or Draft for \$75; P.O.B. N. Y. or on receipt of \$1.00 will ship C.O.D. by express.

**FIALA OUTFITS, Inc., 47 Warren St., New York**

**SEE OUR AD IN LAST MONTH'S FLYING ACES**

**LEWIS MODEL AIRCRAFT**  
2210 LOMBARD AVE., BERWYN, ILL.

**WATCH FOR OUR AD IN NEXT MONTH'S FLYING ACES**

**FREE To Model Dealers**

Out soon!—the new monthly publication devoted only to TRADE INFORMATION in the model field.

**The HOMECRAFTS DEALER**

Raw Material—sources of supply.—Sales Helps, new trade data, — everything that every dealer wants to know every month.

We'll send it FREE OF CHARGE to dealers requesting it on their business letter-heads. No dealer can afford to be without it.

We reserve the right to limit this complimentary list, so we urge bonafide dealers to sign their letters personally and mail them at once to:

**THE HOMECRAFTS DEALER**  
Room 1100-F  
330 West 42nd St., N. Y.

snapped. His temper was rising.

"There you go getting curious again! To be perfectly frank, I took them from Yung Shi Pai last night when he wasn't looking—and that's all you'll learn from me. Now get out of here. The case is closed, and I have a paper to read before the Department of Justice Ballistics Division. Pop off!"

"Oh-ho! So that's why old Yung Shi Pai took that other knife last night! He was after you." Lang beamed, satisfied that at last he had found out what it was all about.

"Did he take that other knife?" asked

Kerry blandly. "I'll bet he wished he had handed it to me."

"Now what the devil did he mean by that?" Drury Lang muttered to himself as he went through the door.

"**A**LL right, Barney," Keen said, about an hour later. "Here are five packages. Four are directed to our four pet charity accounts. See that they are properly deposited. The fifth you may deposit to the account of—well, let's see, who shall we be this week?"

"You mentioned something about a case of O'Doul's Dew," Barney remind-

ed him. His eyes were hopeful.

"Ah, a splendid idea! Deposit it to the account of Reginald O'Doul, Chase National . . . Thanks, a snorter before we go. See you at Graylands tonight. You'll have a bit of patching to do, eh? But stay out of the cellar."

"Chase National?" Barney mused. "Well, we did have a bit of a run-around while it lasted, eh?"

"But think of poor old Lang," Kerry said, adjusting his hat at a rakish angle and surveying himself in the long pier mirror. "He doesn't know yet just what happened. Well, three-pointers!"

## Suicide Spandaus

(Continued from page 19)

*"Oh, bury me not where the big shells bust;*

*Where my bones will rot in Flanders' dust.*

*But take me back where the shells don't scream;*

*Where the flowers are red, and the grass is green—"*

A hush fell over the room at Blab's doleful wail. Even after the song was finished, the silence lingered. Baldy put a smooth, rather fat hand on the captain's long arm.

"The hell of it is," he complained in that hushed voice, "that he means it." Baldy shifted his chewing gum nervously.

The captain shook the hand off. He had other things to worry about. He said shortly, "Let him sing it, if it'll do him any good. The trouble with the rest of us is that we haven't got the guts to sing. Not with the Germans slamming up that wall of ships against us every time we take to the air."

"Don't you savvy? It's a dying request," Baldy insisted, wrinkling the skin of his smooth cranium. "Suppose he gets dropped in Germany or in No-Man's-Land?"

"Suppose he does," the captain said petulantly.

"Who's going to pick him up and cart him home, eh?" Baldy asked grimly.

"Nobody," Stokes barked. "The dead have no claim upon the living. If it gives them pleasure to make requests, let 'em make them. We're not bound to carry them out."

Baldy's eyes opened wide. There was a hint of fear in them. "Maybe they have no claim," he agreed, "but just the same, Stokes, you can't ignore a man's dying request. It's bad luck."

"Rats!" Stokes exclaimed with finality.

**BLAB** BOOTH ambled across the room and stopped at the captain's table. He ground out his cigarette stub against the table top and faced the two men with a grin. Stokes liked Booth. Anybody that could grin under the present circumstances was worth liking.

Booth sat down and spread his bony hands out upon the table top. "Where's

the funeral?" he asked. "You guys look like mourners."

"Been discussing final requests of the dying," Baldy explained.

For an instant, the grin left Blab's thin lips. "Had any?" he asked laconically.

Baldy shrugged. "Not directly."

Stokes pounded the table with his fist. "The corpse we were discussing isn't dead yet. And if he were, would we be bound to risk our lives to carry out his dying desires?"

Blab rubbed his long neck thoughtfully. It was red, that neck, and coarse from much sunshine. "It's a serious question, gents. In life, a man can help himself. He doesn't have to depend upon his friends. After he's dead, he can't help himself. If his friends won't help him then . . ."

Baldy cut in. "I figure the same way. It's bad luck to turn down a dying man."

"Rats!" the captain snorted again. At the same instant, an orderly called Stokes to the door.

"Major wants to see you, sir," the orderly explained.

Without answering, Stokes legged over to the doghouse. Hot thoughts were boiling in his head. He pushed into the little office and stood stiffly before the battered desk without saluting.

The major lifted a grave face that boasted a graying mustache. Fingering the mustache, he walked to the map on the wall without a word. He picked up a stick, and pointed out a salient in the front lines extending from Nomedly almost to Verdun.

"See that bulge, Stokes?"

The captain nodded silently. The major went on. "G.H.Q. wants to flatten that out, and they're looking for us to help them."

"We need somebody to help us," Stokes retorted grimly.

The major glared. "G.H.Q. doesn't take excuses. You've been in the Army long enough to know that, Stokes."

"I've been in long enough to know strategy from suicide, sir," Stokes said hotly. "There are only three old men in my flight—myself and Booth and Baldy. The rest of them never live long enough to get any experience.

Maybe three of us have been a little afraid. Maybe we've been careful. Maybe we've used our heads—and maybe we've been lucky. We've lasted long enough to cut our second teeth. Maybe we've lasted too long—we're getting the jitters."

The major's thin mouth drew like a line below his clipped mustache. "I don't like to hear such talk from you, captain," he said stiffly.

Stokes was standing up straight, his big chest thrown out so far that the buttons on his blouse threatened to give way. "It's the truth, sir," he growled. "The new men haven't got any better sense than to run into a fight where they're outnumbered two to one. We older heads have seen it happen too many times. We've got a little respect for the Krauts."

"I don't care what you've got for them. You'd better have a few packages of death, for that salient has got to be cleared of planes. Go at it any way you want, but bust up that German blockade over Void!"

A silence followed the major's orders. Stokes' face was like a chiseled thing. Almost without moving his lips, he clipped out, "All right, sir."

**I**T was barely light enough to see the huddle of planes on the apron when Stokes legged to the line the next morning. Grimly he moved along the line of ships, giving them a last personal inspection. This was a precaution that had saved his own life many times, and which he hoped would do the same for the green replacements.

After the inspection, he called the pilots to him. "Men, we've been ordered to break that blockade over Void. It's a tough order. We're going to go at it in a different way than usual. We're not going directly to Void. We'll go to the Front near Nancy, and then head north to Nomedly. From there, we can go into Kraut territory and head west, parallel to the north flank of the salient, keeping not far from our side of the lines. That way, we'll strike the Germans from the back and drive the fighting into our own territory. It's a big advantage to know you're over home ground."

The men went to their ships. Blab Booth passed close to Stokes. "We'll bust that blockade like a keg of Pilsner," he grinned.

"Take the left cover, Booth," Stokes told him. Turning to Baldy, he said, "You take the right, Baldy."

Then Stokes legged into his own ship, and wriggled down in the pit of the Spad. That Spad had almost become a part of him. It was old and patched, and cracked and smeared with grease, but he had spent so much time in it that it had become part of him, like his arms, or legs. Grimly he adjusted his goggles and thumbed the throttle up the quadrant. The Hisso blasted its wild trumpet call against the shacks.

Stokes jerked a look up the line. They were ready—all of them were ready to do the war lords' business. He glared at the spine of bullets fed into the Vickers in front of him. It was bristling with steel-jacketed fingers of death. He throttled down and signaled the chocks out. The Spad leaped forward as he jabbed the throttle wide once more. Swifter—swifter! Tail up! Now stick back, steady! The wheels strummed from the clinging earth, whirling in the air as though loath to leave the ground. Then he was circling up.

Like a statue of ebony with face of ivory, Stokes sat behind the stick of the Spad. His flying coat was clean, his helmet closefitting and smooth. He was careful about everything, was Stokes. He growled deeply. You couldn't be careful enough about some things.

He passed Pont St. Vincent, where the railroad stopped at the side of the river. Then he was across and roaring over the ground from which all life had been drawn out by blasphemy. He could see the ruins of Nancy and the broken concrete walls of the Marne Canal. He circled north, following the gray strip of hell bounded by a trench that held dirty, grim men in khaki, and a trench that held dirty, grim men in field-gray. Then he struck the salient, crossed the lines and headed back west toward Void on the German side of the lines.

But A Flight of the 16th never reached the sky above Void. Over Domevre, a black cloud suddenly spawned eggs—eggs with wings and tracers licking out from the nose like wisps of lace. Stokes stiffened and flapped his ailerons. He broke formation. The new men scattered like grass before a wind. They were preparing to blast the flight of Fokkers, preparing to send the purple Boche ships squirming into hell.

Stokes cursed. He wasn't concerned with the first flight of Fokkers. His eyes were lifted. He could see the second V coming down to pick off the stragglers of A Flight. He held the stick grimly and timed his movements. He kicked the bar, legged the stick, and tore through the second flight of Jerry ships just as they struck.

Stokes could see his lead eating a line of holes in a purple belly. That belly seemed to split open. A dark object, with limbs flailing like the blades of a windmill, hurtled from that belly. Stokes

# BICYCLE GIVEN

## And Your Choice of 300 Other Big Prizes!

**OH, BOY!** Take a good long look at this latest model, deluxe Ranger Motorbike. Comes to you fully equipped as shown—with electric headlight, horn, curved platform carrier, coaster brake, rear wheel stand, and imported frame pump. One of the best of bikes. Built for speed and long wear.

And now imagine this: You can have this bike **WITHOUT COST**. Get your choice of 300 other prizes, besides. And earn **CASH PROFITS**. . . . Yes, sir! You can get these treats by delivering our 3 fine magazines in your neighborhood. It's easy! You can do it in spare time. Boys between 12 and 16, write today, and we'll start you. Besides getting all the money and prizes any boy could wish for, you'll be gaining valuable business training. Mail the coupon today!

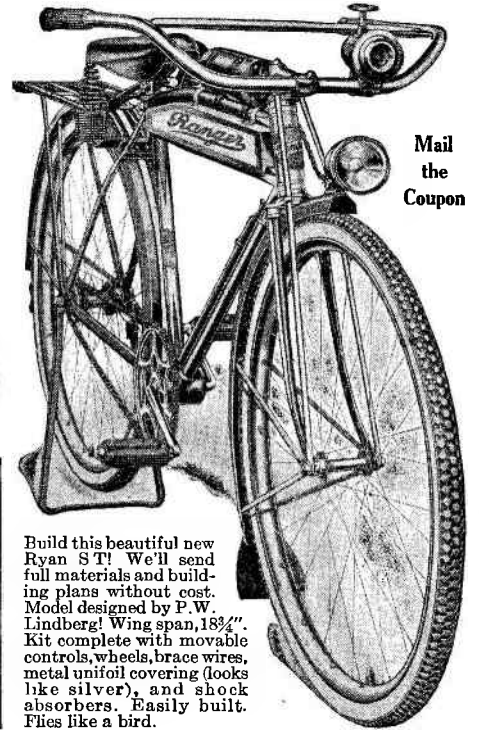

Mail the Coupon

Build this beautiful new Ryan ST! We'll send full materials and building plans without cost. Model designed by P.W. Lindberg! Wing span, 18 3/4". Kit complete with movable controls, wheels, brace wires, metal unifoil covering (looks like silver), and shock absorbers. Easily built. Flies like a bird.

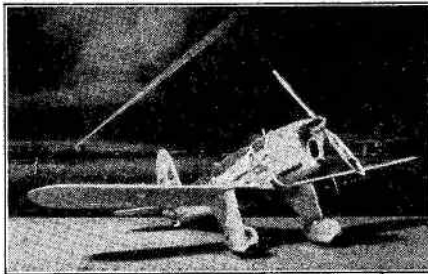

MAIL THE COUPON



### CAMPING SUPPLIES

When you go camping, you want a tent that is big enough to crawl into, and one that will keep you dry as toast. We've got it! We've got a pip of a canteen, cooking outfit, camp stove, sheath knife, and hand axe, too.

ALSO EARN CASH PROFITS

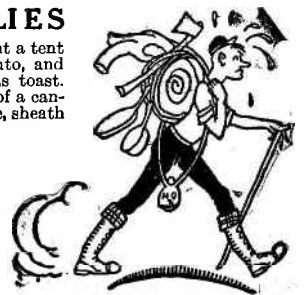

### BASEBALL EQUIPMENT

Like to play baseball? Then win one of our horsehide gloves (endorsed by "Babe" Ruth), a bat, ball, or shoes. You can get basketball, football, and golf equipment, too. In fact, almost anything in sporting goods! Mail the coupon NOW, and start winning our wonderful prizes. You can make heaps of money, too. Act without delay!



### FLASHLIGHTS

If you want a good flashlight—anything from a midget one-cell to a giant five-cell—we've got it. Or, you can get an electric lantern.

Win Prizes



Earn Money

## Mail This Coupon at Once!

Mr. Jim Thayer, Dept. 520  
The Crowell Publishing Co.  
Springfield, Ohio

Dear Jim: I want to win MONEY and PRIZES. Start me as a salesman at once, and send me your latest Prize Book, showing 300 items that can be mine.

Name..... Age.....

Address .....

City..... State.....

whipped back. He could see his rookies boring in to do battle, and his heart warmed at the sight. They had a chance this time. This time, the odds were even.

Like a catapulted thing, Stokes flung his Spad through that suddenly born hell. He saw another Fokker go down before Blab's snarling guns. He waved a hand at the grinning ace. Sudden death whipped past his head. He could hear the Spandau lead whine right by his very ear.

Stokes growled, and legged the stick. The Spad writhed like a form in agony. That was the way to slip from a Spandau trap. He straightened out and jerked a look back. A cold hand seemed to pat his shoulder. Bony fingers seemed to pluck at his sleeve, pulling shreds of leather from his coat. He was glaring right through the sheen of the screaming Mercedes into the bleared eyes of the stuttering Spandaus. Red eyes they were—red eyes that dripped tears of death!

**STOKES** hunched down. There was a veteran on his tail. All right, let the veteran follow this! You pulled your nose up. You flipped over on your back. Then you spun down! Top rudder! You triggered your lead swiftly at the thing that had been on your tail.

Stokes felt an empty feeling. The sky before his rings was empty and blue. His victim had anticipated that play, and was circling slowly waiting for Stokes to get in line. Stokes was in line. Again the Spandau lead hammered and slashed and tore.

Gulping back his curses, Stokes shoved the stick under the panel. There was one way that never failed. A Spad could outdive anything with wings. You set your tail pointing at the sun, and went down with a mad speed beyond will or mind to measure. The wind shoved you back against the pad like a huge hand. You could feel the air slap against your face like an ice pack. You could feel your goggles chafe at the bony sockets of your eyes—and you could feel the flesh press back against the skeleton of your face.

One thousand feet, with your ears popping and wires strumming. Two thousand feet, with your eyes blind and the blood stopped in your pulses. Three thousand feet, with the wings jumping on the hinges and the fabric peeling from the ribs!

Now was the time—now! Even a Spad had its limits. You pulled the stick back slowly. You felt a great force smash against you. You felt the pit sag and the spars bow like a willow branch. Your breath was sucked from your lips. Your blood was forced out against your skin. Your nose bled, and your eyes went blind, but if you rode that hell to its ending, you were free. Death no longer reached out for you.

As the force of the dive stopped, Stokes shot a bleary look back and stiffened. He wasn't free! The Fokker had been fooled before. The Jerry was wise and patient. He was coming down slowly, with Spandaus lined for Stoke's pit.

But Stokes saw something else. He

saw Blab on the Jerry's tail. Blab's guns were riveting death into the pit of the Fokker. The Jerry clawed at his face that was spouting blood. He flung his goggles from his blinded eyes. Then the Fokker turned over, and the Jerry spun down without wings.

Stokes breathed a mighty sigh. He tore past Blab on the way up to the fight. He saluted gravely. Today they were lucky. Three Fokkers down and no Spads. Incredible! He had planned the thing right. They would find the Germans in small bunches and get rid of them.

Once more he was screaming through the fight. He whipped his Spad about, and again he felt that great knot tie in his chest. Blab was caught in a trap! Two Fokkers had caught him in a cross-fire, and he was fighting to extricate himself! Stokes flung his Spad around, but instinctively he knew that he would be too late.

He could see Baldy, then. Baldy, too, had seen the trap. He was nearer. Like a madman, he was flinging his ship at the nearest of the Boche who were blasting Blab. But he could get only one. . . .

Stokes shoved the throttle hard against the stop. He beat his hand against the cowling, as though to force the Spad to greater speed. He held tight to the stick, his eyes glued to the rings, his thumbs heavy on the trips. He caught purple in his sights! Now!

Rat-tat-tat-tat! Rat-tat-tat-tat! His Vickers snarled and bucked. He could see his slugs hammering into the Mercedes. He sucked for air as fire flared from the engine. He glared at Blab, and his heart stopped. He had been too late. Blab was going into a spin. A thin pipe of smoke was licking back from the Hisso.

**BALDY** was half-standing in his pit, shouting. Stokes prayed silently that Blab would get control. Swiftly, crazily, the Spad was dropping. The pipe of smoke grew into a long steamer. Stokes and Baldy were following Blab down to protect his tail. A thousand feet down they went. Two thousand!

Blab's face was white, but he was grinning—grinning right into the toothless face of death! He was fighting with the plane. The Spad stopped its spinning. Stokes and Baldy, intent upon Blab's fight with the ship, failed to hear the dull throb of the dropping Mercedes. They had no warning of the Fokker until the purple ship was screaming low across Blab's cowling, feeding lead to the smoking engine.

Fire flared out, then. It licked back in greedy tongues from the pounding Hisso. Stokes stifled a sob that leaped to his throat. Still Blab didn't give up. He was sliding back out of the pit, astride the turtleback. He was tooling the crate with a hand reaching into the pit.

Sometimes even courage is useless. So it was with Blab. He held that Spad even within a hundred feet of the ground, slipping the fire away from the pit. Then the gas tank blasted suddenly, and the Spad broke up into a snarl of wreckage. Blab was hurled into the

air like something stuffed with straw. Stokes felt his heart stop. He closed his eyes against the sight of that falling body. Then he opened them.

He could see the burning Spad falling into some bushes on a lonely field. That other black spot beyond the row of trees. . . .

Baldy screamed close alongside Stokes. He was motioning that he was going down to pick up Blab's body. Stokes ordered him back, crying uselessly, "Stop—stop! You can't chance that!"

Baldy obeyed the motion of Stokes' arm. They screamed back up to the fight. But it was no longer a fight. It was suicide—murder! A gray flight of Albatrosses came out of the mists across the salient. They circled the swarming Yanks with a ring of steel death. Two Spads went down—three!

Stokes bit his lip. He ordered the flight back home. He tore a hole through the circling ships and led his tattered flight out of the salient and across the lines just west of Prouard. The Albatrosses chased them for a way, and stopped. Numbed and staring, Stokes led the battered flight home.

He set his own ship down so hard that a shock yoke gave way, whirling the Spad as the carriage strut dug into the earth. He sat for a minute, stunned and staring. Then he legged out of the pit, and stalked across the tarmac cross-ways, to the canteen. He couldn't chance a tiff with the major then. He had to have something under his belt besides blood and muscle.

Groping, almost, he flung the door back and strode up to the zinc-topped bar. He ordered a cognac, and before he could gulp the liquor, the rest of the flight stamped in. They were haggard and white. Baldy was the last of them. He moved up close to Stokes and downed two drinks from the sloppy bottle before he spoke. Then he faced Stokes squarely.

His fleshy face was almost haggard. He held his helmet in his fat hand. Sweat stood out in a film upon his bald head. "You did it, captain!" he said hotly. "It was your fault, our getting blasted. I wanted to pick that body up, but you made me leave it."

Stokes growled, the words sounding almost like a snarl in his lean throat. "Sure I made you leave it. What about it?"

Baldy's lips trembled as he licked the liquor from them. "Don't you see? We had good luck until Blab washed out. We were getting the best of that Boche covey in a hurry. But after we left Blab lying where he fell, our luck changed. We were practically shot out."

"Rats!" Stokes cried hotly, setting his glass down with such force that it was shattered by the blow. "You know what got the best of us? Those rookies were rattled by what happened to Blab. They forgot their fighting, and then those gray Albatrosses came over."

"Salve—that's what you're dishing out," Baldy interrupted him. "You're trying to salve your conscience. Blab didn't want to be left lying in a fighting zone. We'll be dogged by bad luck

**WHY THE GLOOM, TOM.**

AW, I CAN'T BUILD A MODEL FROM THIS KIT IT'S TOO HARD FOR ME

**WHY THAT'S NOTHING TO WORRY ABOUT, TOM.** YOU HEARD ABOUT HOW WONDERFUL HEATHE KITS ARE.

**WHY THEY'RE SIMPLIFIED KITS, AND UPGRADED.** SANDER BALSAS GOOD AIR MODEL BUILDERS DREAM - SEND YOUR ORDER IN THAT DOES RIGHT SOUND INTERESTING NOW

**FLYER**

TOM BUILDS A MODEL FROM ONE OF THE HEATHE SIMPLIFIED KITS - WITH GREAT SATISFACTION

**BOY!! WHAT A SWELL FLYER AND SO EASY TO BUILD TOO.** YES, SIR, I'M GONNA STICK TO "HEATHE" SUPPLIES FROM NOW ON.

**LISTEN Folks!**

TAKE ACE'S ADVICE DO WHAT I DID AND FIND NEW ENCOURAGEMENT IN BUILDING MODEL AIRPLANES, WITH HEATHE SIMPLIFIED KITST SUPER QUALITY SUPPLIES!

# This Offer Repeated by Popular Request

**FREE** We include free 6 sheets of 1/16" x 2" x 18" Balsa and 100 1/16" sq. x 18" on \$1.00 supply orders . . . free for \$2.00 order or more 200 ft of 1/8" guaranteed fresh para rubber. No postage required for free gift.

<b>DUMMY RADIAL ENGINES</b> (Celluloid, 9 cyl.) 1 1/2" dia. . . . . 20 2" dia. . . . . 25 3" dia. . . . . 35	<b>8" SHEET BALSAS</b> 1/64x2 . . . 4 for .10 1/32x2 . . . 5 for .10 1/16x2 . . . 6 for .10 3/32x2 . . . 5 for .10 1/8x2 . . . 4 for .10 3/16x2 . . . 3 for .10 1/4x2 . . . 3 for .12 1/2x2 . . . 2 for .15 (3" or 3"x18" double 2" width cost)	<b>JAPANESE TISSUE</b> White, per doz. . . . . 18 Colored, asst., per doz. all colors . . . . . 20	<b>ALUMINUM TUBING</b> 1/16 O.D. . . . . 08 per ft. 3/32 O.D. . . . . 07 per ft. 1/8 O.D. . . . . 07 per ft. 3/16 O.D. . . . . 10 per ft. 1/4 O.D. . . . . 12 per ft.	<b>BAMBOO</b> 1/16 sq. x 12 35 for .05 1/16 x 1/4 x 11 1 doz. for .07	<b>CELLULOID PANTS</b> 3/4" or 1" wheel 1 1/2" or 1 3/4" wheel pair .30
<b>18" BALSAS STRIPS</b> 1/32x1/16 35 for .05 1/16x1/16 35 for .05 1/16x1/8 20 for .05 1/16x3/16 15 for .05 1/16x1/4 12 for .05 3/32x3/32 18 for .05 1/8x1/8 16 for .05 1/8x3/16 12 for .05 1/8x1/4 8 for .05 1/8x3/8 6 for .05 3/16x3/16 8 for .05 3/16x1/4 5 for .05 3/16x3/8 4 for .05 1/4x1/4 5 for .05 1/4x3/8 3 for .05 1/4x1/2 3 for .05 3/8x3/8 3 for .05 1/2x1/2 2 for .05 1/2x1 1 for .05	<b>RUBBER</b> 1/32 sq 30 ft for .05 1/8 flat 17 ft for .05 3/16 flat 12 ft for .05	<b>COLORLESS CEMENT</b> 1 oz. . . . . 05 2 oz. . . . . 08 4 oz. . . . . 16 1 pt. . . . . 60 1 qt. . . . . 1.00	<b>CELLULOID WHEELS</b> 3/8" dia. pair . . . . . 05 1" dia. pair . . . . . 07 1 1/2" dia. pair . . . . . 10 1 3/4" dia. pair . . . . . 16	<b>SHEET CELLULOID</b> 6 x 8 for .07 MODEL PINS Per Pkg. . . . . 05	<b>GENUINE SUPERFINE</b> Per sheet . . . . . 07 Per doz. . . . . 75
<b>COLOR DOPE</b> White, yellow, orange, blue, red, green, olive drab, black, silver, gold 1 oz. . . . . 06 2 oz. . . . . 10 4 oz. . . . . 19 1 pt. . . . . 60 1 qt. . . . . 1.10	<b>HARD WOOD WHEELS</b> 1/2" dia. per pr. . . . . 02 1" dia. per pr. . . . . 04 1 1/2" dia. per pr. . . . . 06 1 3/4" dia. per pr. . . . . 11	<b>CLEAR DOPE OR BANANA OIL</b> 1 oz. . . . . 05 2 oz. . . . . 08 4 oz. . . . . 16 1 pt. . . . . 55 1 qt. . . . . 85 Thinner same price as clear dope	<b>WASHERS</b> 1/8" or 1/4" dia. . . . . 01 1 gr. . . . . 10	<b>BALSA BALLOON WHEELS</b> 1/2" dia. pair . . . . . 03 3/4" dia. pair . . . . . 04 1" dia. pair . . . . . 05 1 1/2" dia. pair . . . . . 07 1 3/4" dia. pair . . . . . 12	<b>ALUM. LEAF</b> .0003" thick 5 ft. . . . . 03
<b>WIRE STRAIGHT LENGTHS</b> Nos. 5, 6, 7, 8, 9, 10, 11, 12, 14, 15, or 16, 6 ft. for . . . . . 03	<b>STANDARD PITCH BALSAS PROPELLER BLOCKS</b> 3/4 x 1/2 x 5 9 for .05 2" x 3/4 x 7 for .05 2" x 3/4 x 6 7 for .05 3/4 x 1 x 7 3 for .05	<b>18" BALSAS PLANKS</b> 1" x 1 1/2" 1 for .07 1" x 1 1/2" 1 for .09 1" x 2" 1 for .11 1" x 3" 1 for .15 1" x 6" 1 for .25 1 1/2" x 1 1/2" 1 for .15 2" x 2" 1 for .20 2" x 3" 1 for .25 2" x 4" 1 for .35 2" x 6" 1 for .45 4" x 6" 1 for .75	<b>SHEET ALUMINUM</b> .002 thick sq. ft. . . . . 08 .005 sq. ft. . . . . 12 .010 thick sq. ft. . . . . 17	<b>MOTOR &amp; DRAG RING</b> 45 each <b>DOWELS</b> 1/16" dia. x 12" . . . . . 05 1/8" dia. x 18" . . . . . 10 doz. . . . . 10 3/16" dia. x 18" . . . . . 15 doz. . . . . 15	<b>REED</b> 1/32 or 1/16 6 ft. . . . . 02 3/32 or 1/8 5 ft. . . . . 02 <b>SAND PAPER</b> Per pkg. . . . . 05 <b>INSIGNIA SHEET</b> 12 pr. and rudder and tail markings with gummed back. Ea. . . . . 05 <b>15" Flying Scale</b> Model Plans Curtiss Robin . . . . . 05 Fokker D-VII Each

## BIG CONTEST STARTS! \$30.00 GIVEN

Many HEATHE model builders wrote asking why we haven't a slogan. Here's our answer!—Now you fellows get thinking and send in your suggestions on back of Heathe order blank or facsimile. Do not make it over 8 words. 1st prize \$15.00, 2nd prize \$10.00, 3rd prize \$5.00 and everyone who competes will receive a free gift with HEATHE'S compliments. Try your skill. New Contest closes September 30, 1935.



**See Our Big Prize Offer**

**Solid Replicas** Your choice of Boeing P-12P, Texaco Sky Chief, Spad, Fokker D-VII, Lockheed Vega or S.E.5, furnished with full-size plans and separate in-struction sheets and all accessories **3 for 25c**

**HOW TO ORDER . . .**

No orders under 50c. Add 15c for packing and postage to orders under \$1.50. Orders over \$1.50 add 10% of order. When ordering 36" lengths add extra 10c. Canada 10c extra. No. C.O.D.'s.  
New Big Catalog FREE with all orders or upon receipt of 5c.

here until we get him back."

"We'll be dogged by bad luck for a damned long time, then," Stokes predicted, and downed another brandy. Then he turned and legged over to the major's office.

The major greeted him coldly. "Your fight blew up, as usual, didn't they, Stokes?"

"Blab blew all the way to hell," Stokes said grimly.

"All right. It was his time, maybe. That's no reason why the rest of you have to run home like chickens. Be ready to go out again this afternoon. You've got enough men left for a patrol, and you can combine with B Flight."

A dark cloud of anger crossed Stokes' face. He fought back the words that leaped to his lips. "You're the boss, sir," was all he said, and turned on his heel, his long legs pumping mechanically as he passed through the door.

He went to the mess hall and joined in a silent breakfast. When it was over, he addressed them. "Well, buzzards, the day has only begun. We're going up again this afternoon. I know it's tough. It's none of my doing. All I can do is take orders. I just work here, like the rest of you. We'll combine with B Flight. Be on the line at three o'clock."

**I**N the afternoon, Stokes walked swiftly toward the line of ships before the cratershack. Baldy swung into step beside him. They were glaring at the ten ships throbbing on the line. They

were getting short of ships. They were getting short of men.

"We've got to be careful," Baldy said. "It takes luck to beat this game, and we haven't got luck with us."

"Can the chatter," Stokes growled. He was about to say more when an incredible thing happened. There was a mighty blast from one of the ships on the line. The gasoline tank exploded with a crimson convulsion. There was a wild scream as the mechs who had been working on the ship were hurled through the air. Fire swept out. A ship next to the wrecked one caught the flames. Men cursed. Orders were shouted hoarsely.

Stokes regained his senses, and leaped for the swarm of confused men. Some of the ground men were picking up a pilot and two mechs who had been killed by the blast. Stokes cried at the rest of the surging men: "Drag the planes out of the way. Pull them back from the flames."

He himself grasped a wing tip and swung a Spad around from the licking flames. There was sweat, and pain, and dust and smoke, and then the blaze died down. Cursing, the major struggled out of the crowd of men.

"No wonder we're a snap for the Boche," he cried. "We'll kill ourselves off if they give us enough time."

Stokes asked grimly, "Shall I take the rest of these men up?"

Baldy interrupted. "No, no. We can't go up there now. The rooks are all jittery. I'm jittery myself. We have a

curse on us. I told you how it would be."

"Shut up!" Stokes told him.

"I won't shut up!" Baldy screamed. Stokes hunched his body. His fist had hand swung up from his side. The weight of his slim body was in that blow. He could feel the bone crack as his fist landed on the button. Baldy dropped, like something stuffed and lifeless.

"Hold these men down," the major said swiftly, "I'll hop over to Epinal myself. I'll get some help. I'll get planes, and men. Be ready to go up within an hour." He ordered out an S.E.5 that had been sent up for experimental purposes. He climbed to the pit and warmed the Hisso briefly. Then he thumbed the throttle wide and cut down the field.

The blast of the engine brought Baldy to. He staggered up, staring at the major with glazed eyes. "He can't take off in that wagon. He'll turn a ground loop. The trucks are too far back."

Stokes paid no attention to him.

"He's lifting too soon!" Baldy cried. "He's pounding down! There he goes!"

The S.E. had bounded up, struck back and keeled over in a wild splatter of wreckage. The men ran toward the tangle of wire and rags and wood, in a body. Stokes and Baldy were there first.

Almost sobbing, Baldy said fiercely: "Bad luck—bad luck! I told you we'd have nothing but bad luck."

"Help pull him out of here," Stokes

# HEATHE Model Airplane Co.

438 East 98th Street      Drawer 208      Brooklyn, N. Y.

## AIR PILOTS WANTED

For a short period of time this organization offers a special membership to a limited number of young men and women.

The complete release of fledgling maneuvers with 76 illustrated subjects, Air Traffic Rules, Cranking Ship, Taxling, The Take-Off, Controls, Yaw, Roll and Pitch, The Approach, and The Landing of Airplanes—are the instruction brochures accompanying your special membership certificate.

### THE AMERICAN ESCADRILLE



"Composed of America's Present and Future Air Pilots"

The American Escadrille, an organization of American Air Pilots, Student Pilots and Cadets who are sound in mind and to the best of their knowledge and belief are in excellent physical condition and know of no defects in their health or capabilities which might render it hazardous to themselves or others while at the controls of an airplane in flight—

Who pledge themselves to abide by the Air Commerce Regulations and familiarize themselves with and obey the United States Department of Commerce Air Traffic Rules—

Who pledge to aid and assist Junior members of this organization, to do all in their power toward keeping aviation at its highest standard—to further its interests and make it safe as possible—

Time and membership are limited. Don't Delay. Fill out coupon and mail NOW.

AMERICAN ESCADRILLE, 2014 Broadway, N.Y.C.

AMERICAN ESCADRILLE, 2014 Broadway, N. Y. C. GENTLEMEN: Herewith is 35 Cents which entitles me to the special membership in the American Escadrille and the entire list of Cadet Maneuvers.

Name ..... Age .....

Street .....

City ..... State .....

## DEALERS!

Write for Samples and Prices on the FINEST MACHINE CUT PROPELLERS MADE. Or send \$1.50 for Trial Assortment of 84 props that retails for more than \$3.00.



Summer Special!—18-inch balsa gliders \$4.32 per gross—cash with order only. LAWRENCE AIRPLANE MODELS 507 Randolph-Franklin Bldg., Chicago, Ill.

## Two 12" Flying Models

Both approved by Junior Birdmen—one a biplane—the other, a monoplane. Scale models. Easy to build—sure to fly. Kits contain printed wood, full size drawings, colored tissue, all necessary balsa, ready-made unbreakable prop, correct insignia, etc. Unusual value. Supply limited. Rush 25c at once—we pay postage. Send today.

**PRESQUE ISLE MODEL AIRCRAFT CO.** 926 W. 6th, Dept. B-5, Erie, Pa.

## 1934 JUNIOR AERONAUTICS YEAR BOOK

By Frank Zaic—Second Printing

The last word in Model Aerodynamics and Designing. Acknowledged by Model Experts as the outstanding book in its field. Low priced because of special Printing Process. Only 35c a copy. Postpaid anywhere.

"JASCO," 328 East Sixth St., New York, N.Y.

You can make the AIRCRAFT CARRIER "SARATOGA"

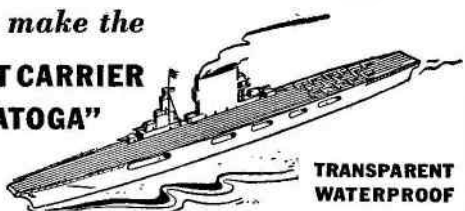

TRANSPARENT WATERPROOF

SEND FOR THESE FREE PLANS Use quick-drying Du Pont Duco Cement to make your model stronger. Send green carton or red disc from 25c tube for free plan. DU PONT, Dept. K-2, Wilmington, Delaware.



# DUCO Household CEMENT

— THEY ADVERTISE — LET'S PATRONIZE —

growled, fighting with the wreckage. Together they got the major free. He was limp and senseless. A red welt showed across his head. Blood streamed from a bad cut on the jaw.

They carried the wounded man to the recreation room and called the medico. Then Stokes legged grimly to the office. He took the receiver from the hook of the phone. There was no use in going to Epinal. If they wouldn't send planes, they wouldn't. What good could personal persuasion do?

"Hello—hello? Epinal? . . . This is Captain Stokes at Vezelesi. We need a flight of planes bad, up here. Can you help us out?"

The voice on the wire coughed for a minute. "I don't know, Stokes. Can't send you anybody from here, but might get you a flight from St. Die. If I can get them, I'll have them report to you as soon as possible."

"Thanks," Stokes said in a dead voice. He slammed the receiver to the hook and stared dully into space.

The help didn't show up that night. He ordered the men to bed early. At the first crack of dawn, he was out on the tarmac. The mechs were swarming over the ships. As he reached the line, he stiffened. Baldy was warming the engine on a Bristol Fighter.

"Where you going with that hack?" Stokes asked him grimly, moving close to the side of the forward pit of the two-seater.

"I'm following you," Baldy said glibly.

"I can tell you what you think you're going to do. You think you're going into Germany and bring Blab's body back. Well, get that notion out of your head. That two-seater won't last a minute in a bunch of fast Fokkers."

"I gotta bring him back," Baldy pleaded.

THE rest of the pilots had come up, and engines were roaring in the throes of warming up. Suddenly a shout went up. A dull thunder echoed down from the clouds.

"Zeppelin! Going home from a raid on Paris!" The cry was shouted from lip to lip. Men swarmed into planes. Stokes leaped into his own pit and thumbed the Hisso wide. He jumped the chocks and sent the Spad leaping into the air with one huge bite. Then he looked back.

The rest of the planes were following him up. He groaned. The Bristol was on the end of the line that was rising from the earth. Stokes shrugged. He told himself that luck and brains

went together, and that Baldy had neither.

Up—up—up! Prey birds rising to the kill! Eight thousand feet—ten! Clouds slipped past them, and still they climbed. Stokes planed at thirteen thousand and headed after the huge shadow of the Zep. He knew it would be no easy job. There would be a swarm of Fokkers there to protect the monster.

The Zep was hitting a straight line over Toul. It was heading for the lines at the nearest point. Stokes gunned the Hisso and sent the Spad screaming for the huge bag. He was over it. He was heading down.

At the same time, the Fokkers swarmed in. Stokes paid no heed to them. He had his guns lined for the Zep, and he sent a burst into the big bag. He waited for the blast of fire that must come, but it didn't come. Instead, he roared past with a futile feeling. The high-speed slugs had gone all the way through the bag without igniting the hydrogen.

Hell broke loose, then. The Spads strove mightily to get at the Zep. The Fokkers lashed and snarled to keep them away. Once, Stokes could see the Bristol, and he cursed. The Bristol wouldn't have a chance without a gunner to protect its tail.

He swung back. Again he sent lead crashing into the huge gray shape below him. Spandau lead smashed into his own pit. He pulled the Spad up and spun over a wing, roaring back in a neat reversement and feeding death to the Fokker that had attacked him. His slugs flung through the sheen of the Mercedes. They hammered into the mighty engine. They knifed the oil lines from the fittings, and broke the gas line at the filter.

The Fokker seemed to leap into fire all at once. Stokes stiffened. A sudden knowledge caused a great cry to surge from his lips. The burning Fokker was doing the job that he himself couldn't do. It was falling upon the Zep! It struck with a mighty surge of fire, and the very air seemed to suck and wheeze like a giant choking.

Stokes fought with the stick of the Spad. The Hisso droned wildly as the Spad was flung up. Then he got control and jerked a look across the sky. He could see the Bristol going down in a crazy spin, with Baldy clinging to the stick.

Then the Fokkers swarmed in for vengeance. Back and forth—up and down, over and over—snarling, lashing, bucking! So that fight surged. It was like the wild dance of strange ritual. A Spad went down flaming. The Fokkers struck with renewed energy. Stokes cursed. The Spads were losing altitude. They hadn't a chance—not a chance!

Suddenly he remembered Blab. He shook the thought from his mind savagely. He gripped the stick hard. He thumbed the trips in short deadly bursts that slit wings, punched holes in pits, that lashed into controls, and yet the Fokkers failed to fall.

At that instant, Spandau lead whistled past his ear. It struck against his crashpad like a hand calling for

attention. He squirmed and sent the Spad in a roll. Again the lead hammered at him. He could feel it lash into his controls. He tensed, pulled the stick back, and kicked the rudder. He was heading back, but the Fokker had turned, too. Spandau lead laced a neat row of holes through his pit. He could feel a burn across his leg, as though a hot iron had touched him.

Grimly he threw the stick forward and started down. He could always dive. There was always that chance. Down—down! Swifter. Once more, as he had done so often, he belled the stick, and the Spad slid across the air. The spars cracked and groaned. Stokes screamed with pent-up emotion as the fabric tore off in wide panels.

Once more the trick had failed him. His left wing was sagging, and through the struts of that left wing, he could see the Fokker lashing for him with blazing guns. This was the end, then. He could not lift the left wing for a bank. To turn meant to strike the Fokker. All right, he'd strike it!

He kicked the rudder cautiously—but that maneuver was never completed. At that instant, Stokes saw a ship riding up from the ground haze. It was the Bristol. He let the Spad go down to meet it. The Fokker followed. As he neared the Bristol, he stiffened. There was a man in the rear pit of the Bristol—a man draped grotesquely over the mounted Lewis guns.

The Fokker was still busy, lashing lead into the pounding Hiss of Stokes' Spad. Then that Fokker whirled away. The Spandaus became silent. Stokes laughed mirthlessly. The Boche was afraid of the rear guns of the Bristol. He was afraid of the man in the rear pit—and that man was a dead man. It was the body of Blab Booth!

Watching the Bristol, the Fokker forgot Stokes. Stokes slid the Spad around, and thumbed the Vickers. He couldn't miss. The Fokker whirled down like a falling leaf. Stokes waved at

Baldy. Together they rose up to that hell above the clouds.

Stokes had a curious feeling that Blab was bringing them luck. He had saved Stokes, hadn't he? But up here in the dogfight, things looked hopeless. Another Spad had fallen, and the Fokkers were swirling in to finish off the Bristol. Stokes lashed across with both guns spitting death.

At that instant, a mighty cry leaped from his lips. Through a cloud bank came a line of brown ships—familiar ships, with whirling motors dragging them to the rescue. The flight from St. Die had arrived. Luck was with the 16th!

With the help of the brown Nieuports, the fight was soon over. There was one vicious burst of insanity. The air spewed Fokkers. The ones lucky enough to escape the Vickers lead ran home gladly. Stokes could feel the sweat around the padding of his goggles. With a grim smile, he signaled the planes home.

**B**LAB'S body was laid out in state in the recreation hall. The men all went over to the canteen and lined up at the bar to drink him a farewell salute.

Baldy lifted his glass high. "I told you mugs it was bad luck to leave a buddy lying where he didn't want to lie."

Stokes gulped his drink and wiped his lips on his sleeve. "Rats!" he growled. "Luck is a matter of brains and guns and—"

Baldy ignored him. "There's a nice green spot over beyond Charmes where we can bury Blab. He wanted the grass to be green."

Stokes drew his slim hand from his trousers pocket. He slapped a wad of francs on the bar. "Buy him some roses with this—red roses!"

The men stared at Stokes curiously. Somebody in the back of the room began to wail:

"Oh, bury me not. . . ."

## Dog Flight

(Continued from page 13)

small oil stove and went to bed. Morning found him hanging something up on the branches of an old apple tree in the rear of B Flight's hangar. Sergeant Casey looked at it and scratched his head.

"Why, it's only thread," the flight non-com exclaimed. "Lootenant, if it ain't bein' too forward, could I ast ya—"

"Casey," Phineas said severely, "you can see it's black thread, can't ya? I wash it at times. I hate dirty thread."

Casey blinked, squinted closely at his superior, then turned and went about his business.

"Nuttier than a squirrel's commissary," he muttered. "They ought to put that guy away."

G.H.Q. and Wing Headquarters made life miserable for flying units up and

down the convulsed front line all that day. The Jerries were moving up truck and flatcar loads of shells to a salient which had been a sore thumb to the Allies for two years. In the shadow of Mont Sec, they had dug into a rocky hillside and had made a storehouse. All the Allied eggs in the world could not belt them loose. Squadrons had tried it, had come back wishing that the warriors of old had been more successful against the flaxen-haired Huns who had swept down from the north. The Krauts laughed gutturally and sipped *Schnapps* as they crouched in dugouts, watching the bombs chip away at solid rock.

Major Rufus Garrity was getting pretty sick of the arguments with Chaumont. It was like battling an octopus with all its tentacles. The buck was

**HEY FELLOWS-LOOK!**  
**A REAL FOLDING**  
**CAMERA FOR**  
**ONLY**  
**\$1.00**



**Univex**

**DE LUXE FOLDING**  
**CAMERA**

Yes siree! A real folding camera . . . for only a dollar! Light, compact, streamlined! Slips into any pocket. Ready for shooting in a jiffy. Takes knock-out pictures—either snap or time exposure. Hand polished, imported lens gets every detail. Special device for crystal clear snaps or time exposures. Enlarges beautifully.

**THE FIRST FOLDING CAMERA FOR \$1.00**

Don't wait! Get this keen little Univex now. Be the official photographer for your Flight or Squadron. Shoot pictures of hikes, camping trips, sports. Sell prints at a profit. Film only 10c for six shots.



**FILM only 10c SIX SHOTS**



Made in U.S.A.

**THE GREAT UNIVEX CONTEST!**  
**\$5,000.00**  
**IN CASH**

Contest just started! \$5,000.00 in cash and many other valuable awards will be made for good photos. Get rules with your order. Have fun, make money with Univex.

*Money Back If Not Pleased*

**How to Order Send No Money**

Send name and address. Pay postman \$1.00, plus postage. Films 10c extra each.

**Colors**  
 Choice of Blue, Gray, Brown, Green or Black.

J. H. WINN MFG. CO., Dept. 1608, 124 West 23rd St., New York.

Send Univex Camera and . . . . . films postpaid. Enclosed find \$ . . . . .  
 (Send above order C. O. D. I'll pay postman). Color . . . . .

Name . . . . .  
 Address . . . . .

Note: Canada 25c extra cash with order.

## NEW! Now TROPICAL Offers 12" WING SPAN

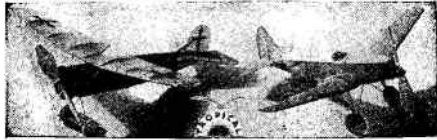

## FLYING MODELS

Another Tropical sensation—four great little FLYING models, at only a dime apiece. Picture shows (right) DF-3, Heath Low Wing 700, (left) DF-4, FOKKER D-8. Others now ready are DF-1, Monocoupe 110, and DF-2, Fairchild 22. Like our popular 3/16" solid line—each Kit comes complete with printed wood, cement, full size plans, propeller, insignia, etc. In ordering less than 4, include 5c per Kit to cover packing.

**10¢**  
EACH

### SOLID MODELS 10c

Spad 13, SE-5A, Boeing F4B 4, Fokker Triplane, Nieuport 17, Albatross, Heinkel F2B-A, Curtiss Goshawk. Complete Kits. Add 5c per Kit for packing charge.

All 8 for \$1. postpaid

Order yours at once—no stamps or C.O.D.'s. Send 5c for catalog of other Tropical Kits. DEALERS! CLUBS! Write immediately!

**TROPICAL MODEL AIRPLANE CO.**  
175 N. W. 31st Street  
MIAMI, FLORIDA

## LOUTREL AERO MOTOR

A Guaranteed Gasoline Motor, 1/5 H.P.  
Will fly 7-lb. model airplanes up to 10-ft. span

**NOW \$18**

A \$5 deposit will hold one of these marvelous motors on our easy payment plan. Send dime for literature on motor, planes, ignition, etc.

**LOUTREL SPECIALTY COMPANY**

785 Prospect Place, at Nostrand Avenue, Brooklyn, N. Y.  
• THOMPSON SUB MACHINE GUN •



Complete kit with machined barrel, magazine, necessary hardware and full-size working plans. Colt calibre 45 automatic pistol \$1.00. Postpaid, in U. S. A. No stamps, please. Checks 15c extra.  
**GUN MODEL CO., Dept. F, 2908 N. Nordica Av., Chicago, Ill.**  
Kits for all model guns 50c up.

# FREE!!



THIS FLYING MODEL  
of CURTISS NAVY  
RACER

with each  
**12 MONTH**  
SUBSCRIPTION to  
**MODEL**  
**AIRPLANE NEWS**

—The Magazine of the Hour in  
the Model Airplane field,

because of its timeliness, authenticity, consistent importance and news for model airplane builders. Here's value—figure it yourself—12 issues of Model Airplane News cost you 20c each at newsstands or \$2.40 for the year. Here's a saving of \$1.40 and in addition you get a complete 50c kit of a famous flying model. Mail This Coupon To-day!

THIS OFFER EXPIRES AUG. 6th.

JAY PUB. CO., 551 Fifth Ave., New York (FA)  
Enclosed find \$1.00. Send me Model Airplane News for 1 year. I am also to receive, FREE of cost, complete 50c kit to build a Flying Model of the Curtiss Navy Racer.

Name .....

Address .....

City ..... State .....

being passed with a vengeance. The phone at the Ninth Pursuit buzzed continually. The smell of burning insulation pervaded the orderly room as Major Rufus swapped verbal punches with the Wing.

"All right," he stormed. "Get me a plane that'll point straight down, stop in mid-air, and have a rock drill at its snout. Then we'll bore holes and lower dynamite into the holes. I'm sure all that could be done before the Boche ships stopped us. What? . . . Fresh, am I? Well, you birds aren't exactly in a state of dry rot . . . My job? Take it and welcome. Ha, ha! How's all your folks?"

"That is all we'll stand, major," the voice came back over the wire. "We want action! We want that place blown up, and the Air Corps is the only branch of the service that can do it . . . I'm a what? Garrity, don't you call me that! I'll have you a corporal by next week. I'll—you heard my orders!"

"If I was in the Sahara Desert without a phone," Garrity retorted, "I couldn't help but hear. So are you! I know the rules. You can't call me names, either. Good-bye! And don't forget to raise your blood pressure."

OVER on the Jerry side, Heinie Brass Hats were in better harmony.

"Das ist gut!" an overstuffed Herr Oberst chuckled as he watched a load of shells snake toward Mont Sec. "The Yangkee ships shouldt coom ofer yedt. Ve knock idt them down, hein? Efen beside der doomp idt giffs safe. Also idt iss der trap for Spadts und Camels mit bombers. Vhat they call der run ve gett der Dumkopsf on, ja?"

"You hear me say idt, nein?" gloated another Boche. "Ach, maybe das Pingham he vill made der trick vunce now. Ho, ho! Vunce iss idt I giff laughs by der oopstart. Und if he coom ofer, der Hauptmann von Bountz gets him mit all the Albatrosses. Schnapps, Herr Strongkoltz, giff here, ja!"

The Kraut was tipping a glass to his lips when props roared overhead. He and the Herr Oberst ran out to see a familiar-looking bunch of ships escorting two bombers to a layer of ether high above their heads. Wham! A bomb washed out a truck loaded with shells. The Heinies ducked.

"Das ist Pingham's Staffel," a squarehead ripped out. "Und giff ein look oop, mein Freund! Here comes idt der Albatross of Hauptmann von Bountz."

Upstairs in his Spad, Phineas saw them, too. "It's a new Von," he yelled. "I'll get him some day, but not today. Ow-w-w-w!"

Checkerboard ships fell out of the skies until Phineas thought the whole universe was dolled up in a checkered suit. He had spots before his eyes when he landed. When he walked to his hut, he was staggering a bit.

"Boys!" he exclaimed. "It's your move, Fritz! Ha, ha, I jumped you, an' I'm in the King row. Checkers is my meat. The Pinkhams—"

"I told you he was nuts," Casey said to an ack emma. "It ain't safe around

here. He'd ought to be in an asylum."

Mess in the Ninth Squadron was doleful in the extreme. The Old Man announced that his days were at an end, the same as Rollo's had been.

"While you buzzards were out wasting eggs, they came in here and said I would answer to charges in Chaumont for insulting my superiors. Well, I always wanted to get back home. Generally I put in my dahlia bulbs about this time."

"Why, we won't stand for it!" hollered Phineas. "Gosh, what fun would I have? Huh—maybe I'll get a C.O. without a sense of humor like yours, major. Cripes, just think of that!"

Garrity growled. His growl was cut short as his eyes fell on something that Phineas was toying with. It was a long, bleached bone, one end of which had been gnawed to a frazzle. At the moment, the miracle man was using it as a drum stick.

"What is that?" yelled Garrity. "Won't you leave even the garbage alone?"

"Wh-Why, there is sentiment attached to this," explained Phineas elaborately. "Y'see, Rollo left it in his hut. Funny how he gnawed it at this end. It looks like—now what does it look like? Lemme see, it looks like something. Haw-w-w-w-w! Rollo's teeth wasn't so hot. He had two upstairs and one down, and that is why he gnawed the bone this way. I guess I'll keep it with me always, as it is a memory of Rollo. It's his last will an' testament."

"Start chewing on it," barked Garrity. "You would look natural like an airedale."

"Major, I'm s'prised," sniffed the dog-fancier. "No sentiment, huh? Oh, well, I—huh, it's some bone. It is long enough to've come off a camel, but of course there ain't no camels in France. Anyways, it ain't big enough around to—"

"Shut up!" the major shouted. "Anybody'd think I was made a general instead of getting into a sling. Well, at least I'll be rid of you, Lieutenant Pinkham."

"I bet if somebody got that shell nest, they would change their minds about puttin' you in the benzine," chuckled Phineas complacently. "Somebody in the squadron—now I been thinkin'—"

"Oh, you have?" grated the Old Man. "Then I hope I'm busted fast. When you have a relapse and start thinking—say, Casey was in here a while ago. He wants a transfer. Says he doesn't feel good around a guy who washes out thread and hangs it up to dry. I gave him permission to carry an extra gun."

"Haw-w-w-w-w!" guffawed Phineas. "Don't that sound funny? Well, I have had plenty, and will bid you bums—and you, major—bong sore."

LIEUTENANT PINKHAM went to his hut and dug up some writing paper. "So the old turtle is headed for the benzine board, huh?" he muttered to himself. "First Rollo, then the Old Man. I don't know which one I'll miss the most. Well, I got to get this letter off." He wrote:



*Hauptmann von Bountz:*

"So you are the bum who is taking von Snout's place, are you? Haw! When bigger Vons are brought down, a Pinkham will shellac them. If you have no more sense than to do it, meet me over the Meuse at six p.m. tomorrow night. It will be amateur night for Kraut hams. Hoping the Kaiser and his family are down to their last pot of shoe button coffee, I am,

Most disrespectfully,  
LIEUTENANT PHINEAS PINKHAM."

"That is where we meet," grinned the letter writer. "But he won't force me down until I get over the shell nest." He yawned, put the letter in a tin can, dropped a stone in after it. Then he went to work rigging up a small parachute, the cloth for which he cut out of Bump Gillis' bed sheet. Having completed the job, Phineas picked up a book on Greek mythology and turned to a story about a man who found his way out of a labyrinth after slaying a dragon called the Minotaur.

"The Greeks must've drunk strong van rooge," Phineas, the kraut-slayer, observed. "Seein' things like that! But they weren't so dumb, just the same. Well—oh—ho—hm!" He turned over and went to sleep.

Phineas was up at dawn. He handed the tin can and parachute attachment to Wilson, leader of C Flight.

"Just drop it down over a reliable Heinie infantry outfit," he said, "so von Bountz will get a phone call. You'd think they'd open up the mails more with the Krauts. How can we call them names to make 'em mad? Haw-w-w-w!"

"How do I know it won't blow up on me?" Wilson wanted to know cagily.

"Aw, I'll open it and show ya," Phineas snapped. "I wish somebody'd stop gettin' suspicious of me. Gosh, if I should drop a hint where you was two nights ago! That Frog colonel's been tryin' to find who took his wife out an'—oh, well—"

"You blackmailer—give it here!" yipped Wilson.

C Flight took off and hopped into space. Phineas, whistling like that renowned barefoot boy, walked jauntily to the Frog farmhouse to get coffee. Only the mess attendant was in the place when he barged in.

"Ah—er—lootenant," Glad Tidings Goomer began. "Do you think the Old Man is leavin'? Ah—er—y'know, we enlisted guys git scraps of news from hither and yon. We heard they're goin' to send that Major Crabsby over from Issoudun."

Phineas immediately lost his zest for java. He had never forgotten Major Crabsby.

"Goomer," he snorted as he left the mess room, "if you ever have good news, it'll kill ya. You would sure laugh if you bumped into a good trunk murder. Adoo!"

"That is that!" Phineas muttered to himself as he tramped across the field. "It's either I go West or work for Crabsby. Horace Greeley wins."

Contrary to his chief pain in the neck, the Old Man was late for breakfast that morning. He asked somebody for an old leather strap. His trunk had

become a trifle senile, and needed additional means of support.

"Packin'?" inquired Phineas Pinkham. "Why—er—while there is life, there is hope. I wouldn't be hasty, major. All the guys'll sign a petition an'—"

"I'll resign," cracked Garrity. "If those fatheads think they can benzine me, well—it's somethin' to have been here."

Wilson came in with his flight five minutes later and reported quite a pasting. He also said that he had seen a D.H. knocked off north of Mont Sec. There had been a pretty semi-circle of Kraut anti-aircraft about the spot where the shell dump was located, and they had not been shooting iron filings.

"Who wants a petition?" growled the Old Man. "Ha, ha! Well, I'll send you all a postcard or two."

A load of Chaumont's itinerant Brass Hats blew in toward mid-afternoon. Phineas watched them arrive as he stood in the door of his hut. Screwing up his homely face, he turned and began to make ready for his date with von Bountz. He picked up a big spool of black thread, tied a white object to a loose end. It was about the shape of a galloping domino and about two inches square. He put the spool into the pocket of his leather flying coat just as Bump Gillis came in, wiping his brow.

"The Brass Hats are all gaga," Bump told Phineas. "When the Heinies start throwin' them shells—ugh! They told the C.O. that the biggest generals were back-pedalin' already. Looks like they'll set up quarters in the shadow of the Pyrenees. The Old Man insulted another big Brass Hat, as if he wasn't sure he'd done enough. Carbuncle, do ya think we could get transferred to teach new guys to fly?"

"That's always the way," Phineas derided him. "Everybody despairs in times of stress but a Pinkham. Once in the Mexican War, my uncle ran up to the enemy lines an' shoved a hand in the muzzle of a Mexican cannon an' held back the grapeshot while the U.S. soldiers—"

"Aw, rats!" Bump Gillis bawled at him, and stamped out again.

THE Ninth wondered why Phineas Pinkham was absent from mess that night. But the pilots stopped wondering when they heard a Hisso turn over. Phineas was driving the Spad across the field by the time the Old Man had dived out of the house.

"Ha, ha!" Major Garrity laughed. "See if it bothers me this time. I am resigning tonight. I just have to think how I'll word it. Adoo, Mr. Pinkham, and if you break anything, be sure it's your neck."

"Huh!" grunted Captain Howell. "If he does, he'll splint it up with a broom handle and live to be a hundred an' two. I'm goin' out an' get boiled to the ears."

Herr Hauptmann von Bountz was waiting for Phineas over the Meuse at the appointed time. In fact, he was three minutes early. The pilot from Boone-town spotted the Kraut and edged off

# CLEVELAND

## 3/4" SCALE FLYING MODELS

"The Last Word in Flying Models"

Here are 3 marvelous summer fliers—from the famous C-D 3/4" line of 50. Authentic in detail—beautiful in design—a real pride to own. Kits are super complete—super-detailed, full size drawings, printed out wood, partly finished parts, pilot blocks, scale prop as well as flying prop, authentic rib and stringer material, etc.



Kit SF-35 55 1/2" BOEING 247 .....\$8.50

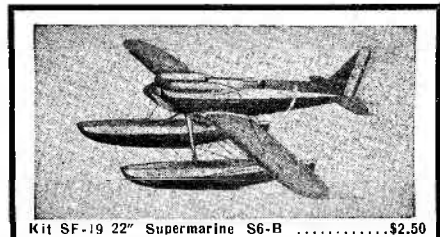

Kit SF-19 22" Supermarine S6-B .....\$2.50

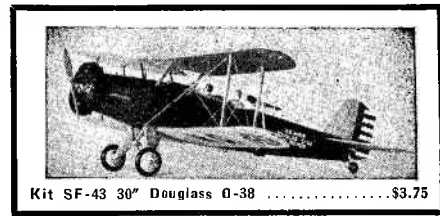

Kit SF-43 30" Douglas O-38 .....\$3.75

# CLEVELAND

## 1/2" SCALE FLYING MODELS

"The Sensation of the Model World"

29 in all. Identically same as the 3/4" line—except smaller, and Kits contain NO LIQUIDS. If ordering less than 6 by mail, 10c per Kit must be added to these prices to cover handling charges.



15" Hi. Speed Fury.. 45c



14 1/2" Boeing P26... 65c



15" Boeing P12E.... 65c



14" Quad Fight.... 45c



22-3/16" Boeing 95. 85c



11 1/2" Fokker Tripe.. 45c

AS NEW C-D DEALERS ARE BEING APPOINTED DAILY  
**Your Dealer May Have These**

so go there first. If he hasn't, order direct, giving his name and type of store (hardware, dept., sporting goods, etc.). Send check or M.O.—no C.O.D.'s. Canada, Mexico, British Isles, add 10% to all prices; other countries, 20%.

Catalog of all 50 C-D 3/4" models, C-D supreme supplies, and 29 C-D 1/2" models, mailed anywhere upon receipt of 5c. Send for it.  
DEALERS! CLUBS! SCHOOLS! Write at once!

# CLEVELAND

MODEL & SUPPLY CO., Inc.

1866FAH West 57th Street, Cleveland, Ohio

**For Summer Fun!**



**5 ft. Size**  
Your Choice of  
Stinson Reliant  
Monocoupe-Warner 110  
Heath Parosol

**Giant Flying Models**

**\$1.50 Each**  
for \$1.50 Postpaid

These Giant Models are the Marvels of Modeldom wherever seen. Each comes in a complete Kit with everything needed, including a semi-finished propeller. Sent postpaid for only \$1.50. Same Kit, with an extra, fully finished, 15 in. Paulownia Wood "I M P" Propeller (value 80c) sent postpaid for only \$2.00.

**12 in. Solid REPLICA MODELS**  
**6 Famous Ships**



DeHavilland Comet—Ryan Racer—Martin Bomber—Sikorsky Amph.—Douglas Airliner—Boeing 247D

Big value Kits, each containing full-size Plans, details and instructions, printed balsa, fuselage block, pontoon blocks, wheels, stamped alum. props, cement, bamboo, colored insignia and water colors with brush for decorating the Model. Everything you need to make a wonderful Replica Model.

Your choice of any 3 Kits for **50c**

Postpaid



**WITHOUT THIS LABEL**  
For Performance and Appearance always use the Genuine

**"PAULOWNIA" WOOD PROPELLERS**

(Reg. Pend.)  
"As light as Balsa with Twice the Strength"  
Accurately carved and beautifully finished by hand. Guaranteed true; made in Standard, Navy Helical, Steel Type and other popular styles, from 5 in. to 20 in. size. Tested and approved by Junior Birdmen Institute.

Send 3c for Propeller Guide  
Now Sold by Leading Dealers, Dept. Stores and Specialty Shops. Ask for "IMP" Paulownia Wood Propellers and Accessories.

**INTERNATIONAL MODELS COMPANY**  
1781 Broadway, General Motors Bldg., New York

**LINDBERG LINE**



Fokker D-8 Span 15"

**JOBBER! DEALER!**

Handle Lindberg Kits They Will Give You Repeat Orders.

WRITE FOR FULL INFORMATION AND ILLUSTRATED CATALOG

**LINDBERG MODEL & SUPPLY CO.**

5324-28 N. Kedzie Ave. Chicago, Ill., U.S.A.

**FREE ARMY FLYING TRAINING**

Air Corps Cadets get 300 hours solo flying, with salary, expenses paid. Information pamphlet, how to apply, 20c. Same information on Navy Aviation training, 20c. Information on Marine Corps Aviation, 20c. All three for 40c. Pamphlets prepared by Air Corps Veteran. USED AIRPLANES, GLIDERS, \$40 up. Literature 10c.

**CONTINENTAL SALES CO.**  
Box 344-C Indianapolis, Ind.

**BE A DETECTIVE**

**Make Secret Investigations**

Earn Big Money. Work home or travel. Fascinating work. Experience unnecessary. **DETECTIVE** Particulars FREE, write to **GEO. G. WAGNER, 2640 Broadway, N. Y.**

**HAY FEVER**

ASTHMA and SUMMER COLDS are unnecessary. Complete relief only \$1.00 Postpaid. Nothing else to buy. Over 40,000 HOLFORD'S WONDER INHALERS sold last year alone. Mail \$1.00 today for full season's relief to THE DANDEE CO., 252 HENNEPIN AVENUE, MINNEAPOLIS, MINNESOTA, or write for Free Booklet.

his course a bit.

"That's what I like—punctuality," grinned the errant Yank.

In the succeeding five minutes, it became glaringly apparent to Phineas that von Bountz must have been transported to his fond parents on the back of an Albatross and not of a stork. He was a born disciple of homicide, and no mistake. Phineas had cause to wonder if each of the Spandaus on the Heinie crate had become twins. Two guns simply could not spill out so much lead.

"It's a cinch I don't fly back in this Spad," he gulped, as he miraculously rocked out of the path of a bunch of slugs that would have made a lace doily out of a battleship turret. Yet all the while, Herr Pinkham was crabbing across sky space until he was directly over Mont Sec.

Von Bountz knocked a mid-wing strut loose from the Spad with another quick left hook, and Phineas tried to cover up, but another Spandau uppercut got under his guard and snapped the Spad's chin up. Smoke curled from the Yankee ship's snout.

"Oh, boys, the fathead is sure ahead on points," the intrepid flying jokesmith howled. Then he headed for the carpet. "Why, there's a truck pullin' up down there. That's the spot! I wouldn't forget that. And there are about twenty Krauts in front of the big cave. Well, I'll signal for a fair catch."

"Ach!" yowled von Bountz deliriously. "Such ein mark easy, ja! Und der oopstardt alzo iss der vun what knocked down all the bick Rittmeisters. Ho, ho, they moost haff got der sleepink signess, alzo. Like der iron stag on der grass he flies, ho, ho! Famous ofer night I ben. Der Kaiser—"

Phineas landed his Spad in the road, spun around twice and cracked up against a Jerry truck. Seven of the Kaiser's boys hopped on him the minute he crawled out of his ship.

"Oh, I say, uncle," the fearless Yank gurgled from the bottom of the heap. "I am kapoot!"

WHEN they stood him up, Phineas leaned against the truck's remains. It was loaded with shells. From the back end of it he caught sight of wisps of heavy dry straw. Evidently, the fast-thinking Spad pusher mused, it was the straw that had helped prevent shock to the shells on the bumpy roads—and when his Spad had collided with the truck. Phineas' hand moved from his pocket to the truck, then back again. Von Bountz came running up, big square face split with a fiendish grin.

"Pingham," he chortled. "He iss so smardt, hein? Der first time yedt, I gedt him." The guttural tones were mocking.

"Der Tag iss it," Phineas said sheepishly.

"Ve shoodt him now," cracked a pompous Herr Oberst who had rolled up in a car. "Nein, ve take idt chances no more. Ve shoodt him deadt."

"Ach, he iss der prisoner of var," protested another squarehead. "He iss nodt der spy. Already yedt ve get called butchers mit knifes too mooch. Der



**TAKE YOUR PICK—EITHER ABSOLUTELY FREE!**

SO great was the demand for the F.A.C. ring that we not only had to order another supply, but we decided to add the beautiful silver finished Identification Bracelet pictured above. The ring, finished in antique silver, is self-adjustable and guaranteed to fit, while the bracelet is equally attractive.

To get either of these awards ABSOLUTELY FREE, it is only necessary to send us ONE YEARLY SUBSCRIPTION to FLYING ACES. If you are not a subscriber, send us your own; if you already take the magazine, your subscription can be extended. If you want to get one of your friends to subscribe, you'll find that an easy matter. Just tell a little about YOUR magazine—its thrilling stories, interesting features, those complete and up-to-date model building plans, rare photos and valuable data. Tell what you have learned from FLYING ACES, and don't fail to point out that at \$1.50 a year, FLYING ACES offers more than any other magazine in its field. Bring out the fact that FLYING ACES is really THREE MAGAZINES IN ONE—a Model Building Magazine, an Aviation Fact Magazine, and an Aviation Fiction magazine.

SEND FOR THE RING OR BRACELET AT ONCE! How long our present supply will last we do not know. Of course, we'll sell you either ring or bracelet for 50c, but why buy one when you can have either for just one subscription to FLYING ACES?

*This offer good only in U. S. and possessions*

SUBSCRIPTION DEPT., FLYING ACES,  
67 West 44th St., New York City.

Gentlemen:—

I'm taking you up on your offer! Please enter the following subscription to FLYING ACES for which I enclose my (check) (money order) in the amount of \$1.50.

Name .....

Street & No. ....

City & State .....

Please send the article which I have checked to the address below:—  
 Ring  Bracelet

(Your Name)

(Address)

(City & State)

plan iss idt I haff." Suddenly he spun his head toward the truck. "Schnell!" he rapped out sharply. "Take idt der truck in der cave mout'. After ve eat, ve unloadt. Do you vant idt shouldt be oudt where der bomber might make it der hit, Dumkopfs?"

"But Pingham he must be shot," argued the Herr Oberst. "Orders yedt iss—"

"Lizzen vunce, und don't you shouldt laugh," von Bountz whispered to the Herr Oberst. "Oudt by der field idt iss der Allied two-seater ship, ja. Ve put Leutnant Pingham by der stable und tie him oop loose, ja? Der two-seater will be varmed oop, und he tries der escape, nein?"

"Ach, Gott!" chuckled the officer. "Das ist gut. Ho, ho! Ve stardt idt der shooting when he sticks his head oudt—"

"Nein," denied von Bountz. "I must shoodt him und kill him by mineself. Mine he iss, so! Listen vunce—I, von Bountz, shoodts Pingham down zwei times in vun day. I am der hero."

"Bah! Und maybe he gedts away, alzo. Nein, Hauptmann, it giffs foolishments. Many times der Leutnant escapes—"

"But vait," gloated von Bountz. "I haff fixed idt der stick by der ship. Idt iss only vun by der back pit, ja. Der pilot's stick iss broke by der socket. When he gedts in und goes maybe fifty feet oop, der stick idt—poof! Pingham he vill see der trick, nein? I bedt you idt iss many flowers by der funeral, ho, ho!"

"I wish I could laugh, too," yipped Phineas. "I like a good story. Did you ever hear the one about the old maid who—"

But they sent Phineas reeling away toward the Hun jail with a shove that would have made a tank go spinning.

"No sense of humor," complained the pilot from Boonetown, Iowa, in the good old U.S.A. But he grinned, nevertheless. He kept his hand in his pocket all the way, turning his head at times to look back. As he was shoved into a smelly stable, Phineas heard the truck clatter to life and saw it roll to the entrance of the great shell cavity.

"I just hope the book was right," he said to himself, and sat down. "I'm glad it's dark. I'm glad nobody saw the thread. In fact, I'm glad about everythin' but bein' here. Why—huh—there's a two-seater out there, an' somebody is warmin' it up. Hm-m!"

Three squareheads came in then. Under von Bountz's supervision, they bound the Pinkham appendages and then departed.

"They must be underfed, as I have heard," grinned the prisoner. "These ropes wouldn't worry Cinderella very much. They're too sure of me, as usual. Will they ever learn?" He began to wriggle. The bonds at his ankles loosened. After a while, Phineas was free. He looked out of the window, then felt of the good luck bone in the pocket of his flying coat.

"Good ol' Rollo," he grinned. "It's good luck, huh?" Mentally he measured the distance between the stable and the

two-seater that was ticking over. He noticed that the squareheads around the shell nest were very lackadaisical. "Well, there's no time like now!" he yipped. "Most of the bums'll be eatin'. Here goes history."

He took a wooden spool from his pocket, snapped off the thread tied to it and lighted the end. The night air was quite chill in Boche territory, and three groups of Huns were crouched about crackling fires. The little fiery sparks from the Pinkham fuse should not be noticed. Then, too, his break for the two-seater would draw undivided attention.

"One—two—three!" counted Phineas, then broke open the door and started running.

VON BOUNTZ, standing by his plane, chuckled. "He bites der bait. Ach, vill he gedt idt der surprize. Soon I give idt der signal for soldiers to shoodt und miss. Ho, ho, he iss in der ship now, und there he iss joompink by der back seat, ja!" He raised a hand and guns barked. Bullets missed Phineas by feet and yards.

"Too mooch Schnapps!" the Boone-town pilot howled mockingly as he leaped into the rear pit. "I hope there's a stick here, as—"

Von Bountz yelled like a hog-caller as he got into his Albatross. Phineas goosed the D.H. engine and felt the ship roll over the bumpy ground.

"Aduo!" he hollered. "Haw-w-w-w! Well—uh—cripes!" The stick came loose in his hand, and the D.H. was accelerating speed. Heinies still played their part by wasting the Kaiser's ammo. A machine gun dug up dirt around the D.H.'s undercarriage.

"No stick—oh, the dirty bums!" groaned Phineas. "I catch on. That is no fair. Well, I—" Suddenly he reached into his pocket and pulled out Rollo's bone. The gnawed end of it which had intrigued him back at the home drome fitted into the socket in the floor. He yanked back on it, felt the two-seater rise.

"Haw-w-w-w-w!" Phineas' guffaw was an ululation. "It's a good thing Rollo had three teeth. If it'll only hold—if it breaks—well—hah!"

Von Bounce was up now. His Albatross zoomed over the top of the cliff housing the shells. And as his undercarriage missed it by not more than three feet, a noise like the merger of seven thunder claps shook the Kraut real estate just as if it were so much tapioca pudding. The truck had blown up. The sympathetic nerves of the shells inside the cave bucked. The top of the cliff heaved up.

One rock, half as big as a National Bank, nudged against the tail of von Bountz's battle bus, and the Hauptmann was lucky to land the remains in a swamp. As he stood waist deep in mud and water, he looked up to see Phineas' two-seater flying sluggishly toward the Allied lines.

"Der defil he iss," he moaned. "I zaw him t'row oudt der stick, und yedt he flies. Ach, Himmel! Und der shell doomp idt is kaput. How ist das?"

## SCIENTIFIC SCORES AGAIN!

Introducing  
**4 NEW MODELS**  
in the famous line of  
**20" HI-FLYERS**

with the Exclusive Scientific Feature  
**Bridge-Type Landing Gear**

New for the first time Scientific presents these new models. Positively the last word in accuracy, completeness, flying quality and of course Value! Never has Scientific offered so much for so low a price! You'll like the bridge type landing gear which makes for sturdiness and cuts down possible damage from crack-ups. Another feature is the 3-color gummed insignia sheets. Buy them at your dealer or order direct today!

**50c**  
EACH  
POST  
PAID

**GUARANTEED TO FLY**

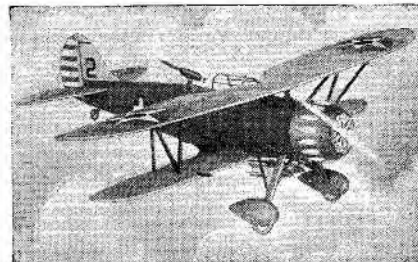

20" WACO MODEL "D" MILITARY 50c Postpaid

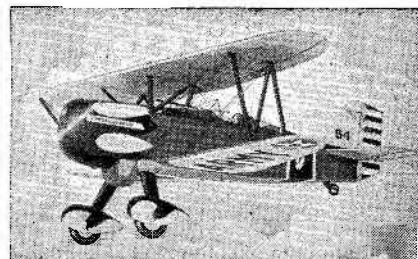

20" CURTISS P6-E ARMY HAWK 50c Postpaid

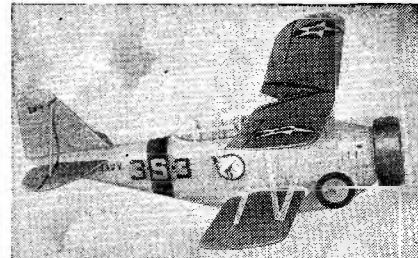

20" GRUMMAN FIGHTER SF-1 50c Postpaid

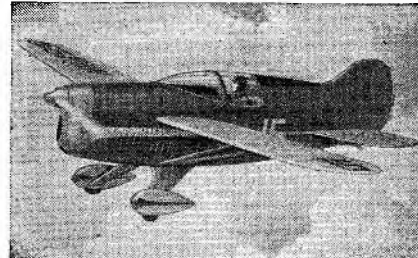

20" ART CHESTER RACER 50c Postpaid

20-page, 1935 Catalog FREE: send 3c stamp postage  
DEALERS: write for discounts

**SCIENTIFIC MODEL AIRPLANE CO.**

218-220 F8 Market St., Newark, New Jersey

**Here's Why**

# LINCOLN

**Training**  
Qualifies You for Success  
in **AVIATION**



Aviation offers a romantic career with big pay opportunities to young men who are properly trained. Come to Lincoln and train for aviation success. This school is GOVERNMENT APPROVED, is thoroughly and modernly equipped and has Government licensed instructors.

**Earn Good Pay As Master Airplane and Engine Mechanic—**

Finest practical training overhauling and rebuilding Whirlwinds, Wasps, Cyclones, Aircraft Diesels and many other aircraft engines. Practical experience in rebuilding modern airplanes under factory standards. Training also includes aerial radio, welding, instrument repair, machine shop practice. Prepares you for good pay jobs offered by airline companies and factories.

**How Would You Like to Earn \$6.00 An Hour As Transport Pilot, or start as Limited Commercial, Private or Amateur Pilot. We train you for Government License for either one. Modern equipment includes high and low wing monoplanes, biplanes, cabin planes and others to assure you complete experience. You learn straight flying, night flying, blind flying by instrument, aerobatics, cross country flying, etc. Highest type Gov't. License instructor.**

**Let LINCOLN Qualify YOU for Successful Aviation Career—**Lincoln graduates being placed with best known companies in Aviation Industry. Big pay opportunities in Central and South America as well as in United States for those who start now. Don't wait! Write now for complete information. Please state your age.

**LINCOLN Airplane & Flying SCHOOL**  
2032A Aircraft Bldg. Lincoln, Nebraska

Aviation offers a romantic career with big pay opportunities to young men who are properly trained. Come to Lincoln and train for aviation success. This school is GOVERNMENT APPROVED, is thoroughly and modernly equipped and has Government licensed instructors.

Finest practical training overhauling and rebuilding Whirlwinds, Wasps, Cyclones, Aircraft Diesels and many other aircraft engines. Practical experience in rebuilding modern airplanes under factory standards. Training also includes aerial radio, welding, instrument repair, machine shop practice. Prepares you for good pay jobs offered by airline companies and factories.

How Would You Like to Earn \$6.00 An Hour As Transport Pilot, or start as Limited Commercial, Private or Amateur Pilot. We train you for Government License for either one. Modern equipment includes high and low wing monoplanes, biplanes, cabin planes and others to assure you complete experience. You learn straight flying, night flying, blind flying by instrument, aerobatics, cross country flying, etc. Highest type Gov't. License instructor.

Let LINCOLN Qualify YOU for Successful Aviation Career—Lincoln graduates being placed with best known companies in Aviation Industry. Big pay opportunities in Central and South America as well as in United States for those who start now. Don't wait! Write now for complete information. Please state your age.

**LINCOLN Airplane & Flying SCHOOL**  
2032A Aircraft Bldg. Lincoln, Nebraska

**Build this 36" speedy deluxe flyer out of your own materials**



You save 2 3/4 ordinary cost—no kit needed. Every one a wild about the great KDS CLOUD KING. It's a real sensation. Files 800 feet. Ideal for summer flying. Rush 35c plus 3c stamp for postage AT ONCE for full size plan and template sheet including trimmings. Send TODAY to avoid disappointment

**DORIN PLAN & SUPPLY CO., 10326 Main, Detroit, Mich.**

**NOW CLUB MEMBERS**  
**PUT YOUR IDEAS INTO FORM**  
WITH A



**BROWN MOTOR**

**HIGH POWER — — MORE SPEED**  
Build your models to a size that will enable you to prove out your ideas, something practical (5 to 10 feet wing spread) and power them with a

**REAL MOTOR — GUARANTEED TO RUN**

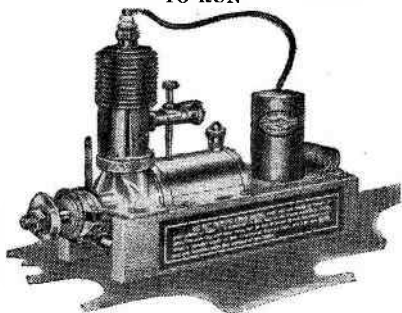

Design and Construction Fully Covered by Patents Pending.

**DISTRIBUTORS FOR GREAT BRITAIN:—**  
**STUART TURNER, LTD.**  
Henley-on-Thames, Oxon, England.

For detailed information, prices, etc. See your dealer, or Communicate direct, with

**JUNIOR MOTORS CORPORATION**  
Broad Street Station Bldg., Philadelphia, Pa.

An Herr Oberst, recovering from a brain spin, wanted to know, too. "He haff der fuse to der truck!" he yowled at an Unteroffizier. "You don't see it, hein? Blind you are, ja! Look vunce. All ist lost. Der Yangkee he cooms down joost to blow oop der doomp. Und yedt he flies mitout der stick. Idt giffs craziness. I quit und go back by Dresden. Back I coom vhen das Pingham he iss hung by the heels in a Hamburg butcher shop, und not undil then. Donnervetter, I could joost sit down like der Fraulein und cry. All the shells—kaput. Vhere iss idt das von Bountz? I bedt you I fix der bummer. Bah, he iss so—"

And while anguish reigned in Kraut circles, Phineas Pinkham, flying not more than twenty feet up, goosed the D.H. toward home and Garrity, his lips muttering a prayer as he held Rollo's bone gingerly in the socket in the floor. "If I don't meet Vons and have to stunt, I'll make it," he palpitated. "As long as—crises!"

Crash! Bangety-bang! Blam — bo-o-o-ong!

"Well, the shells'll have to hit me, as I would have to climb up to meet the shrapnel, haw-w-w-w-w! I—oh-h-ow!" Machine-gun bullets spat at him from the trenches. The D. H. seemed to be towing a concrete mixer as it skimmed the Jerry ditches.

Phineas goosed the engine to the limit, finally left hostile trenches behind. Then Rollo's last will and testament snapped. The Yank gritted his teeth and climbed to the edge of the pit as the D. H. swooped down like a hawk that has spotted a plump pullet without a chaperon. A wing whanged against a ruined church steeple. The D.H. spun around in the air, changed it. tactics and nosed for the ground. But Phineas was not in it when it landed. He was hanging from his coat collar at the end of a beam sticking out of the old church spire.

"I don't know how I got here," he muttered, "but here I am. I wish somebody'd bring me a ladder. He-e-e-lp!" There came a sickening sound as the supports of the beam began to protest. Phineas felt the beam sag. Then it dropped with a jolt, and he was shaken loose. This time, he landed in a tree.

"It's a hell of a time I am havin' to get down," Phineas complained. "Anybody but a Pinkham would git discouraged." He clambered down the rest of

the way and stretched himself out on the ground.

Toward dawn, he woke up and felt the cold edge of a spade pat him on the cheek. He looked up and saw a rectangular patch of sunlight. An angleworm crawled across the bridge of his nose. An assortment of faces looked down at him. He sat up with a jerk.

"Why," yipped the man who refused to go West, "you—you was buryin' me! Why, you bums! I'll bust you for this."

"Well, ya looked dead," a tough dough growled at him as he helped Phineas out. "I still ain't sure you ain't. Now we wasted a lot of our time an'—"

IN the middle of the forenoon, a truck dumped Phineas Pinkham, the errant knight, onto the drome of the Ninth Pursuit Squadron.

"Do ya think this is where ya dump garbage?" Bump Gillis hollered. "You pick up that stuff an' git to—"

"Haw-w-w-w-w!" guffawed Phineas, wiping mud from his face. "Always clownin', huh, Bump?"

"Carbuncle! Well I'm a—say, you didn't blow up that dump? We got word. Oh, no, you been on a bat. That is what. Wait until the Old Man—"

"Why," Phineas told Garrity later, "I made that fuse. You just boil strong thread in oil an' brimstone an' orpiment an' let it dry. Then it'll burn. I shoved the block of cellerloid into the straw in the truck, an' when I walked away, I just let out the thread. Just like the Greek in the labyrinth. I set fire to the thread an' then got to hell out. Well, you'll get a medal now, major, instead of a bath in benzine. Haw-w-w-w!"

"How did you git back?"

"In a two-seater," Phineas explained. "There wasn't a stick in it, but I just used that bone Rollo left us. Well, I really must go now an' git my rest. Even a Pinkham's nerves have their limits. Adoo!"

"Just let him go," whispered the C.O. "Maybe he'll be all right in the morning. You'd be nutty, too, if—"

The fact that the wreck of a D.H. had not been set afire and had later been closely examined by Major Garrity himself who could find no trace of a control stick was all that saved Phineas Pinkham from a cell lined with cushions. For weeks afterwards, Bump Gillis slept with two guns under his pillow.

## Calling All Planes

(Continued from page 15)

"All right, lieutenant. Now listen. These people—a woman and her baby, and eight miners—have been marooned for days in a little shack up in the Golden Gate Mountains. Heavy snows have been falling most of the time, and they're snowbound plenty. Trails are all drifted over and there's no way in the world of getting food and fuel to them except by air—and even that's going to be a helluva job because they're

right in the mountains and there's no landing field in a hundred miles of there."

"Okay. I'm still listening."

"Well, if you've got a flyer who'll take a chance on his neck—and it is a chance, for there are storm signs aplenty—have him fly up here in a big ship and I'll load him with food and other stuff to take over and drop to them—if he's lucky."

March Field quickly proved that it was foster-mother to more than one flyer who'd take a chance on his neck, even under such conditions. Practically every pilot on the field volunteered for the job of flying the huge Condor bomber that was wheeled out on the line.

Pilot Lieutenants Joseph A. Miller and Cedric J. Brockliss were the lucky chaps. For Miller, at least, the task of shoving that big crate over mountain country held no fears. Lieutenant Miller is a native of the Badlands country up in the Dakotas. Lieutenant Brockliss, too, has seen enough of the Wild West for him to look upon mountain flights as mere routine matters.

For two hundred miles they flew in a northeasterly direction, crossing some of the roughest country in the United States. Up through San Bernadino County and bucking the great San Bernadino Mountains, across the deserts that reflected blast-furnace heats, over the forests of oil derricks, touching a corner of dreaded Death Valley, across the Kingston and finally across the Spring Mountain Range, the two flyers pushed their gigantic Condor. Then down at Las Vegas, where the mining man who had called the Army field at Riverside supplied them with 100-pound "bombs" in the shape of tightly lashed, padded bundles of food and other supplies. With these snapped into their bomb-shackles, and further instructions on how to find the marooned party, the birdmen persuaded their heavy boat from the ground and aimed her at a point marked on their map by the mining man.

It was good flying opposed to terrible flying weather. No sooner had they left Las Vegas than they realized that a terrific job was before them.

But—Lieutenants Miller and Brockliss delivered the goods. Buffeted by storm winds and menaced by the up-flung peaks of the razor-tipped mountains, they nevertheless found their way to the little snowbound cabin in the Golden Gates. They laid their eggs—real eggs, this time, in some of the bundles—by yanking at their bomb toggles in true bombardment manner. All bundles fell within a very small radius of the cabin, and their contents served to succor the marooned group until help reached them *via* the trail.

**T**HIS job in the west was just one of the emergency jobs that are constantly cropping up for the Army flyers. Another incident, much more unique, was the utilization some months ago of an Army bombing ship in dropping a house on a mountain top. Believe it or not!

This incident occurred in the Hawaiian Islands when the Chief Forester of the Hawaiian Territory decided to build an overnight station for his rangers on the summit of a peak in Koolau Range, in the Kaipapau Forest Reserve on Oahu, largest island of the Hawaiian Group. When he was ready to begin actual construction, he found that it was almost impossible to transport the twelve-hundred-odd pounds of lumber, sheet iron, nails and other ma-

# Gold Seal Cockpit Control

## Soars Out of Our Model Hangar to You \$1

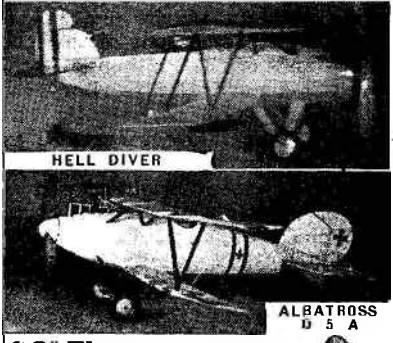

For real fun there isn't anything to beat model building... don't let anyone tell you or sell you an idea that does most of the work... why pay for labor and eliminate the fun. This Gold Seal fleet of 24" flying models have new cockpit control. Control wires are designed not to interfere with rubber motor. Kit contains all horns, pulleys and hinges ready made. 3/4 finished wheel pants, two colors tissue, all parts printed on balsa, aluminum spun cowl, finished propeller and the most simplified ABC plans you ever saw with complete instructions, cement, dope, etc. These 6 models to choose from: Curtiss Swift, Spad, Douglas O38, Albatross D 5 A, Hell Diver, Stinson Reliant,

POSTAGE 15c EXTRA

**\$1.00 Ea.**  
(postage 15c extra).



### 16" Flyers FAIRCHILD 22

Contains printed balsa parts, two colors tissue, wheels, wire, rubber, wood veneer, full-size plan, dope, cement, etc. 8 models to choose from: Goshawk, Fokker Triplane, Fokker D-1, Fairchild, Curtiss Falcon, Howard Ike, Waco, Nieuport.



**30c Ea.**  
POSTPAID

### 6" to 8" REPLICA MODELS

Geo Bee, Sikorsky Amphibian, Mystery S, Racer, Fairchild 24, Howard Racer, Boeing P-12C, Nieuport 17, C-1, Curtiss Hawk P 6E, Savoia Marchetti, Fokker D-VII, Sopwith Triplane, Spad, Northrop Gamma, Supermarine, S-E 5, Pfalz, De Havilland IV, Lockheed Vega, Hell Diver, Waco, Albatross.



**15c Ea.**  
Postpaid

**HOW TO ORDER**  
Send name and address. Enclose amount and postage. Canada 10c Extra

Mention planes wanted. FREE—Send for Price List of Supplies Dealers! Send for Price List

### 12" SOLID REPLICA MODELS

With die-cast propeller, two bottles color, cement, printed balsa parts, etc. 10 models to choose from: Douglass, Geo Bee, Fairchild 24, Bristol Fighter, Monocoupe, Spad, Aeronca, Boeing X P 936, Stinson, Flamingo.

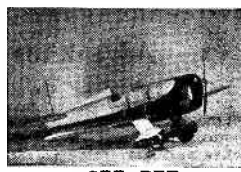

**30c Post-Ea. paid**

### 12" FLYING SCALE MODELS

Contains printed parts, wheels, cement, rubber, prop block, tissue, etc. Eight models to choose from: P. T. Army Trainer, DeHavilland, Hell Diver, Monocoupe, Boeing Bomber, Arrow Sportster, Spad, Geo Bee D, 15c each, postpaid.

## CONSTRUCT-A-PLANE CO.

738 Grand St., Dept. 108, Brooklyn, N.Y.

### BUILD THIS CONSOLIDATED P30 IT IS A DANDY—YOU'LL LIKE IT

**ALL KITS 50c EACH**

**4 for \$1.50**



Our KITS are all authentic 1/4" scale Models. Complete in every detail. You will be pleased with our models. They are easy to build—wood parts cut to outline shape, correct scale plans. Die cast props, machine guns and wheels. We have 37 different models, here are a few:

Bristol Fighter	Navy Racer	DeHavilland 4
B/J Seaplane	S.E.5A	DeHavilland 5
Curtiss Racer	Fokker D7	Monocoupe
Nieuport 17	Fokker D8	Camel
Hawker Fury	Vought V65	F.E.2.B

ADD 10% FOR POSTAGE  
**HAWK MODEL AIRPLANES**  
4946 Irving Park Blvd., Dept. F12, Chicago, Ill.

terial up the steep mountain passes. Treacherous winds, changing often, prevented all but the most sure-footed of mountain goats from freely traveling the trails. Even forest rangers often found it necessary to creep along certain stretches. The pack burros, usually as confident as the goats, refused even to make the attempt to climb with loads, hence it began to look as though any ranger unfortunately enough to be caught on the peak would have to sleep as best he could.

One ranger, however, had seen some of the Army bombers at practice. "If they can drop bombs of explosive right where they want them," he said, "why can't they drop bombs of lumber and sheet iron?"

The commanding officer at Luke Field was contacted and gave his consent to a trial. Master Sergeant Samuel J. Davis, one of the few enlisted pilots in the Army, and a member of the 23rd Bombardment Squadron at Luke Field, was given the chance to try his hand at the job.

Flying a standard bombing ship, he took off with the three bulky bundles of building material swinging from the bomb shackles underneath the wings. Up he went, and in spite of adverse weather and flying conditions, he succeeded in dropping his burden in the two-hundred-yard clearing atop the mountain. Altogether, including the time spent in preparation for his hop and the hop itself, he accomplished in just six hours a task that would have

## Distributors for PGH

"America's Finest Solid Scale Models"

wanted for DETROIT (and surrounding), CLEVELAND-COLUMBUS (and surrounding), CHICAGO (and surrounding), NEW YORK (and surrounding), PHILADELPHIA (and surrounding). Write on your letterhead for list of dealers available in these rich territories, and value of distributing the fast-selling PGH. Kits.

**PGH. Scale Model Airplane & Supply Co.**  
635 Penn Ave., Dept. F-1, Pittsburgh, Pa.

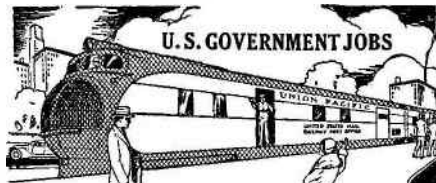

### \$158.00 Month Railway Postal Clerks

**First Year Regular Men 18 to 35**

FRANKLIN INSTITUTE  
Dept. W257, Rochester, N. Y.

Sirs: Rush without charge. (1) 32-page book describing many U. S. Government jobs. (2) Send list of Government jobs for men-women.

Mail Coupon Today Name \_\_\_\_\_ Address \_\_\_\_\_

**Ready Now!**

## The Junior AIRCRAFT YEAR BOOK for 1935

### Attention! Model Builders!

Every available American commercial, military and naval plane now produced is represented here by 79 3-view drawings prepared especially for this book by the manufacturers themselves. There also are 12 chapters and 150 pictures in this book of 256 pages.

### Adventures in the Air

The story of all the great adventurous flights of 1934, with pictures. Interesting facts about how Uncle Sam is using aircraft — chasing smugglers and hunting handits in airplanes, fire patrol over the forests, daring rescues at sea, aerial surveying and many other thrilling activities.

How the heroes of the Army, Navy, Marine Corps, Coast Guard and Border Patrol meet adventure every day and night.

### Making Good On the Air Lines

How the air lines are operated. How young men are making careers in this business of flying passengers, express and mail throughout the world, over land and sea. Illustrated by photos taken for this book.

### Keeping the Airways Open

The fascinating story of a new business for young men, with something doing every minute at the airports and along the airways, the high-ways of the sky, with their radio control and flashing beacons.

### New Things in the Air

The story of the new American planes and engines; and what young men are doing in engineering, design and construction in order to make better flying machines. Why the United States has the best airplanes in the world.

### THE OFFICIAL JUNIOR ANNUAL

Compiled and Published by

### The AERONAUTICAL CHAMBER of COMMERCE OF AMERICA, Inc.

Publishers of The Aircraft Year Book for 17 Years  
30FA Rockefeller Plaza New York

### MAIL COUPON TODAY

AERONAUTICAL CHAMBER OF COMMERCE OF  
AMERICA, INC., Dept. FA.  
30 Rockefeller Plaza, New York

Kindly Mail (postage paid) THE JUNIOR AIR-  
CRAFT YEAR BOOK FOR 1935 for which I enclose  
money order } for \$1.50.  
or check }

Name .....  
PRINT OR TYPE

P. O. Address .....  
NUMBER STREET

.....  
CITY STATE

taken at least two weeks to accomplish by manpower up the steep trails.

Score two for the Army's help in troublesome emergencies!

At about the same time that Master Sergeant Davis was planning his house-dropping expedition over Koolau in Hawaii, the Philippine Government was planning a careful survey of a difficult stretch of territory on one of the most remote islands of the Philippine Archipelago. This particular territory had never before been covered by surveyors and many difficulties were expected. The Army was consulted for help in easing these difficulties, with the result that two photographic crates from Nichols Field, at Rizal on the island of Luzon (six miles from Manila), were ordered out to assist in the survey.

These picture ships flew over and took a series of vertical pictures of the two rivers flowing through the ground that was to be charted. Pasted together in strips, the prints made excellent pictographic maps for the use of the Air Corps ground party that went out a few days later. The photo ships also made pictures of the mountain ranges which, when plotted out carefully upon a rough map, were of great value in making an accurate topographic map of the entire area.

Also of value in this non-military expedition was the work of planes in supplying the ground groups with provisions, medicines and other supplies, for in view of the fact that ground travel was done through virgin jungle, the carrying of enough supplies for comfort was absolutely out of the question.

The Army flyers have been called on many occasions for mapping and similar photographic work, and this instance of work in the Philippines is not unusual. At one time, from the 15th Photo Section at Crissy Field, California, an officer pilot and an enlisted photographer shot and mapped several hundred square miles of country along the Snake River in Idaho and Wyoming, and in the Falls River Basin of Yellowstone National Park. From an altitude of ten thousand feet, this work was performed with a single lens K-3 camera, for use in thorough stereoscopic study and topographic surveys of the section. The work was made by the Bureau of Reclamation in the Department of the Interior. Even Uncle Sam's own departments, it can be seen, call upon the Army flyers when confronted by difficulties.

**A**RMAY airplanes have long been used by military and civil officials in peacetime wars against insect pests of various kinds. In Panama, mosquito warfare is now a routine job for most Army flyers, who take turns in hedge-hopping across the tropical swamps which, if not frequently sprayed with Paris Green or oil formulas, breed millions of infective mosquitoes and other insects.

In the cotton district of the South, planters often call upon the Government for help against the boll weevil that preys upon their cotton crops. In such cases, Uncle Sam frequently assigns an airplane from the nearest Army field to go out and spray the crops with chemical compounds—a job that can be done only from the air.

Every few days, the nation's newspapers carry stories telling how, in some out-of-the-way section of the country, a flying ambulance piloted by Army men has proved the only means of getting a seriously ill patient to a hospital in the city many miles away. Result, an emergency operation has been performed and, in most cases, the life of the patient has been saved. This mission is now becoming so common that the newspapers seldom treat it as first page news any more.

Most of you will remember how in March, 1929, thousands of acres of land bordering the Mississippi were inundated when the river's heavy waters broke through the dikes. Scores of people were drowned, hundreds injured and thousands rendered homeless. The only way to reach some of the flooded sections was by air, for there were not half enough boats to accomplish the necessary relief work of the Red Cross and similar agencies. Hence the Air Corps was appealed to and, as is always the case in a worthy cause, the appeal was not in vain.

Officers and men of the Corps, with civilian helpers, labored day and night in the preparation and packing of food-stuffs, clothing and medicines. At Maxwell Field, Alabama, the Army force was greatly increased, and before the flood had receded, the flying field resembled an Army base in wartime. From Maxwell Field, most of the actual aerial relief was performed, and even outboard motors were hung onto bomb shackles for dropping where they were needed.

Always these Army airmen are ready and waiting to be called on—in times of peace as well as war.

## Wings AWeigh!

(Continued from page 9)

second, a white light; the third, a blue light; and so on. These lights are mounted on the top of the fuselage, and the other pilots in the formation follow the color of the section to which they are assigned.

To bring a high-speed fighting plane down safely on a pitching and tossing

platform, which is obscured to the pilot's view at the moment of contact, is a job that requires the utmost in training and skill. Let's imagine ourselves in the pilot's place and climb into the cockpit of one of these fighters and see how the trick is done.

A cold wind is blowing from the east,

and we shiver a little, in spite of our fur-lined clothing. Slowly we taxi forward into position. Two sailors, dwarfed by the size of the plane, tug at each wing tip as they help steer us out. Then the deck officer gives the signal to take off, and we pour the soup to the engine. The plane leaps forward, and long before we reach the end of the deck, we are clear and climbing steeply.

Flying over the sea in moonlight is an experience of incredible beauty, but tonight is overcast and inky black. Navigation is difficult, and we hope we will be able to find our way back. The carrier is steaming steadily forward and when we return, she may be one or two hundred miles from where we left her. However, we carefully plotted our course before we shoved off, so, barring accidents, we should be able to intercept the course of the carrier when we have completed our mission.

When the big moment of going home to roost does arrive, we are reassured by a faint blur of lights far below, their reflection bobbing on the waves. As we come closer, we can make out the row of lights which outline the landing deck. The engine is throttled, and we glide down, the wind singing shrilly on the strut wires.

Soon we can pick out two lights near the bow which will guide us in to a landing. These lights are electric wands, not unlike an orchestra leader's batons, which replace the landing officer's flags used during daylight operations. As we come over the deck, our lower wing obliterates the string of lights around the landing platform, and we see nothing but the two lights held in the hands of the signalman.

It is a tense moment. The slightest miscalculation on the part of the officer on deck or on our own part will result disastrously. If the approach has been properly made, one wand will be seen to move horizontally from right to left and the other drops downward. It is time to kill the engine and ease back on the stick for contact with the deck.

The slight jolt and rumble of our landing gear are welcome signs that the landing has been well done.

Before a pilot attempts to make landings on a carrier deck, he first practices landing on a "deck" outlined on a flying field ashore. These landings are made both in daylight and in darkness. Landing officers also practice guiding pilots down on this shore "deck" until they become thoroughly proficient.

When each thousandth landing has been made on a carrier, the pilot is presented with a large layer cake. This is a very formal ceremony and is attended by high-ranking officers.

When airplanes are operating out of sight of the carrier, forced landings in the water are one of the greatest hazards that the pilot has to face. All planes are equipped with flotation gear to keep them on the surface. In addition, a rubber air raft for the pilot is carried in case the plane should sink in spite of its water wings. These devices are inflated from flasks of carbon dioxide gas, and the process takes but a few seconds.

WHEN a plane is forced down out of formation, a ship is radioed to come to the rescue, and another plane usually remains and circles over it to enable the ship to locate it more easily. The cooperation and courage that Navy flyers display when a brother pilot is in distress was demonstrated during recent maneuvers off the Pacific Coast.

Theodore Gay, an Aviation Metal-smith Mate, was riding in the front cockpit of a big torpedo plane. They were far out at sea. The waves, thousands of feet below, were flattened into diminutive ripples. As Gay's eyes scanned the distant horizon, he noticed a group of fighting planes milling about. Suddenly one of them detached itself from the rest and headed down. Looking more closely, Gay noticed that the propeller was barely turning over.

Forced landing! Gay watched the little ship sink lower and lower towards the turbulent water. Just before it struck, its young pilot, Ensign Allan Dunning, leveled off and tried to make a safe landing. There was too heavy a sea running, however, and the plane nosed into a mountain of water which hurled it over on its back.

In a few seconds, Gay saw a head bob to the surface. Dunning had extricated himself from the submerged cockpit and was gamely fighting for his life. Gay could see him swimming about in the water.

One of the other fighting planes in the formation immediately began circling low over the imperiled airman. The pilot of the fighter was trying to get his rubber boat inflated so that he could drop it to Dunning. This, he found, was impossible to do.

The torpedo plane then proceeded to the rescue. It could be clearly seen that the man struggling in the water would not be able to hold out much longer. While tricky air currents buffeted the big ship about roughly, Gay climbed out of the front cockpit, slid along the fuselage to the tool compartment abaft the main cockpit, and got out the rubber boat. Holding himself to his precarious perch with one hand, he managed to get the boat inflated. Then, as the ship swept low over Dunning, Gay dropped the boat over the side.

Dunning immediately swam to it and pulled himself aboard. A destroyer had been radioed, and soon appeared on the scene to rescue the flyer. Gay's courage-

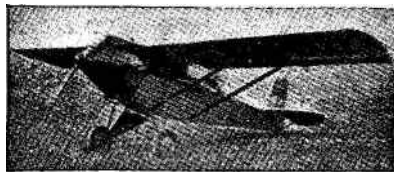

**36-INCH CORBEN SUPER-AGE**  
**36-INCH FOKKER D-VII**  
**36-INCH CURTISS GOSHAWK** **1.00 EACH**  
**P.P.**  
 BOYS! The biggest bargain in kits on the market. You'll say so, too, when you see these new models. Complete—nothing else to buy. Best quality materials and plenty of them. Plenty of dope, cement, AA Jap tissue, Grade A Balsa, printed rib sheets, printed formers, wire parts formed, finished propeller, real scale full size 36" wingspan plans, etc.

- Free offer not included with these kits.
- 18 IN. LENGTHS**  
 1/16x1/16.....35 for 5c  
 1/16x1/8.....20 for 5c  
 1/8 x1/8.....16 for 5c  
 1/8 x1/4.....8 for 5c  
 1/4 x1/4.....5 for 5c  
 1/2 x1/2.....2 for 5c
- 18 IN. SHEETS**  
 1/32 and 1/16x2 6 for 10c  
 1/8x2.....4 for 10c  
 1/4x2.....3 for 12c
- 18 IN. PLANKS**  
 1x1 1 for 7c 2x2 1 for 20c  
 1x2 1 for 11c 2x3 1 for 25c
- JAPANESE TISSUE**  
 1 doz., all colors, AA.....19c
- SILVER TISSUE**  
 20" x 24".....each .05
- SUPER-FINE TISSUE**  
 White Only  
 Sheet.....5c; dozen.....50c
- BALSA WHEELS**  
 1 1/2".....5c 3/4".....7c  
 1".....5c 1 3/4".....4c  
 2".....10c 3".....17c
- DOWELS**  
 1/16x6.....doz. 5c  
 1/8x18.....2 for 5c
- WIRE**  
 2 ft. 1c  
**INSIGNIA SHEETS**  
 24 and strips.....5c
- WASHERS**  
 1 doz. 3/4 or 1/2.....1c
- PROPELLER BLOCKS**  
 1/2 x 3/4 x 6.....6 for 25c  
 3/4 x 1 x 7.....3 for 5c  
 3/4 x 1 x 8.....3 for 5c  
 1 x 1 1/2 x 12.....1 for 4c  
 1 x 1 1/2 x 12.....1 for 7c
- MORE PINS**  
 1 doz. 5c
- THINNERS**  
 1 oz. 2 ft. 1c
- REED**  
 1 doz. 5c
- BUSHINGS**  
 1 doz. 5c
- SANDPAPER**  
 pkg. .5c
- PROP. SHAFTS**  
 doz. 8c
- NOSE PLUGS**  
 doz. 10c
- BIRCH WHEELS**  
 1 1/2".....2c 3/4".....3c  
 1".....4c 1 3/4".....5c  
 2".....10c
- SHEET ALUMINUM**  
 .005 in. thick, 15c sq. ft.  
 .010 in. thick, 20c sq. ft.
- CLEAR DOPE**  
 1 oz., 5c; 1/2 pt., 30c
- COLOR DOPE**  
 1 oz. bot., all colors, 5c

**FREE**  
 With every order of \$1.00 or over post-paid—  
 2 oz. bottle CLEAR CEMENT and 100 1/16x1/16x18 BALSA STRIPS

- CLEAR CEMENT**  
 1 oz. bot. ....5c  
 2 oz. bot. ....10c  
 1/2 pt. bot. ....35c
- MACHINE-CUT PROPS**  
 5".....5c 6".....6c  
 7".....7c 8".....8c  
 10".....10c 12".....12c
- BAMBOO**  
 1/16x1/16x12 .36 for 5c  
 1/16x1/4x15 ea. 1c; doz. 10c
- THRUST BEARINGS**  
 Small.....doz. 10c  
 Large.....doz. 15c
- RUBBER**  
 1/16x1/16.....18 ft. 5c  
 1/8 flat.....15 ft. 5c
- WOOD VENEER**  
 20x30.....1 for 10c
- SHEET CELLULOID**  
 Cx8.....5c 12 1/2x16.....20c
- CELLULOID WHEELS**  
 3/4".....5c 1 3/4".....pr. 10c  
 1".....pr. 7c 1 1/2".....pr. 17c
- DUMMY RADIAL ENGINE**  
 1 1/2" dia. 18; 2" dia. 23; 3" dia. 33  
**ENGINE AND COWL ATTACHED**  
 1 1/2" dia. 20; 3" dia. 35  
**CELLULOID PARTS**  
 1/2" to 1 1/2".....pair 18  
 1 3/4" to 1 7/8".....pair 33
- ALUMINUM COWLINGS**  
 1 1/2" 15; 2" 18; 3" 25  
 Specify whether anti-drag, closed, or open.
- BOMBS**  
 3/4" 04; 1 1/4" 07; 3" 12
- GUNS WITH RING MOUNT**  
 1 1/2".....10; 1 3/4".....15
- PURSUIT MACHINE GUNS**  
 3/4", 1 1/4", or 1 3/4" ea. 05
- PROPELLERS**  
 2 blades 3 blades  
 1 1/2".....08  
 2 1/2".....12  
 3 1/2".....18  
 4 1/2".....20  
 5 1/2".....20
- WING AND TAIL LIGHTS**  
 1 1/2".....10c  
 1 3/4".....15c  
 2 1/2".....20c

20 IN. FLYING PLANS 10c-3 for 25c  
 Texas Sky Chief, Sparrow Hawk, Boeing Trans. 247,  
 Spad Cabin, Vought Corsair, Curtiss Swift L. W.,  
 Waco Cabin Biplane, Douglas Dolphin, Boeing P12F,  
 Fokker D-VII, S.E.5, Goshawk, Gee Bee.  
 Dealers, Clubs, Schools: Write for Wholesale Price List.

**IMPERIAL MODEL AERO SUPPLY**  
 Kensington Sta.,  
 416 McDonald Ave., Dept. B, Brooklyn, N. Y.



Learn How to Operate a Plane In Your Own Home with this thrilling **TRAINING PLANE**

**An Amazing New Invention! Not a Toy!**  
 A practical training plane developed at the Casey Jones School of Aeronautics, Newark, N. J. Indorsed by such famous pilots as Casey Jones, Amelia Earhart, Lieutenant-Colonel Vaughn, Lee Warrender and many others. Learn how to take off, climb, dive, bank, turn; how to avoid side-slips, stalls, tailspins, and other dangers; teaches you all about flying — and works just like a real airplane. Go through the actual maneuvers of the aces. Comes complete, all ready to assemble. Simple directions with every set. Anyone can set it up in a very short time. Actually promotes knowledge of aviation.

**\$1**  
 At Your Dealer \$1.10 by mail \$1.25 W. of Mississippi.  
 \$1.60 Foreign  
 Clip this adv. and mail with remittance.

Training Plane Dept., Heaney Laboratory, Glenn Curtis Airport, Jackson Heights, L. I.

**BUILD** These Beautiful Super-Detail Guaranteed Flying Planes—All in Exact Scale with Cockpit Operated Controls. Designed for you by flying men.

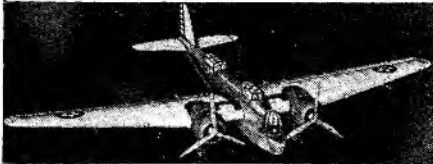

MARTIN BOMBER

Wingspan 35", length 22½", weight 4½ oz. Exact scale. Retractable landing gear, rotating gun turret, movable machine guns, special streamline cowling, two types of 3 bladed propellers—one for flying and one for exhibition with removable motor sticks for flying; rudder and elevator balanced surfaces; new type freeze ailerons. **\$3.50**  
Kit complete, postpaid

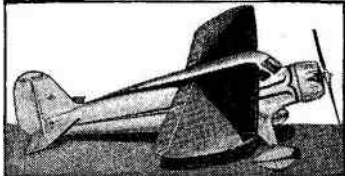

STINSON RELIANT

Wingspan 32 5/16", length 21¼", weight 3½ ozs., exact ¼" scale. Adjustable speed arresters built into the wings, movable cabin doors, complete interior with four seats and control column, and all the other Super-Detail features. **\$2.50**  
Kit complete, postpaid

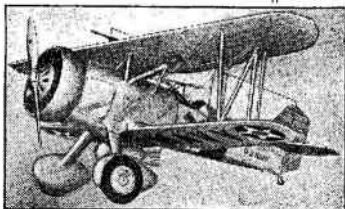

CURTISS GOSHAWK

Wingspan 23 3/8", length 16¾", weight 3½ oz., exact ¼" scale. Coated with new IDEAL high lustrous finish, with silver, yellow, red and black coloring. **\$2.00**  
Kit complete, postpaid

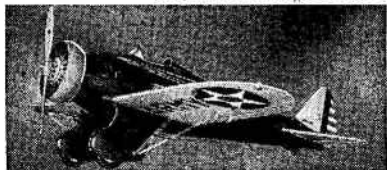

BOEING P-26A

Wingspan 21¼", length 18", weight 2½ oz. Exact scale. This flying model is an exact replica of the famous fighter—one that is identical in all but size with its noteworthy big brother. Beautifully colored in olive drab and yellow. **\$1.75**  
Kit complete, postpaid

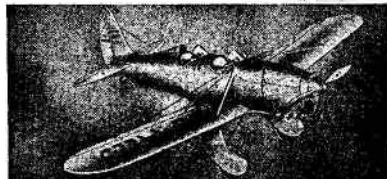

RYAN S T

Wingspan 22½", length 16½", weight 2½ oz. Exact scale ¼". Ryan has dual control system which operates in either cockpit; adjustable wing flaps, plans for making an actual working engine—4 cylinders with movable pistons, carburetor and spark plugs. Complete kit, postpaid... **\$1.50**  
IDEAL—The most reliable name in model airplanes

**ILLUSTRATED FOLDER**—Send 3c for the new latest model IDEAL folder showing the information on how you can make real money by building and selling these famous flying models.

**IDEAL AEROPLANE & SUPPLY CO., Inc.**  
21 West 18th St. New York City  
Pacific Branch { MODEL BOAT & AIRCRAFT CO.  
1356 5 Ave., San Diego, Calif.

See your local dealer or send this coupon

IDEAL AEROPLANE & SUPPLY CO., INC.  
21 W. 18th St., New York City.  
Please send the items I have checked. I am enclosing 3c (West of Denver 25c extra. All orders postpaid.) Canadian Prices 40% higher to cover duty.  
Boeing P-26A  \$1.75 Stinson Reliant Airliner  \$2.50  
Martin Bomber  \$3.50 Curtiss Goshawk  \$2.00  
Ryan S T  \$1.50 Folder with information  3c

Please print name .....  
Address .....  
City ..... State .....

ous action saved the officer's life and he was commended by the Secretary of the Navy.

Sometimes help is not so near when a sea-going airman gets into trouble. Chief Aviation Pilot Verne Harshman drifted about for five days, tossed by tropical storms and scorched by a blistering sun, before he was finally picked up.

Harshman was piloting a fighter over the Pacific Ocean off Panama. The choppy blue water stretched away in all directions to meet the sky on an unbroken horizon. The carrier had long since faded from view. Suddenly the engine began to sputter. Harshman tried desperately to keep it running, but in spite of his efforts, it coughed a few times and then conked cold. The rough sea rushed swiftly towards him.

Harshman pulled his nose up and skimmed over the waves at express-train speed. Then, as his ship began to

settle, he pancaked. He struck hard and careened into a trough. The machine was badly smashed up and rapidly sank. Harshman inflated his rubber boat, and barely had time to get into it and shove himself clear when his plane departed for Davy Jones' locker.

Then began an experience as harrowing as a man ever lived through. Vicious storms tossed the boat about as if it had been a chip. The intense heat of the tropical sun melted the rubber and caused leaks, which Harshman patched in a makeshift manner. Sharks and porpoises attacked the boat and the luckless flyer fought them off as best he could. Finally, when his life had been despaired of, a steamer chanced to pass near him and picked him up.

Usually help comes sooner, however, for the Navy is always quick to rescue its sea-going airmen, those daring pilots who form one great bulwark of our nation's defense.

## Build the Martin Diving Bomber

(Continued from page 28)

Now trace out the views of both cockpits onto the shell and, with a thin knife blade, puncture the center and cut away carefully, close enough to the outlines to allow the finishing to be done with sandpaper.

The nose plug is made in two parts. The front part is rounded, and the rear is a square piece. Use soft balsa. Before cementing the rear part to the nose piece, cut away a portion in the center of the top of the square piece to place the motor stick. Apply cement and slip in the motor stick. Add the rear wire hook. Place a small eyelet bearing in the center of the nose piece and push a needle all the way through for the propeller shaft hole.

### WINGS AND TAIL SURFACES

**T**HE upper and lower right wings are shown full size. The length of the spars may be measured direct from the plan. Build the wings in the same careful manner as you have always done. Use 1-16" square bamboo for the wing tips. Make the bottom and top left wings simply by retracing both parts given on the plan and turning them over. The center-section is made like the wing, except for the trailing edge, which is shaped from 1-16" square bamboo. Cover each part of the wing first. Use banana oil for the adhesive. Pull paper tightly and remove all the wrinkles possible.

Never attempt to cover the upper surface of the wing all in one piece. Apply the Jap tissue as far as the last rib at the wing rip. From there on, use a separate piece between the last rib and the rounded edge.

With an ordinary household atomizer, spray the three parts on both sides with water and set them up against a wall to dry. We suggest that covering the upper surface of the top wing with a

piece of yellow tissue and then adding a regulation star at each tip will help the model's realistic appearance and at the same time avoid the weight of yellow dope.

The undersides of the top wings are covered with white tissue. Add stars at the tips of the undersides of the lower wings. Now cement the right and left upper wing to the center-section, at the same time raising each tip end to a ½" dihedral angle. The wing, you'll notice, has the sweep-back angle, also.

The outlines of the rudder and elevators are cut from 1-16" thickness sheet balsa and are ½" wide. Watch your grain when cutting out these parts. The elevator is made in halves. The ribs in both elevator and rudder are 1-16" square balsa, cut to sizes measured direct from the plan. The spars in the rudder and elevator are cut from 1-16" sheet. Notice how they taper down at one end, as shown. Cover the surfaces on both sides and spray with water—but very lightly. Place a book over them to prevent warping.

### LANDING GEAR

**T**HE measurements of the landing gear struts are taken from the drawing. Use hard balsa wood here, and streamline each strut carefully. Attach the fuselage as shown in Plan No. 1 and Plan No. 5. A looped wire at each side provides for the shock absorbers. Balsa or celluloid wheels, 1 5-16" diameter, may be used.

If you can obtain a small, nine-cylinder, celluloid dummy motor to fit your model, well and good. Cut off the cylinders and cement around nose in the positions marked as shown on Plan No. 5. If you are unable to procure this dummy, construct a set of nine from scrap wood, paint black and mount with



small pins and cement.

The ring cowl can be bought, or one can be carved from soft balsa. Apply cement over the tops of the cylinder heads and slip the cowl right over.

The fillet pieces are carved from soft wood to the shape shown on Plan No. 4. Two are needed. Apply cement liberally to the insides of each piece and press firmly to each side of the fuselage. Check here for alignment. See position in front view on Plan No. 5. When they have dried, cement the lower wings in place, checking on incidence and dihedral figures given in the plans. In the meantime, carve the prop to the design shown on Plan No. 4. Cement the wire propeller shaft in proper place.

Cut all the strips for the wing and center-section struts to proper size measurements taken direct from the plans. Streamline each one carefully. It is not advisable to streamline a large strip, as there is always that tendency to crack.

ASSEMBLING THE MODEL

ATTACH the tail surfaces and make sure the rudder is in line and the elevators do not droop. Mount the top wing onto the center-section struts first, and after they have dried thoroughly, cement a set of "N" struts in place as shown in Plan No. 5. Check here again for gap, incidence angle and

sweep-back. Make adjustments now before cement dries. Use small model, making pins to help hold parts in place. Later remove them.

A solid bomb may be carved from a scrap balsa block and painted aluminum. Attach bomb underneath the fuselage by small pieces of wood and cement. Make the tail wheel from balsa wood. The arresting hook shown just ahead of the tail wheel is made from a strip of balsa and curved piece of piano wire. Cement underneath the fuselage in position shown on Plan No. 2.

Two strips of balsa cut to proper size are used for the elevator brace struts. Use black thread for wing rigging. Twin dummy machine guns, touched up with aluminum and black paint, may be attached to a rotating gun mount. Add celluloid windshields to both cockpits.

For the motor power, use four loops of 1/8" flat rubber. Apply glycerine over the rubber well. Tighten up on the "S" hook and bend the prop shaft hook closer. If possible, use a gear winder to wind up the rubber, and stretch out at least once its normal length to get more power.

Glide the model as many times as needed to bring out any tricky characteristics. By warping the rudder or elevators a little, these faults will be overcome. As usual, head your model into the wind.

Flying Aces Stamp Tales

(Continued from page 63)

On the other hand, the Austrian stamp featured a night bomber. Here was a nocturnal bird of prey which laid egg-bombs from the skies. Yet it was pictured on a charity stamp that sold for 38 heller—35 heller going for postage, and the balance of 3 heller being devoted to helping war orphans. Stamps symbolic of such tragedies are not so common.

Air mail stamps have their humorous side, as well, however. From Austria it is only a "barnstorming" tour to Italy, and entirely surrounded by Italy is the Republic of San Marino, the smallest sovereign state in the world. This nation of 38 square miles has, strangely enough, issued some of the largest stamps. Moreover, it is perched on the Apennines—balanced, we might almost say—so that a helicopter or autogyro would be needed, to make a ten-cent-piece landing in such a perpendicular country.

Dr. Bruno Roselli, returning from a visit in 1932, quoted the genial San Marino postmaster as saying, "If we sell enough air mail stamps, we may begin to plan our own aviation." Well, Lilliputian San Marino, with Brobdignagian commemorative stamps, issued ten air mail stamps which ranged in face value from 6c to \$1.20; and, during 1933, in honor of the Zep, it surcharged six of those stamps with higher values

and a view of the big gas bag. These revised values sold initially for 40c to \$2.40. Complete sets of San Marino's air mail stamps sell for \$4.25 and \$7.50, so perhaps the 13,948 citizens of the air mail-less country are beginning to plan a side-hill hangar for a plane or two.

Newfoundland honored Alcock and Brown in 1928 with a 15c dark-blue stamp picturing that famous first transatlantic plane—a Vickers-Vimy bomber with 800-h.p. Rolls Royce motors. You can't see the power plant, but the ship is illustrated as just about to bank for a turn. Strictly speaking, this is not an air mail stamp, but it belongs in every historical aviation stamp collection. The stamp was about nine years late in appearance, for Captain John and Lieutenant Arthur captured that \$50,000 prize in June, 1919.

Australia, in 1929, raced to do honor to Kingsford-Smith's world flights. A beautiful gray-violet 6-pence stamp (now worth more than a quarter) depicts Kingsford-Smith's old reliable monoplane soaring above the two hemispheres. We understand that this ship was one of Tony Fokker's pet jobs.

Next, we will take our observation plane over the negro republic of Haiti. Just one year later than her rival, the Dominican Republic, Haiti issued a quarter of a million air mail stamps in

**HANDEE**  
Tool of 1001 Uses

Grinds, routs, drills, carves, sharpens, cuts, engraves. Over 100 wheel shapes available. Fits the hand perfectly. Weighs 1 pound. For use at home, in the shop or take to the job. Do away with slow hand work! A. C. or D. C., 110 volt, 13,000 r. p. m.

Order on 6-day trial. Satisfaction guaranteed. Ask for FREE booklet.

**\$10.00** and up Postpaid U. S. A. with 3 wheel shapes Free. Order today.

**New MASTER CRAFTSMAN'S SET** 17 useful accessories to grind, drill, polish, sand, cut, carve, engrave, etc. Prepaid \$5.00

CHICAGO WHEEL & MFG. CO., 112 S. Aberdeen Street, Chicago, Ill.

**MECHANICAL ENGINEERING**

**LEARN AT HOME**

MECHANICAL Engineering embraces the design, construction and operation of machines and machine tools. It is a profession which offers almost unlimited opportunities to men who combine natural mechanical ability with technical training.

For this is The Age of Machinery. Almost every convenience, luxury or necessity which we enjoy depends on machinery for its production or adaptability to our needs. Every new invention multiplies the opportunities for competent designers, builders, erecting engineers, etc.

One of the best ways to train yourself to secure a position as a Mechanical Engineer is through the home-study courses of the International Correspondence Schools. They are particularly helpful because they are written by well-known mechanical engineers with years of practical experience, who know the best way to solve every problem. Just mark and mail the coupon and we'll gladly send you Free Booklets describing the I. C. S. courses in Mechanical Engineering or any other course in which you are interested.

INTERNATIONAL CORRESPONDENCE SCHOOLS

Box 4159-B, Scranton, Penna.

Without cost or obligation, send your booklet, "Who Wins and Why," and full particulars about the course before which I have marked X:

- Mechanical Engineering
- Mechanical Course
- Drafting
- Mechanical Drawing
- Complete Shop Practice
- Architect
- Architectural Draftsman
- Building Foreman
- Concrete Builder
- Contractor and Builder
- Structural Draftsman
- Structural Engineer
- Electrical Engineer
- Electrical Contractor
- Electric Wiring
- Electric Lighting
- Electric Car Running
- Telegraph Engineer
- Telephone Work
- Civil Engineer
- Surveying and Mapping
- Bridge Engineer
- Gas Engine Operating
- Automobile Work
- Aviation Engines
- Toolmaking
- Blacksmithing and Forging
- Patternmaking
- Foundrywork
- Machine Shop Practice
- Plumber and Steam Fitter
- Plumbing Inspector
- Foreman Plumber
- Heating and Ventilation
- Sheet-Metal Worker
- Steam Engineer
- Marine Engineer
- Refrigeration Engineer
- R. R. Positions
- Highway Engineer
- Chemistry
- Pharmacy
- Mining Engineer
- Navigation
- Assayer
- Iron and Steel Worker
- Textile Overseer or Supt.
- Cotton Manufacturing
- Woolen Manufacturing
- Agriculture
- Fruit Growing
- Poultry Farming
- Mathematics
- Radio

BUSINESS TRAINING COURSES

- Business Management
- Industrial Management
- Personnel Management
- Traffic Management
- Accounting and C. P. A. Coaching
- Cost Accounting
- Bookkeeping
- Spanish
- French
- Salesmanship
- Advertising
- Business Correspondence
- Show Card and Sign Lettering
- Stenography and Typing
- English
- Civil Service
- Railway Mail Clerk
- Grade School Subjects
- High School Subjects
- Cartooning
- Illustrating

Name.....

Address.....

City.....State.....

Occupation.....

If you reside in Canada, send this coupon to the International Correspondence Schools Canadian, Limited, Montreal, Canada.

**BUYERS' DIRECTORY**

Airplanes and Accessories, Schools—  
Flying Instruction  
\$5 per inch— Payable in Advance

**AIRPLANE SUPPLIES**

Join Karl Ort's Satisfied Customers by sending me "Two Bits" (25c) today for my new 1935 Aviation Supply Catalogue and I'll give you one of these beautiful Pilot's Lapel Pins absolutely free of charge while they last. You win twice because the pin alone is worth 25c, and the catalogue will save you many, many dollars on your Aeronautical purchases. KARL ORT, 630 W. POPLAR ST., York, Penna.

**NEW AEROPLANES, Less Motor, \$98.00**

Powered with Ford Motor, \$148.00 each. New production, beautiful mid-wing design, complete with 7.00-4 air wheels. We are booking orders now. Send 50c for leather-bound flying manual and more information about this sensational aeroplane.

**UNIVERSAL AIRCRAFT CO.**  
Dept. 6 Fort Worth, Texas

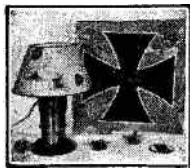

*Authentic Imported*  
**A. E. F.**

**World War 1914-1918**  
**Aviation Souvenirs**

A colored folder listing some as low as six cents postpaid; sent upon receipt three cent stamp.

**Northrop Aeroplane Co.** Minneapolis, Minnesota

**AERONAUTICAL FRATERNITY**

**AVIATION**  
**APPRENTICES**  
AIR-MINDED Young Men interested in entering the field of Aviation as Apprentices Write immediately, enclosing stamp, to **MECHANIX-UNIVERSAL AVIATION SERVICE**  
P. O. Box 33 [Dept. J] Detroit, Mich.

**CLASSIFIED DIRECTORY**

Use this Directory for prompt response. Rate: 10c per word (minimum 20 words.) CASH WITH ORDER. September ads. must be in by July 1. Make remittances payable to:

**HARRY SAUNDERS**

Classified Ad. Manager, 230 West 41st St., New York.

**MODELS—MATERIALS—EQUIPMENT**

**JAPANESE Model Airplane Tissue**, 32 colors, also Wood Veneer. Ask your dealer for Whitfield's paper—it's the best. Send for samples. Whitfield Paper Works, Inc., 18 Vestry Street, New York City.

**BALSA Odds and Ends**, Big "Workshop Bag," 18" Strips, Sheets, blocks, 10c and 3c postage each. Also "Suwanee River Special" bag, 20c postpaid. Tropical Wood Importers, 8637, Tampa, Florida.

**GAS Model and Model Supplies**. Free price list. Discount to Dealers and Clubs. Newark Model Airplane Co., 51 Jacob St., Newark, N. J.

**LOWER prices than advertised**. Post card brings free price list containing big free offer. Whirlwind Model Airplane Co., 124-17 Hillside Ave., Richmond Hill, L. I.

**SONG PUBLISHERS**

**WANTED:** Original Poems, Songs for immediate consideration. MMM Publishers, Dept. F.A., Studio Bldg., Portland, Ore.

**PATENTS**

**PATENTS Secured**. Low cost. Reasonable terms. Book and advice free. L. F. Randolph, Registered Patent Attorney, Dept. 572, Washington, D. C.

**FOR SALE**

**\$7800 RECORDING Barometers**, slightly shop worn, records to 20,000 feet. Special \$17.50 ea. Fiala Outfits, Inc., 47 Warren St., New York City.

**LOWEST PRICED Gasoline Motors for**

Boat and Airplane Models, 1 and 2 Cylinder Motors. Send 10c in Coin for information and sectional view drawing of 1 cyl. motor.

**POWER MODEL BOAT & AIRPLANE CO.**  
134 So. Clinton Street  
Chicago, Ill. Dept. A-8

**DEALERS NOTICE**

**6" wing span ALL-BALSA STUNT GLIDERS**

These gliders are scientifically designed to fly, loop the loop, zoom, bank and turn, and for straight flights. Wonderful outdoor or indoor flyers. Lots of fun for Everybody.

**4 (four) for 10 cents P. P.**

**DEALERS**, cash in on the profits. They go over big. \$1.65 per gross, P.P. Satisfaction guaranteed.

**MIDGET AERO SHOP**, Dept. 2, 3747 E. 95 St., Cleveland, Ohio.

four denominations, brightly colored green, dark violet, red violet and blue. The central theme of these stamps was a giant Ford trimotored cabin plane, winging its way over the capital of Port-au-Prince.

Ecuador illustrates what looks like a commercial Bellanca model. France, in 1934, commemorates that epochal cross-channel flight of Louis Bleriot in his monoplane 25 years before. This latter stamp shows a quartering tail view of the old bus, superimposed upon a chart of the Calais-to-Dover course. These are just a few of the hundred of different views of typical heavier-than-air machines that can be discovered upon postage stamps.

Here's a tip to Flying Aces stamp fans—don't just mount your air mail or aviation subject stamps in *echelon*

in your album. Instead, hinge only a few on a single page. Leave lots of room around each stamp for the printing or pasting of data. Perhaps, on the facing page you will want to show other views—photos—of the same ship. As to the data, add the model number, registration insignia, nationality symbols, the designer of the craft, make of power plant, its rating, landing speed, wing spread and any other technical information that you are able to dig up. Such a collection represents *your* work and knowledge. It will be of interest not only to fellow collectors but to all aviation enthusiasts. Clippings and illustrations from **FLYING ACES Magazine** will further dress up your album.

Next month, we will hop off to some more foreign lands in search of stamps that are odd or contain errors.

**Aerodynamics Simplified**

(Continued from page 35)

to as the "Great Inversion."

It was found by Charles, a Frenchman, in 1787, that the volume of any perfect gas varies directly with the applied absolute temperature, under a constant pressure. That is to say, when the temperature of a volume of gas is increased, the volume likewise increases.

This may be expressed as follows:

$$\frac{V_1}{V_2} = \frac{T_1}{T_2}$$

The term, "perfect gas," as referred to in both Boyle's and Charles' Law, is a gas in which each molecule is a separate and distinct particle, free from combination due to changes in pressure and temperature. Unfortunately, there is no such gas known.

The most ideal gases are oxygen, helium, hydrogen, and air. It is interesting to note that if air were a perfect gas, all objects, regardless of shape or size, would move through the atmosphere with perfect streamline. Though air is not a perfect gas, the results obtained from Boyle's and Charles' Law give us a fairly accurate answer.

Absolute zero is the point at which all heat is said to disappear. Such condition is believed by scientists to exist in stellar space. Lord Kelvin, through experimenting, determined this point on the Fahrenheit scale, and found it to be 459.4° below zero. Though no such condition has ever been reached on the earth, scientists in Germany have succeeded in approaching it quite closely. In the application of Charles' Law, all temperatures must be changed to their absolute value.

To change a Fahrenheit temperature to its absolute value, you must add it to absolute zero, or 459.4° F.—such that the absolute value of standard temperature would be 459.4° plus 59°, which is equal to 518.4° absolute. If we have a minus temperature, such as -59° Fahrenheit, we subtract the temperature as follows: 459.4°-59°, which is

equal to 400.4° absolute.

Suppose that at 30° Fahrenheit ( $T_1$ ), a certain gas has a volume ( $V_1$ ) of 10 cubic inches. If the temperature ( $T_2$ ) is increased to 60° Fahrenheit, the new volume ( $V_2$ ) may be found as follows:

Substituting in our formula and changing all our temperatures to their absolute value (assume absolute zero to equal 460°):

$$\frac{10}{x} = \frac{460 + 30}{460 + 60}$$

$$490x = 5200$$

$$x = 10.73 \text{ cubic inches}$$

A cubic foot of lead weighs more than a cubic foot of wood, so we say that the lead has a greater density than the wood. Density, as defined by physics, is the weight per unit volume, and is generally measured in pounds per cubic foot. The density of air, as our definition follows, would be .07651 pounds per cubic foot.

In aeronautics, we consider density as specific weight, which is defined by the N.A.C.A. as weight per unit volume, measured in pounds per cubic foot. Thus, the specific weight of air is .07651 pounds per cubic foot.

Density, as defined by the N.A.C.A., is the mass per unit volume, measured in slugs per cubic foot. The mass of a body may be found by dividing the weight of the body by the earth's gravitational pull, which International Standards define as 32.17 feet per second per second. From this we can compute the density of the air at sea level, which is .002378 slugs per cubic foot. The term slugs is a unit of measure adopted by the N.A.C.A. for measuring mass.

Both the density and the specific weight of air decrease with altitude. The amount of decrease is shown on Figure 2 for altitudes up to 20,000 feet.

# Now you can LIVE and HUNT just the way real Indians did!



You'll get twice as much fun out of your summer camping if you know how to live outdoors *in the genuine Indian way*. But it takes a real old Indian Scout like Ernest Thompson Seton to show you. With his help you can

## MAKE a GENUINE TEPEE to Camp In!

Make *authentic* BOW and ARROWS—*real* CHIEF'S WAR BONNET—MOCCASINS—FIRE DRILL—DRUM!

Ernest Thompson Seton (who lived with Indians) will tell you how

**OLD SCOUT SETON** is one of the few men left who know from experience just how Indians made and used their weapons and camping equipment. When Seton lays out the canvas for a real Indian tepee—and helps his vacation camp crowd to cut, sew, decorate, and erect it—they know they have the genuine article!

And you'll get the real thing too—when you follow the careful scale plan for the tepee which Seton drew himself and has put into the book on INDIAN CRAFT in his set of volumes called "The Library of Pioneering and Woodcraft."

You'll find it just the same with all the other Indian implements for which Old Scout Seton gives you detailed directions. For instance, he shows you just what kinds of woods and tinder to use in

### Making Fire with a Fire-Drill

It takes skill of which you may well be proud to kindle a blaze as the Indians did—but Seton shows you how to do it easily. And he gives you definite instructions for finding natural foods—gives you pictures drawn by himself to help you to identify flowers, birds, trees, mushrooms, and animal tracks.

Out of his great practical experience in blazing trails and canoeing through wild country he tells you every detail you'll need for safety and pleasure—no matter where you go to live in the woods.

### His Books Will Make You a Daniel Boone

You'll have at your fingertips all the nature-wisdom that guided the famous early Indian Scouts through the primeval forests and deserts of the untamed West.

Seton shows you how to hunt with both gun and bow and arrow—how to use the sign language of tree blazes, tufts of grass and stones—how to erect water-proof shelters—make bough beds—build and cook with campfires—forecast weather—use the stars for your clock and compass—track animals.

NELSON DOUBLEDAY, INC., Dept. 8FA, Garden City, New York

## EXAMINE 5 DAYS FREE

NELSON DOUBLEDAY, INC., Dept. 8FA, Garden City, N. Y.

Please send me at once (for 5 DAYS' FREE READING) Ernest Thompson Seton's LIBRARY OF PIONEERING AND WOODCRAFT bound in six handsome cloth volumes (1700 pages, 1450 pictures). I will either send you \$9.85 in full payment before the EXAMINATION PERIOD is up; OR \$1.00 then and \$2.00 monthly for five months. Otherwise I will return the books in perfect condition.

Name .....

Address .....

City ..... State .....

Signature of Parent or Guardian .....

Check here if you prefer the set in ¾ leather binding for only \$14.00, \$2.00 down and \$2.00 a month for six months (or \$12.50 cash).

And all the knowledge which Seton gives you in these six fascinating books is set down from his first-hand, authentic knowledge of how the Indians and early scouts did things.

6 Volumes—1700 Pages—1450 Pictures

It'll give you a big advantage to have these books of Seton's in camp with you this very Summer—for you'll get a lot of woodcraft and Indiancraft information from them that the other fellows won't have. You can use what you learn right away. And you'll also find a lot of games to play in camp—and stories to tell around the evening fire besides.

### SEND NO MONEY

Just get your father or mother to O.K. the coupon below; then sign it with your name and address and mail it today. Send no money now. Seton's Library of Pioneering and Woodcraft will be sent to you for 5 DAYS' FREE READING. Then, after both you and your parents are satisfied that there is nothing more useful for you to have this summer (whether in camp or not) send only \$9.85 in full payment; or if you prefer to pay in convenient monthly installments you may send \$1.00, then \$2.00 monthly for five months. You'll enjoy reading them now—and you'll need them when you want to make real Indian equipment. And remember, we have only a limited number of these Seton sets left, so you better send the coupon today—and get yours for FREE EXAMINATION right now!



## You'll be eager to do all these stunts:

- Make an authentic Indian War Bonnet
- Make a tepee you can really camp in
- Stage a Bow and Arrow "Deer Hunt"
- Make a genuine Indian Drum
- Learn and perform the Caribou Dance
- Learn to use Indian "Sign Language"
- Build an Indian "Willow Bed"
- Make a pair of genuine Moccasins
- Learn to know Trees, Birds, Mushrooms
- Learn to read the "Track stories" of animals
- Make an Indian Weaving Loom
- Make and Use a real Indian Fire Drill
- Build a dam and swimming pool
- Put on authentic Indian War Paint
- Learn to mount and stuff birds
- Learn to make all kinds of knots
- Build a simple boat and dugout canoe
- Make Alaskan Indian Seats
- Make Indian War Clubs and Paddles
- and hundreds of other camping stunts.

While they last - - only  
**\$9.85**

Send No Money



# NOW

# ...a GENUINE DAISY

# for ONE BUCK

YESSIR! A genuine, lever-action, hard-hitting DAISY for only ONE BUCK! And what a gun—31 inches of the sweetest working single-shot you ever laid your hands on.

For a long time Daisy gunsmiths have been working to perfect a real air rifle that could be sold for as little as \$1.00. The job was a tough one naturally, because, when finished, THIS air rifle had to measure up to ALL of Daisy's high standards of quality.

The new, improved No. 101 is the answer. It's made of the same heavy, tough, blued gun steel that goes into the higher priced Daisys, and the stock is made of selected hardwood, walnut finished. And just to make sure it would "stand the gaff"—continue to deliver one bullseye after another—we SEALED IN THE SHOOTING BARREL! Make no mistake—it's PERMANENTLY FIXED in position—RIGID and trouble-free!



## BUCK JONES

*Round Up*

WATCH FOR BUCK JONES FEATURE PICTURES AND SERIALS AT YOUR LOCAL THEATRE

### AIR UNDER CONTROL



AIR BRAKES CAN STOP THOUSANDS OF TONS OF ROARING FREIGHT TRAIN, ALMOST INSTANTLY—THAT'S "AIR UNDER CONTROL" AND THAT'S WHAT MAKES YOUR DAISY A POWERFUL AND AN ACCURATE SHOOTER.

### BUILT RIGHT!



THAT SWELL LITTLE #101 DAISY HAS TO PASS THROUGH 37 DIFFERENT PAIRS OF HANDS BEFORE IT IS READY TO LEAVE THE DAISY PLANT, BEARING THE DAISY NAME OF QUALITY.

### ALL AMERICAN



EVERY DAISY WORKMAN IS A 100% AMERICAN

CITIZEN AND EVERY PIECE OF MATERIAL FOR YOUR DAISY IS PRODUCED IN THE U.S.A.!

### COUPON

DAISY MANUFACTURING CO.,  
330 Union St., Plymouth, Michigan

Here's my buck. Rush that new DAISY No. 101 Single-Shot along—and a sample of that famous Bulls Eye Shot.

Name \_\_\_\_\_

Street & No. \_\_\_\_\_

City & State \_\_\_\_\_

### HERE'S YOUR BIG CHANCE

You've wanted a Daisy for a long time—well, THIS is your chance to get one—and for ONLY one buck! Don't let the low price fool you—this newest Daisy Single-Shot is nothing cheap! It's ALL air rifle—and worthy of the name DAISY. See it at your Daisy dealer's TODAY. (If he happens to be out of the new No. 101, just clip a dollar bill to the coupon attached to this ad. Mail it to us and we'll send this Daisy, together with a generous trial sample of Bulls Eye Shot, postpaid by return mail. Don't delay another minute—get YOUR Daisy NOW!)

DAISY MANUFACTURING CO. - 330 UNION ST. - PLYMOUTH, MICHIGAN

# DAISY AIR RIFLES



WE DO OUR PART

